

# STATE OF FLORIDA



## EROSION AND SEDIMENT CONTROL

DESIGNER AND REVIEWER MANUAL

Official Release and Effective: June 2007

**Latest Update: July 2013**

Prepared for:

**FLORIDA DEPARTMENT OF TRANSPORTATION**

&

**FLORIDA DEPARTMENT OF ENVIRONMENTAL PROTECTION**

Tallahassee, FL

Prepared by:

**State Erosion and Sediment Control Task Force**

In cooperation with:

**HydroDynamics Incorporated**

Parker, CO

And

**Stormwater Management Academy**

University of Central Florida

Orlando, FL

**This page intentionally left blank**

## **Table of Contents**

### **SECTION I: GENERAL INFORMATION**

#### **INTRODUCTION**

PURPOSE OF THE MANUAL

THREE BASIC DEFINITIONS

SEDIMENT LOADING

*Impact to Water Bodies*

*Nutrients, Pesticides, and Heavy Metals*

*Hydrocarbons and Other Wastes Found in Runoff Waters*

*The Importance of Vegetation*

*Identifying the Sources*

### **REGULATIONS AND STATUTORY REQUIREMENTS**

CONSTRUCTION ACTIVITIES

IDENTIFICATION OF OPERATORS

CGP REQUIREMENTS

*Understand the CGP and Develop a SWPPP*

*Complete an NOI Application*

*Inspections*

*Notice of Termination (NOT)*

*Retention of Records*

*General Comments*

### **SECTION II: DEVELOPING EFFECTIVE SWPPP'S AND E&SC DRAWINGS**

#### **CONTENTS OF A SWPPP**

NARRATIVE REPORT

*Designer Certification Requirement*

*Contractor Certification Requirement*

CALCULATIONS

EROSION AND SEDIMENT CONTROL DRAWINGS

RECORD REQUIREMENTS

*SWPPP and E&SC Drawing Update Requirements*

#### **DEVELOPING EFFECTIVE E&SC DRAWINGS**

THE IMPORTANCE OF PERTINENT DATA

*Collecting Data*

*Interpreting and Evaluating Data*

DEVELOPING EFFECTIVE E&SC DRAWINGS

*Title Sheet*

*Pre Grading Drawings*

*During Grading Drawings*

*After Grading Drawings*

*Typical Detail and Specification Sheets*

*Miscellaneous Comments*

*E&SC Drawing Summary*

**SECTION III: EROSION CONTROL METHODS**

**INTRODUCTION**

**USE OF VEGETATION**

MAINTAINING ESTABLISHED VEGETATION

VEGETATIVE FILTER STRIPS

ESTABLISHING VEGETATION

*Sod*

*Permanent Vegetation*

*Temporary Vegetation*

*Planting Seed*

*Pure Live Seed Rates vs. Bulk Rates*

*Methods of Planting Seed*

*Polymer Enhanced Soil Stabilization*

MULCHES

*Dry Mulches*

*Compost Materials*

*Hydraulic Mulches*

SOIL BINDERS

**ROLLED EROSION CONTROL PRODUCTS (RECP'S)**

RECPs FOR DISTURBED SLOPES

SOFT ARMORING RECPs FOR CONCENTRATED FLOWS

*Small Drainage Channels RECPs*

*Selecting a RECP for Small Drainage Channels*

**RUNOFF CONTROL STRUCTURES**

DIVERSION DIKES AND CONVEYANCE CHANNELS

BASIN SLOPE DRAINS

ROADWAY SLOPE DRAINS

CHANNEL CHECK STRUCTURES

*Spacing of Check Structures*

**EXAMPLES**

CHANNEL RECP FOR A SPECIFIC FLOW

BASIN SLOPE DRAIN

ROADWAY SLOPE DRAIN

**SECTION IV: SEDIMENT CONTAINMENT SYSTEMS (SCS'S)**

**INTRODUCTION**

DESIGNING SCSs INTO AN E&SC DRAWING

DEFINING SEDIMENT CONTAINMENT SYSTEMS

EFFECTIVENESS OF SEDIMENT CONTAINMENT SYSTEMS

SEDIMENT CONTAINMENT SYSTEM OUTLET STRUCTURES

*Surface Skimmers*

*Perforated Riser Pipes*

**DEWATERING ACTIVITIES**

TYPES OF DEWATERING METHODS

*Rim Ditching*

*Sock Pipe/Horizontal Wells*

*Well Point Systems*

TURBIDITY MONITORING FOR OFF-SITE DISCHARGE

USING SCSs FOR DEWATERING

INCREASING THE EFFICIENCY OF A SCS

*Pre-Sedimentation Basins*

*Barriers for Pre-Sedimentation Basins*

USE OF POLYMERS OR ALUM

*Steps for Introducing Polymers into Runoff Waters*

*Sediment Retention Barriers Using Polymers*

*Runoff Water Sediment Removal using Alum*

**EXAMPLES**

SCS EFFECTIVENESS OF AN EXISTING POND

SIZING A DEWATERING SCS

BUILDER PRE-SEDIMENTATION BASIN

LINEAR ROAD PRE-SEDIMENTATION BASIN

## **SECTION V: TEMPORARY CONSTRUCTION SITE BMPS**

### **INTRODUCTION**

#### **USING BARRIERS TO REMOVE SEDIMENT FROM RUNOFF WATERS**

LIMITATION OF BALE BARRIERS

SILT-FENCE BARRIERS

FIBER LOGS

TEMPORARY COMPOST BERMS

DITCH BOTTOM INLET (CATCH BASIN) BARRIERS

BARRIERS FOR STORM SEWER CURB INLET OPENINGS

*Curb and Gutter Sediment Containment System*

*Inlet Inserts*

*Cellular Confinement Systems*

USING POLYMERS TO INCREASE SEDIMENT REMOVAL FROM RUNOFF WATERS

USING BMPS WHEN BUILDING BOX CULVERTS

### **APPENDIX I**

COASTAL APPLICATIONS

### **APPENDIX II**

DEWATERING

### **APPENDIX III**

POLYMERS AND ALUM

### **APPENDIX IV**

INSPECTION FORMS

SCHEDULING FORMS

### **APPENDIX V**

VERTICAL/BIG BOX E&SC PLAN

HIGHWAY E&SC PLAN

TYPICAL DETAILS

## **Acknowledgments**

**Development of this manual was funded by the Florida Department of Transportation and the Florida Department of Environmental Protection.**

**With Special Thanks to the Manual Advisory Committee**

**Fernando Ascanio, FDOT  
Josh Boan, FDOT  
Manoj Chopra, UCF  
Susan Davis, SJRWMD  
Cammie Dewey, SJRWMD  
Jerry Fifield, HDI  
Carol Griggs, SJRWMD  
Steve Iwinski, APS  
Eric Livingston, FDEP  
Paul O'Neil, SWFWMD  
Rick Renna, FDOT  
Andi Reyes, SFWMD  
Heather Ritchie, FDEP  
Larry Ritchie, FDOT  
David Sadler, FDOT  
Jenny Sargent, FDOT  
Jim Smoot, USGS  
Marty Wanielista, UCF  
Ben Watson, FDOT  
Molly Wood, USGS  
Ed Yaun, SFWMD**

**This manual was edited by Ryan Browne, UCF and approved for publication.**

**© June 2007**

**© July 2013**





**This page intentionally left blank**

**SECTION I**  
**GENERAL INFORMATION**

## TABLE OF CONTENTS

<b>INTRODUCTION .....</b>	<b>1</b>
PURPOSE OF THE MANUAL .....	1
THREE BASIC DEFINITIONS .....	2
SEDIMENT LOADING .....	3
<i>Impact to Water Bodies</i> .....	3
<i>Nutrients, Pesticides, and Heavy Metals</i> .....	3
<i>Hydrocarbons and Other Wastes Found in Runoff Waters</i> .....	3
<i>The Importance of Vegetation</i> .....	4
<i>Identifying the Sources</i> .....	4
<b>REGULATIONS AND STATUTORY REQUIREMENTS .....</b>	<b>4</b>
CONSTRUCTION ACTIVITIES .....	5
IDENTIFICATION OF OPERATORS .....	6
CGP REQUIREMENTS .....	6
<i>Understand the CGP and Develop a SWPPP</i> .....	6
<i>Complete an NOI Application</i> .....	6
<i>Inspections</i> .....	7
<i>Notice of Termination</i> .....	7
<i>Retention of Records</i> .....	8
<i>General Comments</i> .....	8

## **INTRODUCTION**

With the adoption of the statewide stormwater rule in 1982, Florida was the first state in the country to require the treatment of stormwater from all new development. The stormwater rule is a technology-based rule relying upon a performance standard (environmental goal) and Best Management Practices (BMPs) design criteria that are presumed to meet the goal. The performance standards are set forth in the Water Resource Implementation Rule (Chapter 62-40, F.A.C.).

Performance standards for erosion and sediment control during grading is to retain sediment on-site, with a backstop that no discharge shall violate the State of Florida's water quality standard for turbidity. Thus, goals of Florida's stormwater regulatory program and the Florida Department of Environmental Protection (FDEP) are to protect water quality and to minimize erosion and sedimentation by requiring the use of effective BMPs during and after grading.

Additionally, as mandated by the Clean Water Act (CWA), permits must be obtained for stormwater discharges from construction sites that meet or exceed the Environmental Protection Agency (EPA)'s criteria (see <http://www.epa.gov/region5/water/cwa.htm>). The EPA has the responsibility of administering CWA requirements by requiring National Pollutant Discharge Elimination System (NPDES) discharge permits. FDEP implements the NPDES program in Florida and to issue Florida NPDES discharge permits. By reviewing <http://www.dep.state.fl.us/water/stormwater/npdes/index.htm>, readers of this manual can obtain more detailed information on Florida statutory requirements and FDEP programs and requirements.

### ***Purpose of the Manual***

This manual will assist designers and reviewers in providing meaningful and practical Erosion and Sediment Control (E&SC) drawings as part of the Stormwater Pollution Prevention Plan (SWPPP) for the contractor to implement. Preparation and review of SWPPP and E&SC drawings need to be done by, or under the supervision of, professionals having demonstrative erosion and sediment control experience and skills necessary for development and review of effective and practical documents. These individuals are identified throughout this manual as Designers. It is important to note that additional qualifications may be required by governmental agencies, such as having construction field experience, supplementary training and education, passing an examination, and so forth.

This manual has been developed to strive toward a consistent level of technical expertise and professional conduct for designers and reviewers developing and reviewing E&SC drawings and SWPPP. These are required not only to meet NPDES stormwater requirements but are also an integral part of the stormwater management plan that must be approved by FDEP or the Water Management Districts (WMDs) to obtain a Florida stormwater or Environmental Resource Permit (ERP). Ultimately, the guidance in this manual strives to ensure the desired benefits of stormwater management systems are being achieved.

### ***Three Basic Definitions***

Natural erosion occurs at a relatively slow rate; however, accelerated erosion is primarily caused by the removal of natural vegetation or alteration of the ground contour by land disturbing and construction activities. The nature of construction activities will result in increased erosion rates, transportation of sediment by runoff, and create problems associated with sedimentation. The purpose of this manual is to present methods that Designers can use and reviewers will recognize to reduce sediment in runoff waters and minimize the erosion process on sites where construction activity is occurring. It is important that Designers and reviewers understand the following three basic definitions:

- Erosion: The process by which rainfall, wind and water dislodges soil particles.
  - *Splash erosion* is the dislodging of soil particles by raindrop impacts, resulting in the dispersal and mobilization of the soil particles.
  - *Sheet flow erosion* is the uniform removal of saturated soil particles conveyed in runoff waters.
  - *Rill erosion* is a long, narrow depression or soil incision caused by increased topographic relief and higher runoff velocities. They are the result of concentrated flows that result in vertical (meaning, incising into the ground) and sheet flow erosion.
  - *Gully erosion* is the deep and wide depression caused by concentrated flows.
  - *Stream bank erosion* is the removal of soil by a natural drainage pattern, such as toe cutting and bank sloughing.
  - *Shoreline erosion* is the removal of soil by high-energy wave action, resulting in sloughing and mass wasting.
- Sediment: Soil particles suspended in, or moved by, stormwater runoff.
- Sedimentation: The deposition of sediment.

Some of the factors influencing erosion include soil characteristics, existing vegetative cover, topography and climate. Soil properties which influence erosion by rainfall and stormwater runoff are those which affect the infiltration capacity of a soil and those which affect the resistance of the soil to detachment and transport by flowing or falling water. Vegetative cover plays an extremely important role in reducing erosion and can be controlled during land disturbing activities.

Sequentially scheduling and limiting the removal of vegetation and decreasing the area and duration of exposure can significantly reduce soil erosion and sedimentation. Topographic characteristics of the watershed can influence the amount and rate of stormwater runoff since slope length and gradient directly influence the volume and velocity of runoff and erosion risks. Climate, especially rainfall frequency, intensity and duration are fundamental factors in determining the amount of runoff. As volume and velocity increase, the capacity of runoff to detach and transport soil particles also increases.

This manual will provide guidelines for developing and reviewing effective E&SC drawings that incorporate methods for removing sediment from runoff waters and minimize erosion in a cost effective and practical manner that protects the environment while construction activities occur.

Designers must confer with the appropriate Water Management District (WMD), as well as the Florida Department of Transportation (FDOT) office when completing projects within their jurisdiction to ensure that they address all necessary environmental concerns.

### ***Sediment Loading***

#### Impact to Water Bodies

When Total Suspended Solids (TSS) occur in large quantities, degraded water quality can be harmful to plants and animals and interfere with such life functions as photosynthesis, respiration, growth, and reproduction. Since construction projects can be one source of soil particles that fill Florida's streams, lakes, canals, and shorelines, it is important to understand how to control sediment both during and following land disturbance activities.

As construction activities disturb land, erosion occurs during rainfall or wind events. Once suspended in water, soil particles may become a major water pollutant. For example, sediment loading causes the following:

- Construction areas can produce 10 to 20 times more than soil particles lost from lands where vegetation exists.
- Reservoirs, harbors, and canals to clog with silt.
- Loss of recreational areas and wildlife habitat.
- Reduces the beneficial uses of water for humans and can harm plants, animals, and aquatic life.

#### Nutrients, Pesticides, and Heavy Metals

Sediment loading from construction areas may also increase the amount of nutrients in water. Nutrients (especially phosphorus and nitrates) may come from fertilizers used at construction sites to aid in the establishment of vegetation. When runoff waters carry sediment downstream into water, plants that live in water use the nutrients to increase the biomass, which robs the water of oxygen, which kills aquatic organisms, including fish.

In addition to nutrients, herbicides and pesticides may also exist in construction site soils. When runoff events occur, these harmful chemicals are also carried with the sediments. In addition, improper application of pesticides can also result in the direct contamination of water.

It is estimated that over half of the trace metals carried in runoff waters are attached to sediments (Caltrans, 1996). Sources of these metals found at construction sites include galvanized metal, paint, and preserved wood. Nearly all metals can be toxic to plants, animals, and fish. In addition, metals can accumulate in the tissues of plants, animals, and fish and have the potential to contaminate drinking water.

#### Hydrocarbons and Other Wastes Found in Runoff Waters

Other pollutants found in runoff from construction sites include hydrocarbon compounds caused by leaks from heavy equipment, hydraulic line failures, hydrocarbon spills during refueling, inappropriate disposal of drained fluids, and so forth. When runoff occurs, these hydrocarbons can wash into the water, harming plant and animal life.

Other wastes from construction sites that can lead to unsightly and polluted water include:

- Wash water from concrete mixers

- Paints and painting equipment
- Wastes from cleaning of vehicles and equipment
- Wastes from trees and shrubs removed during land clearing
- Wood and paper from building product packaging
- Food containers, such as paper, aluminum, and metal cans
- Sanitary wastes

#### The Importance of Vegetation

The best method for minimizing the discharge of sediment from a construction site is to keep a good vegetative cover on the soil. When sufficient plant cover exists, raindrops or runoff waters can only cause minimal erosion of the soil. An extensive root system will also bind soil together to resist erosion by flowing water.

#### Identifying the Sources

Construction activities will result in the disturbance of existing plants, soil, and rocks. Problems often occur when soil is stockpiled, used to fill holes or low areas, or removed from the area. Other problems might occur from careless handling of construction materials or fuels on-site, since nutrients, trace metals, and hydrocarbons can seep into the ground from these sources. In addition, when storm events occur runoff may carry contaminated soils away from the construction site to become a source of downstream pollution. Less erosion means less sediment in runoff waters. Therefore, good erosion control means good sediment control. Reducing the amount of sediment in runoff water means there will be fewer pollutants carried downstream from their source.

Wetlands and fish habitats might require considerable time to recover following construction projects. To allow for recovery, activities should include establishing vegetation on disturbed areas to reduce the sediment entering downstream waters during and after grading activities occur. Care should also be taken to avoid excessive application of chemicals that could find their way into runoff from the site. Once the flow of sediment and pollutants is reduced, spawning beds can recover and the danger of fish suffocation is reduced.

### **REGULATIONS AND STATUTORY REQUIREMENTS**

On average, Florida receives 40- to 60-inches of rain each year, often in the form of torrential downpours that cause runoff carrying sediment, fertilizers, pesticides, oil, heavy metals, bacteria, and other contaminants which enter our surface waters. To minimize these adverse impacts, a Florida Stormwater or Environmental Resource Permit (ERP) must be obtained from the applicable WMD or FDEP office before construction begins. ERPs integrate stormwater quantity and quality, as well as wetland protection requirements into a single permit. They regulate activities such as dredging and filling-in wetlands, construction of stormwater facilities, stormwater treatment systems, construction of dams or reservoirs, and other activities affecting state waters. Each WMD has an operating agreement with FDEP about which agency will process ERPs for particular projects, based on the type of land use.

Specific requirements for stormwater management, including erosion and sediment control during grading, flood control, and stormwater treatment can be found in the specific ERP regulations applicable within the appropriate WMD. These requirements include specific design

criteria for various types of stormwater treatment practices. For additional details about these regulations, refer to <http://www.dep.state.fl.us/water/wetlands/erp/index.htm> or <http://flwaterpermits.com>.

In December 2000, the EPA authorized FDEP to implement the National Pollutant Discharge Elimination System (NPDES) Stormwater Program within the State of Florida, with the exception of Indian Nation lands. Mandated by the United States Congress under the Clean Water Act, the NPDES Stormwater Program is a national program for addressing many urban stormwater discharges, which may adversely impact water quality.

The NPDES Stormwater Program is completely separate from the State's stormwater/environmental resource permitting programs found under Part IV, Chapter 373 of the Florida Statutes. The NPDES Stormwater Program does not establish additional regulations for the construction/design features for retention areas, detention ponds, swales and other stormwater management systems. Additionally, the permit required under FDEP's NPDES Stormwater permitting program is also separate from any local government's stormwater discharge permit for construction activity.

The sources of stormwater discharges regulated under the NPDES Stormwater Program include the following three categories:

- Construction Activities
- Industrial Activities
- Municipal Separate Storm Sewer Systems

This section will only address construction activities. Florida's WMDs may have more stringent criteria than what is being presented in this manual and should be consulted for their requirements.

### ***Construction Activities***

Stormwater runoff from construction activities can have a significant impact on water quality by contributing sediment and other pollutants to water bodies. The NPDES Stormwater Program regulates construction activities that disturb one or more acres of land and discharge stormwater to surface waters of the State or into a municipal separate storm sewer system (MS4).

***The regulatory definition of a MS4 is "a conveyance or system of conveyances like roads with stormwater systems, municipal streets, catch basins, curbs, gutters, ditches, constructed channels, or storm drains."***

If a project is less than one acre, but part of a larger common plan of development or sale that will ultimately disturb one or more acres, permit coverage is also required. A larger common plan or development or sale is a contiguous area where multiple separate and distinct construction activities may be taking place at different times on different schedules. An example of this condition is the development of a housing subdivision.

When a developer buys a 20-acre parcel and builds roads, installs water/sewer with the intention of constructing homes or other structures in the future, this would be considered a larger



common plan or development or sale. If the land is parceled off or sold, and construction occurs on plots that are less than one acre by separate, independent builders, this activity still would be subject to NPDES stormwater permitting requirements regardless of the size of any of the individually owned lots.

### ***Identification of Operators***

The Generic Permit for Stormwater Discharge from Large and Small Construction Activities (CGP), (FDEP Document 62-621.300(4)(a), effective May 2003) defines “operator” as:

***“The person, firm, contractor, public organization, or other legal entity that owns or operates the construction activity and that has authority to control those activities at the project to ensure compliance with the terms and conditions of this permit.”***

The operator is ultimately responsible for obtaining permit coverage and implementing appropriate pollution prevention techniques to minimize erosion and sedimentation from stormwater discharges during grading.

For construction projects where the operator changes, the new operator should obtain permit coverage at least two (2) days before assuming control of the project. The previous operator should file a NPDES Stormwater Notice of Termination (FDEP Form 62-621.300(6)) to terminate coverage under the CGP. The previous operator must meet the conditions to terminate coverage in accordance with Part VIII of the CGP.

### ***CGP Requirements***

The following is a brief summary of major CGP requirements. For a complete summary of the regulatory requirements always refer to the CGP.

- A copy of the NOI or the acknowledgement letter from the Notices Center confirming coverage under the CGP must be posted at the construction site in a prominent place for public viewing (such as alongside the building permit).
- Inspections
- Termination of Coverage
- Retention of Records

To obtain NPDES stormwater permit coverage, a regulated construction operator must complete the following steps:

#### Understand the CGP and Develop a SWPPP

- 1) Obtain and carefully read the CGP (The CGP is available online at: <http://www.dep.state.fl.us/water/stormwater/npdes/construction3.htm>)
- 2) Develop a site specific Stormwater Pollution Prevention Plan (SWPPP). See Section II of this manual for additional information on how to develop a SWPPP.

#### Complete an NOI Application

- 1) Complete in its entirety the application or Notice of Intent (NOI) form (FDEP Form 62-621.300(4)(b)).

- 2) Submit the NOI with the appropriate processing fee to the NPDES Stormwater Notices Center.
  - a. Rule 62-4.050(4) (d), Florida Administrative Code, requires the processing fee\*.  
*\*The fee is subject to change so check the Rule to determine the appropriate fee when applying. Chapter 62-4 is available online at:  
<http://www.dep.state.fl.us/legal/Rules/mainrulelist.htm> or <http://fac.dos.state.fl.us/>*
  - b. **Do not** send plans or a copy of your SWPPP when applying for permit coverage. Only the NOI and appropriate fee is required. If the project site is inspected, the regulatory agency or designated representative will review the contents of the SWPPP at the time of the inspection. *(The regulatory agency may also at any time request that the SWPPP be submitted for review.)*
  - c. For projects that discharge stormwater to a MS4, a copy of the NOI must also be submitted to the operator of the MS4.

Operators seeking coverage under the CGP must apply for permit coverage at least two (2) days prior to the commencement of construction. Permit coverage under the CGP is effective two (2) days after the date of submittal of a complete NOI and appropriate fee. Submittal is interpreted as “postmarked.” All NOIs should be mailed to:

Florida Department of Environmental Protection  
NPDES Stormwater Notices Center, MS#2510  
Tallahassee, FL 32399

The NPDES Stormwater Notices Center will send an acknowledgement letter to the operator after reviewing and processing your complete NOI and fee. The acknowledgment or confirmation letter identifies the permit or project number for your activity and indicates the issuance and expiration date for the CGP. Permit coverage under the CGP is limited to a term of five (5) years. If construction activity extends beyond a period of five (5) years, the operator will be required to reapply for permit coverage.

### Inspections

One of the key components of the CGP is the requirement for a qualified inspector to inspect all discharge points, disturbed areas, material storage areas, structural controls and construction entrances/exits at least once every seven (7) days and after every 0.50-inch or greater storm event. Major observations and incidents of non-compliance should be recorded in the inspection report, as well as corrective actions and maintenance.

Unless advised otherwise, maintenance must occur within seven (7) calendar days of the inspection. These inspections must be documented and signed by a qualified inspector as defined by the CGP. The report shall contain a certification that the facility is in compliance with the SWPPP and the CGP when the reports do not identify any incidents of non-compliance.

### Notice of Termination (NOT)

Upon completion of the project and final stabilization, the permittee needs to submit a signed NOT application to the NPDES Stormwater Notices Center and the MS4. Final stabilization is defined within the CGP as:

*“All soil disturbing activities at the site have been completed, and that a uniform perennial vegetative cover with a density of at least 70% for all unpaved areas*

*and areas not covered by permanent structures has been established or equivalent permanent stabilization measures have been employed.”*

When the operator changes to relinquish control of a project to a new operator, A NOT also shall be filed at:

NPDES Stormwater Section  
Florida Department of Environmental Protection  
NPDES - [stormwater@dep.state.fl.us](mailto:stormwater@dep.state.fl.us)  
[www.dep.state.fl.us/water/stormwater/npdes/](http://www.dep.state.fl.us/water/stormwater/npdes/)

### Retention of Records

The permittee needs to retain copies of the NOI, SWPPP, inspection reports, NOT, and any other supporting documentation for at least three (3) years from the date the site is finally stabilized.

### General Comments

It is important to note that the permit required under FDEP’s NPDES Stormwater permitting program is separate from the Environmental Resource Permit (ERP) required under Part IV, Chapter 373, F.S., a stormwater discharge permit required under Chapter 62-25, FAC, or any local government’s stormwater discharge permit for construction activity.

The FDEP/WMD Environmental Resource Permitting Program benefits Florida by requiring the implementation of effective mitigation measures that will minimize stormwater pollution to Florida's lakes and streams and protect wetlands (see <http://www.flwaterpermits.com>).

Designers need to identify within which of the five WMDs (seen at right) that their project is located to ensure all permits and environmental issues are properly addressed within their SWPPP. Also, it will be necessary to contact the appropriate WMD office for specific ERP and dewatering permit requirements.

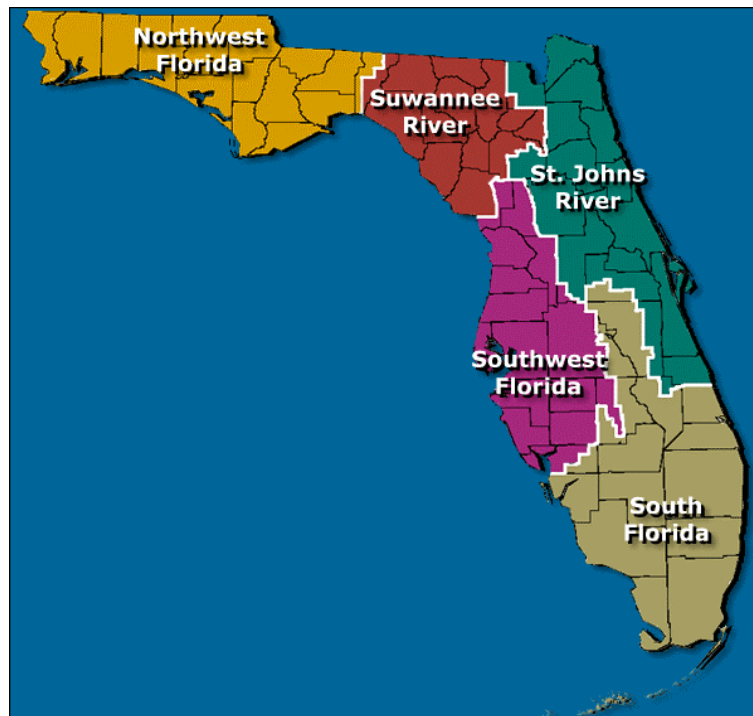

**SECTION II**  
**DEVELOPING EFFECTIVE SWPPP'S AND E&SC DRAWINGS**

## Table of Contents

<b>CONTENTS OF A SWPPP .....</b>	<b>1</b>
NARRATIVE REPORT .....	1
<i>Designer Certification Requirement</i> .....	2
<i>Contractor Certification Requirement</i> .....	2
CALCULATIONS.....	3
EROSION AND SEDIMENT CONTROL DRAWINGS.....	3
RECORD REQUIREMENTS .....	5
<i>SWPPP and E&amp;SC Drawing Update Requirements</i> .....	6
<b>DEVELOPING EFFECTIVE E&amp;SC DRAWINGS .....</b>	<b>6</b>
THE IMPORTANCE OF PERTINENT DATA.....	7
<i>Collecting Data</i> .....	7
<i>Interpreting and Evaluating Data</i> .....	7
DEVELOPING EFFECTIVE E&SC DRAWINGS .....	8
<i>Title Sheet</i> .....	8
<i>Pre Grading Drawings</i> .....	9
<i>During Grading Drawings</i> .....	10
<i>After Grading Drawings</i> .....	11
<i>Typical Detail and Specification Sheets</i> .....	12
<i>Miscellaneous Comments</i> .....	12
<i>E&amp;SC Drawing Summary</i> .....	12

## **CONTENTS OF A SWPPP**

The Stormwater Pollution Prevention Plan and accompanying E&SC plans shall identify potential sources of pollution that may reasonably be expected to affect the quality of stormwater discharge associated with construction activity. In addition, the plan shall describe and ensure the implementation of BMPs, which will be used to reduce the pollutants in stormwater discharge associated with construction activity and to assure compliance with the terms and conditions of the permit. A thorough understanding of the plan is essential for proper implementation and maintenance.

The SWPPP must be developed before an NOI is filed to receive the Generic Permit for Stormwater Discharge from Large and Small Construction Activities (CGP) coverage and meet or exceed FDEP requirements. Also, beginning on the first day of construction activities, the SWPPP and E&SC drawings must be available at the location identified in the NOI (see <http://www.dep.state.fl.us>)

A copy of the NOI or Notice of Coverage from FDEP shall be posted at the construction site in a prominent place for viewing. The location of the SWPPP is identified in the NOI and may or may not necessarily be at the construction site.

A SWPPP will consist of a narrative (including any calculations), E&SC drawings, and record requirements. In addition, the CGP requires a certification statement to be signed by the operator. It is strongly recommended that the Designer also sign a certification to ensure accountability exists. The SWPPP shall be developed and implemented for each construction site covered by this permit and be prepared in accordance with good engineering and scientific practices.

### ***Narrative Report***

The narrative report provides general information on what is to be completed to ensure minimal environmental damage as a construction project is developed. It should briefly describe the overall strategy for erosion and sediment control, as well as summarize the aspects of the project that are important for erosion control on-site for the plan reviewer and project superintendent.

A site description shall be included in the narrative report and include at a minimum the following information about the site:

- Description of the construction activity
- Total area of the site and total disturbance area
- Intended sequence of land disturbing activities
- Description of the soils and an identification of those that are highly erodible
- Drainage area for each major discharge point
- Latitude and longitude of each major discharge point
- Names of receiving water(s)
- Description of proposed pollution control measures (i.e. BMPs) to be used
- General sequence during the construction process in which the measures will be installed
- Estimated start date, completion date and stabilization schedule

- If possible, an identification of the contractor or subcontractor responsible for the BMP implementation, inspection, and maintenance

#### Operator (Permittee) Certification Requirement

Designers must sign, stamp (if appropriate), and date the following certification statement as part of their SWPPP:

*“I certify under penalty of law that this document and all attachments were prepared under my direction or supervision in accordance with a system designed to assure that qualified personnel properly gathered and evaluated the information submitted. Based on my inquiry of the person or persons who manage the system, or those persons directly responsible for gathering the information, the information submitted is, to the best of my knowledge and belief, true, accurate, and complete. I am aware that there are significant penalties for submitting false information, including the possibility of fine and imprisonment for knowing violations.”*

#### Contractor Certification Requirement

All contractors and subcontractors identified in the SWPPP, or those selected at a later date, must sign and date the following certification statement before conducting land-disturbing activities on the site:

*“I certify under penalty of law that I understand, and shall comply with, the terms and conditions of the State of Florida Generic Permit for Stormwater Discharge from Large and Small Construction Activities and this Stormwater Pollution Prevention Plan prepared there under.”*

Inspection and maintenance of structural (e.g. sediment control) and non-structural (e.g. erosion control) BMPs are important aspects of the CGP and must be addressed in the SWPPP. The narrative report should briefly describe procedures that will be followed to ensure the timely installation, inspection, and maintenance of existing vegetation, erosion and sediment controls, stormwater management practices, and other protective measures so they will remain in effective operating condition.

All points of discharge into any surface waters (including wetlands), disturbed areas, material storage areas, structural controls, and vehicle ingress/egress areas must be inspected and documented at least once a week and after each storm event of 0.50-inches or greater. Unless advised otherwise, deficiencies will be corrected within seven (7) calendar days after being noted in the inspection report.

The CGP also requires that other potential pollutants be addressed in the SWPPP. Some of the items to consider may include paints, herbicides, pesticides, fertilizers, fuel, construction debris, chemicals, litter, and sanitary waste. The SWPPP will need to identify the storage areas, means of minimizing exposure to stormwater, proper disposal, as well as spill prevention and response measures.

The permit does not authorize the discharge of solid materials to surface waters of the State or an MS4; however, some non-stormwater discharges are allowable under the CGP if they meet conditions outlined in the CGP.

### ***Calculations***

This section of the SWPPP (usually an appendix) will contain information and calculations used in completing the design and illustration of BMPs found in the E&SC drawing. Examples include (but are not limited to) the following:

- Sizing of sediment containment systems (SCSs)
- Sizing of slope drains
- Shear stress and velocity values for drainage channel Rolled Erosion Control Products (RECPs)
- Seed mixture and application rates
- Application rates of soil amendments, herbicides, pesticides and fertilizers
- Flood flow evaluations at critical design points

### ***Erosion and Sediment Control Drawings***

The site plan or E&SC drawing is a key component of the SWPPP and must be developed for the contractor in a manner that meets federal, state and local environmental concerns. It has been found that contractors implement components of E&SC drawings more effectively when definitive legend symbols, informative leader notes, and meaningful shading appear throughout the drawings. While use of standard symbols denoting erosion and sediment control BMP measures are acceptable, they can be confusing to contractors if not used prudently and conservatively.

At a minimum, E&SC drawings will depict the following:

- Pre- and post-development drainage patterns
- Critical areas (e.g. highly erodible soils, wetlands, major discharge points, etc.)
- Structural and nonstructural controls
- Locations where offsite flows enter the site
- Discharge locations
- Existing vegetation and limits of clearing
- Erosion and sediment control measures (include proposed sediment basins) and proposed locations
- Proposed post-construction stormwater management measures
- Off-site soil tracking prevention devices

Land disturbance contractors have the task of “molding” existing terrain into a final product for their client. At the same time, they have to complete their construction activities in a manner that meets FDEP, EPA, and other regulatory agency requirements for protecting waters of the United States. Therefore, it is recommended that Designers include the following when developing E&SC drawings:

- A Title Sheet that provides general information about the site including a general location map with sufficient detail to identify the construction site location and waters of the United States within one mile of the site. Also included should be a preliminary schedule for implementation of sediment and erosion control BMPs.



- Pre Grading drawings that illustrate existing site conditions and identify major discharge points, names of the receiving water(s) for each point, and show where to install structural (i.e. sediment control) measures before construction activities begin.
- During Grading drawings that illustrate what happens while land modifications activities occur. These sets of drawings evolve from project grading plans and must demonstrate the implementation of structural (i.e. sediment control) methods while major grading activities occur. In addition, references to non-structural (i.e. erosion control) BMPs found on After Grading drawings are to occur.
- After Grading drawings that illustrate the implementation of sediment and erosion control measures after grading activities are completed. It is on this set of plans where non-structural measures are depicted that are to be implemented while construction activities occur.
- Typical Detail and Specification drawings that provide the contractor with visual concepts of what is to be installed to reduce sediment from leaving a construction site as well as the type of erosion control methods that are to be used.

Designers may find that combining Pre- and During Grading drawings is feasible and may be acceptable to regulatory agencies. *However, except perhaps for very small projects, combining all three construction plans into a single drawing is discouraged because of legibility.*

Construction details, often in large-scale drawings, provide key dimensions and spatial information that will not fit on the E&SC drawing or site map. Other important information also should be provided such as specifications for planting seed, mulching, sediment barriers, erosion control materials, installation procedures, inspection requirements, and maintenance instructions. Detailed information and explanation about construction site BMPs can also be found in FDEP's manual at [http://www.dep.state.fl.us/water/nonpoint/ero\\_man.htm](http://www.dep.state.fl.us/water/nonpoint/ero_man.htm).

In addition to the above, designers will include within the E&SC drawings, guidelines for development of concrete washout areas and how storage of hazardous waste materials will occur. Criteria for concrete washout areas may include (but is not limited to) the following items:

- Shallow excavations lined with a material to prevent infiltration of washout material
- A soil tracking prevention device (see Section V) at the access point
- Signs throughout the construction site identifying the location
- Development of a containment structure
- Maintenance and termination plan

Designers should be innovative and consider other alternatives such as portable containment units, using washout material as part of driveways, and so forth.

Criteria for storage of hazardous waste material (e.g. petroleum products, pesticides, or paints, etc.) are more stringent and may include (but not be limited to) the following items:

- Development of temporary containment facilities that are away from water bodies and include sufficient spill containment areas and impervious surfaces
- Maintenance of temporary containment facilities against rainfall and spills
- Proper drum storage
- Location of where cleaning of paint related equipment is to occur

- Refueling stations
- Labeling waste containers
- Disposal procedures
- Procedures for reporting spills

For those having expertise on sediment and erosion control methods, this Designer manual provides summary information and illustrations of BMPs commonly found on land development, linear, and vertical/big box construction sites. As a summary, the remaining sections of this manual include the following:

- Section III provides information and drawings about erosion control methods and includes the following topics:
  - √ Runoff control structures such as diversion dikes, slope drains, and channel check structures
  - √ Vegetation topics such as staging, filter strips, and seeding requirements
  - √ Importance of mulches, soil binders
  - √ Selecting and installing RECPs on hillsides and in drainage channels
- Section IV discusses what is needed for the design of SCSs (a.k.a. sediment ponds, basins, and traps) and includes:
  - √ Criteria for containment of design size suspended particles
  - √ How to increase the efficiency of SCSs
  - √ Criteria for development of pre-sedimentation (a.k.a. forebay) basins
- Section V presents information on, and limitations of, commonly found sediment control BMPs that remove limited amounts of sediment from runoff waters. Specific topics include:
  - √ Uses of silt fence barriers
  - √ Information on using check structures and wattles
  - √ Methods for reducing sediment discharging into area (a.k.a. catch basin) drains
  - √ Methods for reducing sediment discharging into curb inlet drains

*Designers need to remember that they are developing E&SC drawings for contractors to implement.* In addition, reviewers, inspectors, and contractors must remember that E&SC drawings are only a “first appraisal” as to what is needed for reducing sediment in runoff waters and minimizing erosion. Consequently, Designers need to clearly indicate throughout the SWPPP and E&SC drawings, that these documents will require updating and modification while construction activities occur.

### ***Record Requirements***

The last part of a SWPPP involves keeping good inspection records. Record keeping is one of the most critical components of SWPPP requirements. Consequently, FDEP (and EPA) expects the contractor to complete the necessary record keeping tasks in a regular and expedient manner *while construction activities are occurring.*

1. Contractors must record the following dates:
  - a) When major grading activities occur
  - b) When construction activities temporarily or permanently cease on a portion of the site
  - c) When stabilization (i.e. erosion control) measures begin

2. Contractors are to provide qualified inspectors who have knowledge and experience in the principles and practice of sediment and erosion control and can complete project site inspections:
  - a) At least once every seven (7) days
  - b) Within 24 hours after the end of a storm event of 0.50-inches or more
3. Contractors are encouraged to provide a Designer responsible for evaluating and inspecting the construction site at least once every 30 days while activities are occurring. This individual will be responsible for developing and signing their inspection report upon completion of site visits.

Reports for each inspection are to be part of the SWPPP records while construction activities occur and are to include certification about compliance and non-compliance issues found. In addition, those that have signed the NOI application are to retain reports for at least three (3) years from the date permit coverage expires or terminates. Appendix IV contains suggested inspection forms.

#### SWPPP and E&SC Drawing Update Requirements

The SWPPP is a dynamic document containing a set of sediment and erosion control drawings that provide a first appraisal of where to install BMPs on construction sites. Consequently, Designers need to clearly indicate in the SWPPP and accompanying E&SC drawings that they must be revised within seven calendar days following an inspection when additions and/or modifications to BMPs are necessary to correct observed problems. Revisions should occur:

- Whenever a change in the design, construction, operation, or maintenance at the construction site has a significant effect on the discharge of pollutants to the waters of the United States not previously addressed in the document.
- Whenever discharges are causing water quality “exceedance” (an EPA term) or the BMPs are ineffective (to an extent practical) in minimizing pollutants in stormwater discharging from the construction site.

It is expected that the operator’s inspectors and Designers will work together to ensure updates occur in a timely manner.

### **DEVELOPING EFFECTIVE E&SC DRAWINGS**

There are many ways to develop E&SC drawings, all of which require Designers to address the following questions:

1. For **WHOM** is the plan being written?  
Drawings must be readable, practical, and easily understood for use by contractors.
2. **WHO** is going to develop the plans?  
Designers must have the skills and qualifications to understand what is required for effective sediment and erosion control.
3. **HOW** will the plan be implemented?  
Sufficient guidelines and illustrations must appear on the plans to ensure contractors doing land disturbance activities understand what BMPs to install, inspect, and maintain for Pre-, During, and After Grading conditions.

4. **WHEN** will the plan be implemented and inspected?

Plans must contain sufficient information to demonstrate when installation of BMPs should occur and provide guidelines for their inspection and maintenance.

5. **WHERE** will BMPs be installed?

All E&SC drawings must identify to contractors those approximate locations where installation of BMPs is to occur while land disturbance activities are occurring.

6. **WHY** are plans being developed?

Designers must understand that they are developing plans so that contractors will be able to protect the environment while construction activities occur. In addition, the E&SC drawings need to demonstrate competency to regulatory personnel reviewing the plans.

7. **WHAT** has been developed?

Designers, contractors, and regulatory personnel must understand that E&SC drawings only provide a conceptual illustration as to how to reduce sediment in runoff waters and minimize erosion. Changes to the E&SC drawings must occur during the construction process.

***The Importance of Pertinent Data***

Locating and reviewing data are essential for understanding what is required for effective control of sediment and erosion and developing an effective E&SC drawing. Consequently, Designers are expected to collect, interpret, and evaluate data about the construction site.

Collecting Data

Regulatory agencies expect that E&SC drawings reflect a Designer's expertise and professional skills by demonstrating that data collected includes at least the following items:

- Climate and rainfall data
- Soils data
- Existing and new vegetation requirements
- Location of critical areas
- Potential water quality problems and how they will be addressed
- Existing drainage channels
- Hydrologic characteristics of the site
- Topographical mapping

Interpreting and Evaluating Data

Development of effective E&SC drawings requires Designers to understand runoff flow patterns, soil erodibility, vegetation establishment requirements, and potential impacts to downstream properties. Thus, it is important that identification of the following hydrologic characteristics for contributing drainage basins occur:

1. Drainage divides within the construction site boundaries
2. Historic and developed flow patterns
3. Identification of offsite drainage conditions that may impact the project site
4. Major basin discharge points

5. Existing natural drainage ways

In addition to the above, it is suggested that volume and peak flood flows for 2-year, 24-hour storm events also be provided so that proper design of SCSs can occur.

Another essential part of an effective E&SC drawing is identifying “critical” areas, including (but not limited to):

1. Highly erodible lands within the project area
2. Wetlands and riparian areas
3. Threatened or endangered wildlife and plants
4. Known contaminated sites (e.g. fuel storage facilities, waste stations, etc.)
5. Historic sites
6. Fishery and spawning streams
7. Waters impaired by pollutants

Evaluating soils and existing vegetation must occur to develop historic data for comparison with final reclamation of the site. When possible, Designers need to assess the following parameters before construction activities begin:

- Topsoil and subsoil materials nutrient levels
- Location of highly erodible soils
- Existing vegetative species identification (e.g. grasses, forbs, shrubs, and trees)
- Vegetative re-establishment criteria

***Developing Effective E&SC Drawings***

Once construction site data and information is interpreted and evaluated, results must become part of practical and realistic plans. Readers of this manual are encouraged to review examples of E&SC drawings found in Appendix V for linear and vertical/box projects.

Title Sheet

As part of the sediment and erosion control drawings, a title sheet shall be prepared that illustrates at least the following general information about the construction site:

1. Project Name,
2. One quarter Section, Township, Range
3. Project location illustrated on a USGS quadrangle map (scale of 1” = 2,000’ or smaller)
4. Contractor commitments along with accompanying signature
5. Preliminary schedule of activities
6. Index to the sheets
7. Signed and stamped (if appropriate) by a designer who is acceptable to the reviewing agency

Located within Appendix IV is a template for developing a preliminary schedule of activities that Designers may find to be helpful. Contractors need to adhere to the intent of a preliminary schedule since it provides guidelines for regulatory agencies to complete their inspections.

### Pre Grading Drawings

Perhaps the most important set of drawings are those that clearly identify to contractors what to install *before* major construction activities begin. These “Pre Grading” drawings must illustrate what and where to initially install sediment control measures that ensure minimal runoff impacts to adjacent properties or water bodies when land disturbance activities begin. More than one drawing may be needed.

Pre Grading drawings shall contain detailed drawings using an adequate scale that clearly illustrate the project site as well as include a north arrow, legend, date, elevation datum, and so forth. In addition, each Pre Grading drawing shall include at least the following information:

1. Project boundaries.
2. Existing (do not include proposed) contours throughout, *and at least 50 feet outside the perimeter of*, the project site. Suggested contour intervals are 0.5- to 2-feet apart, but others may be necessary to ensure clarity of the plan.
3. Existing topographic features (streams, ponds, wetlands, roads, existing drainage channels, existing buildings, where offsite flows enter the property, and so forth) throughout, *and at least 50 feet outside the perimeter of*, the project site.
4. Existing types of vegetation throughout, *and at least 50 feet outside the perimeter of*, the project site.
5. Existing drainage basins and flow arrows illustrating runoff patterns within the project site.
6. Identifying different disturbance phases of the project site.
7. Location of sensitive areas and (if appropriate) existing problems within the project site.
8. Identifying approximate locations of where to install structural (i.e. sediment control) BMPs *before* construction activities begin. For some agencies, it may be necessary to illustrate “Owners Pay Item Structure” for the BMPs (see Appendix V).
9. Minimum requirements for inspection and maintenance of BMPs.

One of the important tasks to complete with pre grading drawings is for designers to identify where water flows through the project and where critical discharge points exist. It is at these locations that significant flows can enter a water body and carry sediment onto downstream locations. As indicated earlier, latitude and longitude values are necessary for critical discharge points. The next (i.e. during grading) drawings must illustrate how discharges at the critical discharge points are addressed.

Notice that the Pre grading drawings illustrate only existing land contours. By not combining existing and future contours, the contractor can properly assess the site for selecting and implementing sediment control BMPs. Final land contours will be illustrated on After Grading drawings, and may be required for During Grading drawings.

The E&SC drawings need numerous notes and “leaders” to inform contractors as to what is expected for minimizing impacts to the environment while construction activities occur (see example in Appendix V). Also, it is important to identify when part of a site is not to be immediately disturbed, illustration of sediment control measures to install are still shown. However, the contractor needs only to install and maintain those BMPs illustrated for lands where immediate disturbance activities occur.

Lastly, Designers, contractors, and regulatory agency personnel must understand that items identified on Pre Grading drawings are only a preliminary assessment of what may be required. Modifications to the drawings will be necessary while construction activities occur. Finally, Designers are encouraged to explore relevant updates with the contractor and regulatory agencies.

#### During Grading Drawings

The primary goal of any E&SC drawing while construction activities are occurring is to have clear illustrations for the contractor to install and maintain BMPs that ensure optimal treatment of concentrated runoff waters as land disturbance activities happen. This means that the Designers must clearly illustrate on their drawings what methods to install at critical discharge points to treat runoff while major land disturbance activities occur.

Grading of the land requires many different tasks to be completed simultaneously. In addition to major land disturbance, installation of storm sewer systems, development and paving of roads, grading land for building pads, and numerous other construction activities occur. It is for this reason that designers need to develop easy-to-read and effective During Grading drawings for the contractor of sediment and erosion control measures to implement, inspect, and maintain. Like Pre Grading plans, more than one drawing may be required.

During Grading plans shall contain detailed drawings using the same scale as pre grading plans to clearly illustrate the project site as well as include a north arrow, legend, date, elevation datum, and so forth. In addition, During Grading drawings shall include at least the following information:

1. Project boundaries and limits of soil disturbance.
2. Existing (try not to include proposed, if feasible) contours throughout, *and at least 50 feet outside the perimeter of*, the project site. Suggested contour intervals are 0.5- to 2-feet apart, but others may be necessary to ensure clarity of the plan.
3. Boundaries for undisturbed riparian buffer strips.
4. Extent of construction lines within which major land disturbance activities are to occur along with historic flow arrows.
5. Outline of the project footprint that illustrates boundaries, roads, layout, and so forth.
6. Identifying approximate locations of where to install structural (i.e., sediment control) BMPs *while* construction activities occur. For some agencies, it may be necessary to illustrate “Owners Pay Item Structure” for the BMPs (see Appendix V).
7. Identifying approximate locations of where to install nonstructural (i.e., erosion control) BMPs while construction activities are occurring (reference to After Grading drawings may be necessary). For some agencies, it may be necessary to illustrate “Owners Pay Item Structure” for the BMPs (see Appendix V).
8. Notes that indicate the contractor’s responsibility for locating and reporting where (as well as where not) topsoil stockpiles, staging areas, equipment storage, refueling/maintenance areas, and disposal areas are to exist.
9. Minimum requirements for inspection and maintenance of BMPs.

During Grading drawings illustrate to the contractor critical “containment” contours to ensure that optimal treatment of runoff from the disturbed lands will occur. Essential to this process is

to illustrate on During Grading drawings what BMPs to install at critical discharge points. This means Designers must develop their drawings so that contractors can clearly envision the BMPs to install for major grading activities (see example in Appendix V).

As with Pre Grading drawings, Designers, contractors, and regulatory agency personnel must understand that During Grading drawings are only a preliminary assessment of what BMPs may be required. Modifications to the drawings may be necessary while construction activities occur and Designers are encouraged to explore relevant updates with the contractor and regulatory agencies.

#### After Grading Drawings

Contractors also need a set of drawings that clearly illustrate how the site will appear After Grading activities are completed. Special consideration may be needed for each of the four (i.e., large land, linear, vertical, and big box) different types of projects. These drawings will also need instructions on removing unnecessary sediment control measures (see example in Appendix V).

One of the main purposes of After Grading drawings is to illustrate where to install erosion control practices for final stabilization of the disturbed lands. Included on these plans are such items as installing sod, planting seed, applying mulch, swale protection, hillside BMPs, and so forth. Another important aspect of After Grading drawings is to clearly illustrate what must occur while building activities happen. As with the previous drawings discussed, more than one drawing may be required.

After Grading plans shall contain detailed drawings using the same scale as Pre Grading plans. In addition, all plans must clearly illustrate the project site as well as include a north arrow, legend, date, elevation datum, and so forth. Finally, After Grading drawings shall include at least the following information:

1. Project boundaries and adjacent lands.
2. Proposed (do not include existing unless topography does not change) contours throughout, *and those existing at least 50 feet outside the perimeter of*, the project site. Suggested contour intervals are 0.5- to 2-feet apart, but others may be necessary to ensure clarity of the plan.
3. Developed basin drainage boundaries and accompanying flow arrows.
4. Boundaries for undisturbed riparian buffer strips.
5. Outline of the project footprint that illustrates lot boundaries, roads, layout, and so forth.
6. Illustrations of where re-establishment of permanent vegetation on disturbed lands are to occur. For some agencies, it may be necessary to illustrate “Owners Pay Item Structure” for the BMPs (see Appendix V).
7. Illustrations where installations of other erosion control measures (e.g., riprap, RECPs, etc.) are to occur. For some agencies, it may be necessary to illustrate “Owners Pay Item Structure” for the BMPs (see Appendix V).
8. Instructions on removing unnecessary sediment control (e.g., silt fence barriers) BMPs once 70% vegetative cover and/or other stabilization measures exist.
9. Minimum requirements for inspection and maintenance of erosion control BMPs.



When final contours of a site are not available, regulatory agencies may waive what is required in Item No. 2. When such a waiver is granted, spot elevations will be necessary to clearly illustrate high points, flow directions and so forth.

Lastly, Designers, contractors, and regulatory agency personnel must understand that items identified on After Grading drawings are only a preliminary assessment of what may be required. Modifications to the drawings may be necessary while construction activities occur and Designers are encouraged to explore relevant updates with the contractor and regulatory agencies.

#### Typical Detail and Specification Sheets

Contractors need to install, inspect, and maintain BMPs in a manner that will be effective in removing sediment from runoff waters and minimize erosion. Designers need to provide adequate information about the details so that the contractor can visualize what needs to be installed. This means keeping wording about BMPs on a specification sheet to a minimum. Instead, let the details provide basic information for the contractor about BMPs.

Appendix V illustrates an example of how details and specifications may appear. Do not clutter these sheets with meaningless information and material. Illustrate only those BMPs that are pertinent to the project and recommended to be installed on construction sites as shown on the E&SC drawings. However, do not limit the contractor from installing other BMPs when regulatory agencies and/or the designer give approval for their use and implementation.

#### Miscellaneous Comments

Perhaps the greatest fallacy that Designers and contractors have with designing and implementing a SWPPP and E&SC plan, respectively, lies with their over-reliance on sediment control BMPs. The only structural practice to effectively reduce sediment in runoff from construction sites is a properly designed SCS (a.k.a., sediment basin, pond, or trap) that treats a majority of site stormwater. Failure to minimize sediment leaving a construction site will be the norm when relying solely upon sediment barriers, such as silt fences or rock barriers, in front of inlets.

While ineffective sediment barriers may be the only alternative BMP to consider, they must be viewed as being only a temporary mitigation measure. Designers need to strategically place notes on their E&SC drawings that alert contractors to their obligation of implementing cost effective and practical erosion control practices while grading and construction activities occur. Examples of such practices might include (but not be limited to) applying sod, planting temporary or perennial grass seed, applying mulch and/or soil binder, installing inexpensive erosion control blankets, and so forth.

Finally, Designers need to impart the message that E&SC drawings are (at best) only an estimate of what needs to be done on the construction site. It is for this reason that contractors need to be aware that E&SC drawings are subject to additional, new and alternative BMPs when requested or approved by the Designer and/or regulatory agency.

#### E&SC Drawing Summary

Some of the more important items Designers need to consider when developing their E&SC drawings include:

- Remember that development of E&SC drawings are for the contractor.

- Research existing conditions of the site, including drainage patterns, inflow and outflow locations for runoff, soils, sensitive areas, and so forth.
- Use only existing contours on Pre- and (if feasible) During Grading drawings.
- Use only proposed contours and/or spot elevations on After Grading drawings.
- After grading, drawings may need to include sufficient information about the use of BMPs while building activities occur.
- Include sufficient notes and leaders about the BMPs.
- Provide accurate and complete detail drawings and simple specifications.
- Identify inspection and maintenance requirements.

**This page intentionally left blank**

**SECTION III**  
**EROSION CONTROL METHODS**

## Table of Contents

<b>INTRODUCTION .....</b>	<b>1</b>
<b>USE OF VEGETATION .....</b>	<b>1</b>
MAINTAINING ESTABLISHED VEGETATION .....	1
VEGETATIVE FILTER STRIPS .....	1
ESTABLISHING VEGETATION.....	2
<i>Sod</i> .....	2
<i>Permanent Vegetation</i> .....	2
<i>Temporary Vegetation</i> .....	2
<i>Planting Seed</i> .....	3
<i>Pure Live Seed Rates vs. Bulk Rates</i> .....	3
<i>Methods of Planting Seed</i> .....	3
<i>Polymer Enhanced Soil Stabilization</i> .....	4
MULCHES.....	4
<i>Dry Mulches</i> .....	5
<i>Compost Materials</i> .....	5
<i>Hydraulic Mulches</i> .....	6
SOIL BINDERS .....	6
<b>ROLLED EROSION CONTROL PRODUCTS.....</b>	<b>6</b>
RECPs FOR DISTURBED SLOPES .....	7
SOFT ARMORING RECPs FOR CONCENTRATED FLOWS .....	11
<i>Small Drainage Channels RECPs</i> .....	11
<i>Selecting a RECP for Small Drainage Channels</i> .....	11
<b>RUNOFF CONTROL STRUCTURES.....</b>	<b>19</b>
DIVERSION DIKES AND CONVEYANCE CHANNELS .....	19
SLOPE DRAINS FOR BASINS.....	20
SLOPE DRAINS FOR ROADS .....	23
CHANNEL CHECK STRUCTURES .....	28
<i>Spacing of Check Structures</i> .....	28
<b>EXAMPLES .....</b>	<b>35</b>
CHANNEL RECP FOR A SPECIFIC FLOW .....	36
BASIN SLOPE DRAIN .....	38
ROADWAY SLOPE DRAIN .....	38

**Summary Sheets for Erosion Control BMPs**

Rolled Erosion Control Product for a Disturbed Slope ..... **9**  
Rolled Erosion Control Product for a Drainage Channel ..... **16**  
Slope Drain for Small Basins..... **21**  
Slope Drain for Road Embankments ..... **24**  
Geosynthetic Barrier Check Structure ..... **31**  
Rock Barrier Check Structure..... **33**

## Table of Figures and Tables

FIGURE III-1:	DISTURBED SLOPE RECP SELECTION GUIDE (ECTC, 2004). .....	7
FIGURE III-2:	ILLUSTRATION OF INSTALLING A RECP ON A DISTURBED SLOPE .....	10
FIGURE III-3:	CHANNEL CROSS-SECTION EQUATIONS (NRCS, 1950) <b>ERROR! BOOKMARK NOT DEFINED.</b>	
FIGURE III-4:	ILLUSTRATION OF INSTALLING A RECP IN A DRAINAGE CHANNEL .....	18
FIGURE III-5:	INSTALLING A SLOPE DRAIN ON A DISTURBED SLOPE .....	22
FIGURE III-6:	INSTALLING A SLOPE DRAIN FOR ROAD EMBANKMENTS .....	26
FIGURE III-7:	CONTAINMENT CHAMBER FOR A ROAD EMBANKMENT SLOPE DRAIN .....	27
FIGURE III-8:	PLACEMENT OF CHECK STRUCTURES FOR CHANNEL STABILITY.....	28
FIGURE III-9:	RECOMMENDED SPACING OF BARRIERS IN DRAINAGE CHANNELS WHEN INSTALLED AS EROSION CONTROL MEASURES .....	29
FIGURE III-10:	GEOSYNTHETIC BARRIER CHECK STRUCTURE FOR SMALL DRAINAGE DITCHES.....	32
FIGURE III-11:	ROCK CHECK STRUCTURES IN SMALL DRAINAGE CHANNELS.....	34
FIGURE III-12:	ZONES FOR PRECIPITATION INTENSITY DURATION FREQUENCY CURVES AS DEVELOPED BY THE FDOT (2001) .....	40
FIGURE III-13:	RAINFALL INTENSITY DURATION FREQUENCY CURVE FOR ZONE 1 (FDOT, 2001) .....	41
FIGURE III-14:	RAINFALL INTENSITY DURATION FREQUENCY CURVE FOR ZONE 2 (FDOT, 2001) .....	42
FIGURE III-15:	RAINFALL INTENSITY DURATION FREQUENCY CURVE FOR ZONE 3 (FDOT, 2001) .....	43
FIGURE III-16:	RAINFALL INTENSITY DURATION FREQUENCY CURVE FOR ZONE 4 (FDOT, 2001) .....	44
FIGURE III-17:	RAINFALL INTENSITY DURATION FREQUENCY CURVE FOR ZONE 5 (FDOT, 2001) .....	45
FIGURE III-18:	RAINFALL INTENSITY DURATION FREQUENCY CURVE FOR ZONE 6 (FDOT, 2001) .....	46
FIGURE III-19:	RAINFALL INTENSITY DURATION FREQUENCY CURVE FOR ZONE 7 (FDOT, 2001) .....	47
FIGURE III-20:	RAINFALL INTENSITY DURATION FREQUENCY CURVE FOR ZONE 8 (FDOT, 2001) .....	48
FIGURE III-21:	RAINFALL INTENSITY DURATION FREQUENCY CURVE FOR ZONE 9 (FDOT, 2001) .....	49
FIGURE III-22:	RAINFALL INTENSITY DURATION FREQUENCY CURVE FOR ZONE 10 (FDOT, 2001) .....	50
FIGURE III-23:	RAINFALL INTENSITY DURATION FREQUENCY CURVE FOR ZONE 11 (FDOT, 2001) .....	51
TABLE III-1:	MANNING’S ROUGHNESS COEFFICIENTS FOR VARIOUS MATERIALS (FIFIELD, 2004) .....	13
TABLE III-2:	PERMISSIBLE SHEAR-STRESS VALUES AND VELOCITIES FOR VARIOUS MATERIALS (FIFIELD, 2004) .....	14
TABLE III-3:	RUNOFF COEFFICIENTS FOR THE RATIONAL METHOD (FDOT, 1987) .....	39

## **Introduction**

Sediment control practices remove some, but rarely all, particles suspended in runoff waters. It is for this reason that erosion control practices are an essential part of any E&SC plans to minimize the forces of raindrops, concentrated flows, and wind from detaching and transporting soil particles. Examples of erosion control include:

- Maintaining, establishing, and using vegetation
- Applying and maintaining mulches
- Applying soil tackifiers
- Diverting and controlling runoff waters

Good erosion control practices result in good sediment control, yet the opposite is not true. Thus, sediment control practices should always be considered as *secondary* (yet sometimes the only) treatments for construction sites. More importantly, as the effectiveness of erosion control practices increases, the need for sediment control will diminish. Hence, it is important for Designers to clearly identify to contractors through their E&SC drawings that stabilization of disturbed lands must occur as construction activities happen.

## **USE OF VEGETATION**

The optimal erosion control practice is to maintain existing vegetation or when lands are disturbed, establish new vegetation. As with check dams, vegetation can serve two purposes, namely, capture sediment and minimize erosion. Additional information on coastal vegetation appears in Appendix I.

### ***Maintaining Established Vegetation***

One of the most effective methods for minimizing erosion is to only disturb areas immediately needed for construction. By "staging" land-disturbance activities, existing vegetation reduces the potential for sediment generation due to erosion of bare ground. Existing vegetation also provides "buffer strips" to remove suspended particles from sheet flows. This is important when construction activities occur near watercourses.

When possible, existing vegetated drainage channels should not be disturbed during initial land clearing stages of a project. Leave these drainage channels stabilized until the new drainage system is in place or until the earthwork phase of the project precludes their continued use and a temporary drainage system is established.

### ***Vegetative Filter Strips***

Vegetative Filter Strips (VFS) are examples of what can be done for sediment and erosion control. When flows pass over and through these strips, large suspended particles (e.g. sands and silts) settle within a short distance. Finer particles (e.g. clays) are carried the furthest before settling and may stay suspended if runoff velocity remains high.

The following provides a summary of VFS ability to reduce sediment in runoff waters:

- They can effectively remove sediment in runoff water when *shallow or sheet flow* conditions exist or ponding can occur. Some reduction of sediment may occur for concentrated flows.



- As sediment accumulates on the strips, they become less effective; however, with slow accumulations, grass re-growth may restore the filtering capacity.
- Larger diameter particles (sands and silts) are removed first. Small particles (e.g. clays) settle more slowly and may experience limited removal due to strip width and flow rates.

It is recommended that VFS have a minimum width of 25 feet. However, widths may be dependent upon site conditions and local regulatory requirements. Also, when Designers recommend this form of sediment control, they must clearly identify the need for continual maintenance of the strips.

### ***Establishing Vegetation***

The most efficient and economical method for controlling erosion and minimizing sediment yields is to establish a vegetative cover. Two common methods used in Florida are to place and establish sod on disturbed lands or plant seed.

#### Sod

Sod provides a quick and relatively inexpensive method for establishing vegetation, but can be very labor intensive. While sod planted on a disturbed slope provides nearly instantaneous vegetation establishment, it cannot be classified as a success within drainage channels until root establishment.

#### Permanent Vegetation

Designers may find that it is more economical and practical to establish vegetation by planting seed rather than using sod. Permanent vegetation usually requires a perennial grass or legume to be used. Whenever possible, Designers should specify plant species that are native to the local area. Permanent vegetation is recommended for:

1. Final graded or cleared areas where permanent vegetative cover is needed to stabilize the soil.
2. Slopes designated to be treated with erosion control blankets.
3. Drainage channels or waterways designed to be protected with channel liners.

#### Temporary Vegetation

Rapidly growing annuals and legumes are examples of temporary vegetation recommended for disturbed lands that:

1. Will not be brought to final grade within seven (7) days or are likely to be re-disturbed.
2. Require seeding of cut and fill slopes under construction.
3. Require stabilization of soil storage areas and stockpiles.
4. Require stabilization of temporary dikes, dams, and sediment containment systems (SCSs).
5. Require development of cover or nursery crops to assist with establishment of perennial grasses.

Examples of temporary vegetation include wheat, oats, barley, millet, and Sudan grass.

### Planting Seed

Advantages of planting seed to establish vegetation include:

- Low initial costs
- Reduction of expenses associated with sediment control
- Low labor requirements
- Ease of establishing vegetation in difficult areas

Some disadvantages of planting seed are:

- The potential for erosion exists during the establishment stage
- The potential exists for the need to re-seed areas that fail
- Sufficient moisture conditions might not exist in a timely manner for germination of the seed

Seed selection may involve warm season, cool season, or a combination of both types of grasses. Usually, Florida will use warm season grasses that prefer warmer climatic and soil conditions to germinate. Cool season grasses germinate under cooler climatic and soil conditions.

### Pure Live Seed Rates vs. Bulk Rates

Not all seeds applied on bare ground will germinate. Likewise, seed-harvesting techniques do not result in the capture of a single grass species. Thus, Designers should express seed specifications as pure live seed (*PLS*) rather than in only bulk rates. The following equation illustrates how to calculate the percentage of *PLS* in a seed mixture:

$$PLS (\%) = [\text{purity} (\%) \times \text{germination} (\%)] \quad \text{Equation 1}$$

For example, if a specific seed is tagged as being 95% pure with an 81% germination rate, then the  $PLS = 95\% \times 81\% = 77.0\%$ .

Another way to specify seed mixture application rates is to use "bulk rates." However, bulk rates do not provide information on seed purity and germination rates. When bulk-rate application rates are specified, they are calculated by the following equation:

$$\text{Bulk Rate} = PLS \text{ Rate} \div PLS \text{ Percentage} \quad \text{Equation 2}$$

Thus, if the *PLS* application rate of the above seed is 25.4 *lbs./ac.*, then the bulk rate is  $25.4 \text{ lbs./ac.} \div 77.0\% = 33.0 \text{ lbs./ac.}$

Additional information of selection of species and their application rates can be found from local Natural Resource Conservation Service (NRCS), regulatory agencies, and through seeding and mulching companies.

### Methods of Planting Seed

One or more of the following methods can be used to plant seed:

1. Drill
  - a) Seed is in direct contact with the soil
2. Broadcast
  - a) Seed is on top of the ground.

- b) Raking is required to ensure seed is covered with soil.
- c) Application rate of seed is 2x to 4x times the drilled rate.

3. Hydraulic

- a) Seed is part of the slurry mixture applied on the soil.
- b) Application rate of seed is 5x to 6x the drilled rate.

Polymer Enhanced Soil Stabilization

If there is a requirement for increased erosion protection of disturbed slopes, Designers can consider adding polymers to the soil before applying soil binders, mulch, or erosion control blankets (see below).

Polymer additions can assist in the temporary or permanent establishment of grass by binding the seed, fertilizer, mulch, and soil together until germination happens. However, it is important that dosage rates be determined based upon site conditions (see Appendix III for more information).

Polymer dosage rates will vary with site-specific applications along with water and soil requirements. Using information found in Appendix III, the following rates might be applicable once site-specific conditions have been evaluated:

SOIL TYPE	SLOPE IS LESS THAN 1V:3H	SLOPE IS 1V:3H TO 1V:1H
HIGH CLAY CONTENT	10 TO 20 LBS/ACRE	20 TO 35 LBS/ACRE
HIGH SAND CONTENT	15 TO 20 LBS/ACRE	25 TO 50 LBS/ACRE

It is important that Designers work with professionals that are experienced in using polymers on construction sites. In this manner, potential environmental problems can be professionally addressed and problems avoided.

***Mulches***

Mulches are applied over the soil surface to reduce erosion from rainfall and wind. They are also used to aid the establishment of vegetation. Some typical uses for mulches include:

- Reduce soil erosion by wind and raindrop impact through temporary soil stabilization
- Providing cover until vegetation can be established
- Adding soil amendments such as organic matter and fertilizers
- Improving soil structures
- Decrease the velocity of runoff over exposed soil areas, which increase the infiltration of water

Mulches can be used alone (usually temporarily) as a protective blanket on the soil. However, it is best to plant seed prior to any application of mulch. In this manner, vegetation will become available for erosion protection. Additional information on using mulches within coastal areas appears in Appendix I.

All mulches have limitations. For example, they are not suitable for areas with high tidal fluctuations, heavy wave action or where concentrated flows exist. In addition, some materials are susceptible to removal or disturbance by wind in exposed areas.

Successful use of dry or hydraulic mulches is dependent upon a rapid establishment of vegetation. Once vegetation becomes well established, and minimal amounts of weeds are present, erosion protection is provided by the vegetation root system and canopy cover.

#### Dry Mulches

Mulches can be classified as “dry” or “wet” products. Dry mulches usually consist of organic or inorganic materials, whereas wet mulches are applied with hydraulic equipment and also consist of organic materials.

Dry mulches can consist of:

- Certified noxious weed free straw or hay
- Compost materials, including wood or bark chips
- Rolled Erosion Control Products (RECPs)
- Rock

The standard application rate of straw/hay mulch is about 2.0 tons/acre with 80% to 100% ground coverage of material having minimum fiber lengths of 6.0- to 8.0-inches. Dry mulches must be held in place, usually by crimping, which forces, or punches, fibers into the ground by use of a weighted disk.

When straw/hay mulch fibers are short, anchoring material by crimping usually will not occur and removal by wind happens. A tackifier can overcome some wind removal problems by “gluing” the fibers together. However, strong winds could still remove sections of tackified dry mulches.

#### Compost Materials

A cost-effective method of developing dry mulch is to shred existing vegetation during clearing activities. This type of mulch, also known as compost material, can include:

- Dry straw/hay
- Wood chips, bark, cellulose fiber, or excelsior
- Other vegetative trimmings such as grass, shredded shrubs, and trees

An advantage of compost material is that vegetation removed during grading activities can be quickly ground or shredded and immediately applied onto disturbed lands. Thus, mulch is available during and after grading activities and may contain seeds of local grasses, bushes, and trees.

Unless there are some undesirable species in the compost material, it can often be applied adjacent to the soil/water interface. However, one possible limitation about compost is that it may contribute to water quality degradation. For example, it is possible that the introduction of organic (tannic) acids and dissolved organic carbon from decaying plant material to nearby coastal water bodies can occur.

### Hydraulic Mulches

Hydraulic mulches have an advantage in that they can cover the ground but do not have to be crimped as with dry mulches. They are a mixture of shredded wood, paper, or corn stalk fiber and often include a stabilizing emulsion, tackifier, or polymer that can be applied with specialized equipment. However, without a "tackifier" to help bind the material, hydraulic mulches are susceptible to removal by precipitation and runoff.

The standard application rate of hydraulic mulches is 1.5 tons/acre. As with straw or hay, it is important that 80% to 100% ground coverage by material occurs.

### ***Soil Binders***

When dry mulch cannot be crimped, other methods to control erosion or hold fibers in place must be used. Soil binders and tackifiers have been developed to accomplish this task with examples including:

- Tackifying straw or hay mulches
- A component of hydraulic mulches and matrices
- Dust-control products

An excellent use of soil binders is to temporarily stabilize cut and fill areas. These low-cost erosion control products provide an effective, temporary method to reduce sediment leaving construction sites. However, soil binders should not be depended upon for more than three to six months as an erosion control practice. Also, they do not replace the need for permanent vegetation establishment by planting seed and mulching.

## **ROLLED EROSION CONTROL PRODUCTS**

Rolled Erosion Control Products (RECPs) are manufactured mulch materials used to protect disturbed soils from erosion. They are also known as erosion control blankets or mats. All RECPs reduce the erosion process and create conditions to assist in establishing vegetation. They also allow for increased infiltration, conserve soil moisture, and help keep seed in place.

RECPs are composed of organic and/or inorganic materials. Organic materials are subject to both biological- and photo-degradation processes. Thus, they may degrade within three to 12 months. The inorganic materials may or may not be photodegradable and are less susceptible to the degradation processes. Examples of RECP materials include the following:

- Straw
- Coconut and related fibers
- Wood excelsior
- Jute
- Polypropylene
- Nylon

In addition to the above materials, combinations of different material can be used (e.g. straw and coconut).

All RECPs require a method to keep the material in place. Usually, this consists of a polypropylene netting placed on one or both sides of the material. Designers should evaluate the use of "net less" blankets or those RECPs using degradable netting that break down within specific project requirements.

**RECPs for Disturbed Slopes**

Significant reduction of erosion and good establishment of vegetation on disturbed slopes will occur by using properly installed RECPs. When establishing vegetation on disturbed slopes, organic RECPs are usually used. However, there may be situations where inorganic materials will be required.

Figure III-1 provides guidelines for selecting RECPs for disturbed slopes based upon criteria developed by the Erosion Control Technology Council (ECTC). Detailed information about the different types of products appears after Figure III-1.

While additional information is presented about the different types of RECP products, Designers are encouraged to obtain and review more detailed material found on the ECTC web site by accessing [www.ectc.org](http://www.ectc.org).

**Disturbed Slope (V:H)**

	1:5	1:4	1:3	1:2	1:1.5	1:1	1:0.5		
< 3	TYPE 1a	TYPE 1b	TYPE 1c	TYPE 1d					
3 - 12	TYPE 2a	TYPE 2b	TYPE 2c	TYPE 2d					
12 - 24	TYPE 3a	TYPE 3b	TYPE 3c	TYPE 3d				TYPE 3d	
24 - 36	TYPE 4a	TYPE 4b	TYPE 4c	TYPE 4d				TYPE 4d	TYPE 4d
>36	TYPE 5 a,b,c								

**Figure III-1: Disturbed Slope RECP Selection Guide (ECTC, 2004 and latest edition).**

- Type 1 products are lightweight and typically are composed of single/double net straw or excelsior material, as well as jute.
- Type 2 products are more durable than Type 1 products and typically may be composed of single/double net straw or excelsior material, as well as jute.
- Type 3 products are more durable than either Type 1 or Type 2 products and typically may be composed of double net straw, straw-coconut, coconut, and excelsior, as well as jute.
- Type 4 products are expected to remain a viable erosion control material for long durations.
- Type 5 products are expected to have long-term functional longevity and are typically composed of polyolefin fibers, polypropylene, and nylon. Some products may be excelsior or a combination of polypropylene and straw-coconut/coconut material.

Some typical examples of the letter designation are:

1a, 2a, 3a – "netting only" used over Mulch (synthetic or natural ) with 3, 12, or 24 month life.

- 1b, 2b – “net less” Erosion Control Blanket – usually 3 or 12 month life.
- 1c, 2c - Single Net Erosion Control Blanket or Open Weave Textile – 3 or 12 month life.
- 1d, 2d - Double Net Erosion Control Blanket - 3 or 12 month life.
- 3b - Double Net Erosion Control Blanket or Open Weave - 24 month life.
- 4 - Double Net Erosion Control Blanket or Open Weave - 36 month life.
- 5a, 5b, 5c - Permanent Erosion Control Blanket - 6, 8, or 10 lb/sf shear stress limits.

These designations may change with time and are subject to labeling practices, thus the users should consult the latest manufacturer and industrial standard publications when specifying a RECP. Additional information on installing disturbed slope RECPs appears in Figure III-2.

### Rolled Erosion Control Product for a Disturbed Slope

#### **WHAT IS ITS PURPOSE?**

To protect disturbed slope surfaces against erosion due to rainfall or flowing water.

#### **WHERE AND HOW IS IT COMMONLY USED?**

- Installed on slopes or embankments.
- Where steep slopes exist.
- Used as mulch after seeding has occurred.
- Where vegetation is difficult to establish.

#### **WHEN SHOULD IT BE INSTALLED?**

- While construction activities are occurring.
- After Grading activities are finished.

#### **WHEN SHOULD IT NOT BE INSTALLED?**

- Over very rough ground having extensive amounts of rock, rills, or gullies.
- On slopes where weeds are established.

#### **WHAT NEEDS TO BE INSPECTED?**

- Does the RECP have any tears or other damage to it?
- Is water flowing under the blanket and causing erosion?
- Was it installed correctly?
- Did planting of seed occur before installing the RECP?
- Is the material secured to the slope with a sufficient number of staples?
- Was the top of material secured in a trench or by some other method?

#### **WHAT MAINTENANCE ACTIVITIES CAN BE EXPECTED?**

- Repair and replacement of material.
- Repair of eroded ground.

#### ***NOTES***

- RECPs are composed of natural material including straw, straw-coconut, coconut (or coir), wood excelsior, and so forth. They must be held in place with netting sewn on both sides of the material.
- Material must be placed in an uphill trench or adequately stapled.
- Additional information on RECPs can be found at [www.ectc.org](http://www.ectc.org).



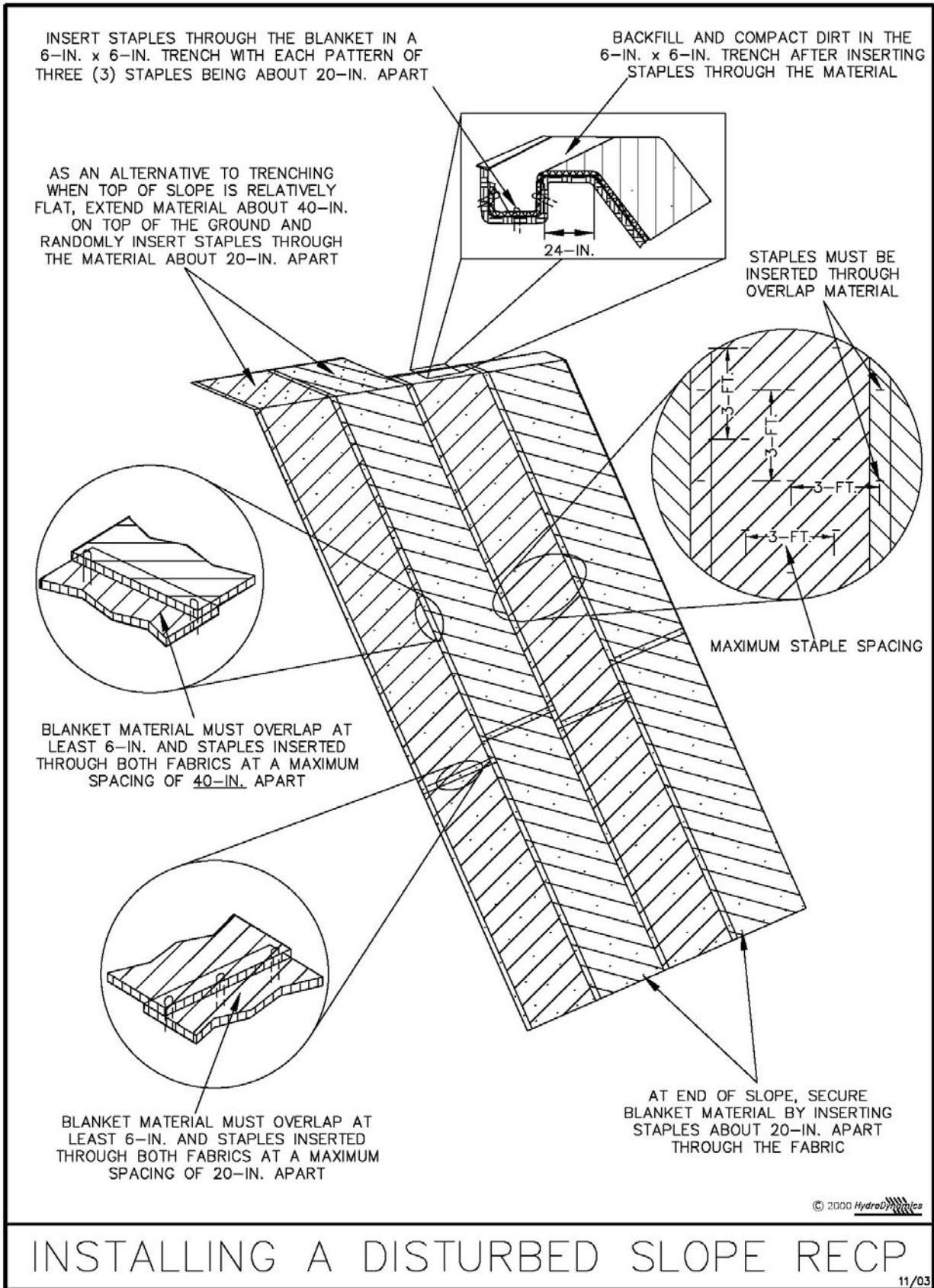

**Figure III-2: Illustration of Installing a RECP on a Disturbed Slope**

Permission is given by HydroDynamics Incorporated to copy and reproduce this detail

***Soft Armoring RECPs for Concentrated Flows***

When water flows within roadside drainage ditches or into/out of culverts, intense hydraulic conditions exist that will cause erosion of stream embankments or channel beds. Similar hydraulic problems can occur with wave action on reservoir shorelines.

A common method used by Designers for protecting exposed soils against erosion is to install riprap, concrete structures, gabions or some other hard armoring. These methods have proven to be successful in controlling erosion of drainage channels and stream banks. However, "soft armoring" RECPs can provide an alternative to the traditional hard armors.

**Small Drainage Channel RECPs**

Vegetation usually provides the best method for reducing erosion in drainage channels. However, establishing vegetation in bare ground drainage channels is difficult when flows occur. Not only will the water remove seed and mulch, the kinetic energy of runoff causes erosion. Use of RECPs in channels may alleviate this problem.

Two types of RECPs can be used in drainage channels: Erosion Control Blankets (ECBs) and Turf Reinforcement Mats (TRMs). An ECB is the same organic material described previously for protecting hillsides against erosion. As with disturbed slope products, planting of seed must occur prior to installing the mat. The main purpose of an ECB is to provide temporary protection for grass seed to germinate and become established within the drainage channel. However, erosion problems may occur when the ECB deteriorates or is destroyed by high flows. It is for this reason that consideration needs to be given to using TRMs.

The EPA (1999) describes TRMs as being composed of interwoven layers of non-degradable geosynthetic materials such as polypropylene, nylon, and polyvinyl chloride netting, stitched together to form a three-dimensional matrix. A TRM can also consist of organic materials (e.g. coconut or straw) combined with geosynthetic products.

TRMs are thick and porous enough to allow for planting seed and filling with soil. In this manner, conditions will exist to allow for development of a root structure within the matrix. However, until the establishment of vegetation occurs, seed and soil may wash away due to runoff events. Planting seed directly onto the channel overcomes this problem.

Figure III-4 illustrates installation procedures for ECBs and TRMs in drainage channels.

**Selecting a RECP for Small Drainage Channels**

The most important item Designers need to consider in selecting an ECB or TRM is whether the product will be able to withstand anticipated shear stress forces and flow velocities. The following provides information on how this is determined.

Selecting a RECP for a small drainage channel (e.g. roadside ditch) requires proper evaluation of shear stress and flow velocity so that either an ECB or TRM is selected. Velocity of flows in channels can be calculated by use of Manning's Equation.

$$V = (1.486 + n) \times R^{2/3} \times S^{1/2} \quad \text{Equation 3}$$

where  $V$  = Mean velocity of flow (ft./sec.)

$R$  = Hydraulic radius =  $A/WP$  (ft.)

$WP$  = Wetted perimeter (ft.)

$S$  = Slope of the energy gradient (ft./ft.)

$n$  = Roughness coefficient

Table III-1 provides roughness coefficients for different types of channel materials and Figure III-3 can be used to calculate channel parameters having different geometric shapes.

Flow velocity is not the only parameter to calculate when selecting an ECB or TRM for stabilizing small drainage channels. Shear stress must also be evaluated since it represents the frictional forces of water. Maximum shear stress occurs on the bottom material of a channel and is represented by:

$$\tau_{\max} = 62.4 \times Y \times S \quad \text{Equation 4}$$

where  $\tau_{\max}$  = Maximum shear stress (lbs./ft.<sup>2</sup>)

$Y$  = Depth of water (ft.)

$S$  = Slope of the energy gradient (ft./ft.)

Table III-2 provides permissible shear stress and flow velocities for different products and natural conditions.

Finally, Designers must remember that organic materials will biodegrade. Thus, selection of organic products must be based upon the maximum permitted shear stress values for *final vegetative conditions* rather than for the RECP material. However, it is important that any RECP selected be able to withstand anticipated shear stress and velocity until vegetation is established.

Additional information on selecting ECBs and TRMs in drainage channels can be found by accessing [www.ectc.org](http://www.ectc.org) or reviewing Fifield, 2004. An example of how to select a TRM or ECB appears in the example part of this section.

**Table III-1: Manning's Roughness Coefficients for Various Materials (Fifield, 2004)**

Material	Depth of 0 to 6 in.	Depth of 6 in. to 24 in.	Depth >24 in.
Bare soil <sup>a</sup>	0.023	0.020	0.020
Rock cut <sup>a</sup>	0.045	0.035	0.025
Gravel riprap <sup>a</sup>			
D50 = 1.0 inches	0.044	0.033	0.030
D50 = 2.0 inches	0.066	0.041	0.034
Rock riprap <sup>a</sup>			
D50 = 6.0 inches	0.104	0.069	0.035
D50 = 12 inches	---	0.078	0.040
Concrete <sup>a</sup>	0.015	0.013	0.013
Grouted riprap <sup>a</sup>	0.040	0.030	0.028
Stone masonry <sup>a</sup>	0.042	0.032	0.030
Soil cement <sup>a</sup>	0.025	0.022	0.020
Asphalt <sup>a</sup>	0.018	0.016	0.016
Fiberglass roving <sup>a</sup>	0.028	0.021	0.019
Straw (loose) covered with net <sup>a</sup>	0.065	0.033	0.025
<b>EROSION CONTROL BLANKET</b>			
Jute net <sup>a</sup>	0.028	0.022	0.019
Wood excelsior mat <sup>a</sup>	0.066	0.035	0.028
<b>TURF REINFORCEMENT MAT</b>			
Bare ground conditions <sup>b</sup>	0.036	0.026	0.020
Vegetation conditions <sup>b</sup>	0.023	0.020	0.020

a      Chen and Cotton (1988)

b      IECA (1995)

HYDRAULICS: ELEMENTS OF CHANNEL SECTIONS						
Section	Area $a$	Wetted Perimeter $p$	Hydraulic Radius $r$	Top Width $T$		
<p>Trapezoid</p>	$bd + zd^2$	$b + 2d\sqrt{z^2 + 1}$	$\frac{bd + zd^2}{b + 2d\sqrt{z^2 + 1}}$	$b + 2zd$		
<p>Rectangle</p>	$bd$	$b + 2d$	$\frac{bd}{b + 2d}$	$b$		
<p>Triangle</p>	$zd^2$	$2d\sqrt{z^2 + 1}$	$\frac{zd}{2\sqrt{z^2 + 1}}$	$2zd$		
<p>Parabola</p>	$\frac{2}{3} dT$	$T + \frac{8d^2}{3T}$	$\frac{2dT^2}{3T^2 + 8d^2}$	$\frac{3d}{2d}$		
<p>Circle - <math>&lt; 1/2</math> full <sup>2</sup></p>	$\frac{D^2}{8} (\frac{\pi\theta}{180} - \sin\theta)$	$\frac{\pi D\theta}{360}$	$\frac{45D}{\pi\theta} (\frac{\pi\theta}{180} - \sin\theta)$	$D \sin \frac{\theta}{2}$ or $2\sqrt{d(D-d)}$		
<p>Circle - <math>&gt; 1/2</math> full <sup>3</sup></p>	$\frac{D^2}{8} (2\pi - \frac{\pi\theta}{180} + \sin\theta)$	$\frac{\pi D(360 - \theta)}{360}$	$\frac{45D}{\pi(360 - \theta)} (2\pi - \frac{\pi\theta}{180} + \sin\theta)$	$D \sin \frac{\theta}{2}$ or $2\sqrt{d(D-d)}$		

<sup>1</sup> Satisfactory approximation for the interval  $0 < \frac{d}{T} \leq 0.25$   
 When  $d/T > 0.25$ , use  $p = \frac{1}{2}\sqrt{16d^2 + T^2} + \frac{T^2}{8d} \sinh^{-1} \frac{4d}{T}$   
<sup>2</sup>  $\theta = 4 \sin^{-1} \sqrt{d/D}$   
<sup>3</sup>  $\theta = 4 \cos^{-1} \sqrt{d/D}$  Insert  $\theta$  in degrees in above equations

Figure III-3: Channel Cross-Section Equations (NRCS, 1950)

**Table III-2: Permissible Shear-Stress Values and Velocities for Various Materials**  
**Note: there is a shear value for each product. (Fifield, 2004)**

Material	Test Time (hr.)	Maximum Shear Stress (lbs./ft. <sup>2</sup> )	Maximum Velocity (ft./sec.)
Bare soil <sup>a</sup>			
Non-cohesive (Diameter = 0.004 to 4.0 in.)	NDG	0.004 to 1.67	NDG
Cohesive Loose (Plasticity Index = 3.0 to 50)	NDG	0.01 to 0.090	NDG
Cohesive Medium Compact (Plasticity Index = 3.0 to 50)	NDG	0.015 to 0.27	NDG
Cohesive Compact (Plasticity Index = 3.0 to 50)	NDG	0.022 to 0.79	NDG
Gravel riprap <sup>a</sup>			
D <sub>50</sub> = 1.0 inches	NDG	0.31	NDG
D <sub>50</sub> = 2.0 inches	NDG	0.67	NDG
Rock riprap <sup>a</sup>			
D <sub>50</sub> = 6.0 inches	NDG	1.99	NDG
D <sub>50</sub> = 12 inches	NDG	3.99	NDG
Grass (established) <sup>a</sup>			
Height Classification      Examples			
<b>A</b> (30 in.)      Weeping lovegrass and Yellow bluestem	NDG	3.76	NDG
<b>B</b> (12 to 24 in.)      bermuda grass, Little bluestem, Bluestem, Blue gamma, and other long and short Midwest grasses	NDG	2.09	NDG
<b>C</b> (6 to 12 in.)      Crabgrass, bermuda grass, orchard grass, redtop, Italian ryegrass, Kentucky bluegrass, common lespedeza	NDG	1.05	NDG
<b>D</b> (2 to 6 in.)      bermuda grass, buffalo grass, orchard grass, redtop, Italian ryegrass, common lespedeza	NDG	0.63	NDG
<b>E</b> (1.6 in.)      bermuda grass	NDG	0.31	NDG
Fiberglass Roving <sup>a</sup>			
Single	NDG	0.61	NDG
Double	NDG	0.86	NDG
Straw (loose) covered with net <sup>a</sup>	NDG	1.44	NDG
<b>EROSION CONTROL BLANKET</b>			
Coconut material	0.5	2.26	9.8
Wood excelsior material <sup>a,b,c</sup>	NDG	0.50 to 2.00	4.9 to 7.9
Jute net <sup>a</sup>	NDG	0.45	NDG
Straw blanket with sewn net <sup>b,c</sup>	0.50	1.50 to 1.75	4.9 to 5.9
Straw/coconut blanket with sewn net <sup>b,c</sup>	0.5	2.00 to 2.10	7.9
<b>TURF REINFORCEMENT MAT</b>			
Bare Ground Conditions <sup>a,b,c</sup>	0.50	3.00 to 8.00	8.9 to 20.0
	50	2.00 to 3.00	7.9 to 14.1
Vegetation Established <sup>b,c</sup>	0.50	6.00 to 14.0	14.8 to 25.0
	50	6.00 to 12.0	9.8 to 14.1

a Chen and Cotton (1988)

b IECA (1991, 1992, 1995)

c As reported by the manufacturer

NDG = No data given

### Shear Diagram Information

$\tau$  = SHEAR (FRICTIONAL) STRESS

$F_{DN}$  = DOWNWARD STATIC PRESSURE

$F_{UP}$  = UPWARD STATIC PRESSURE

$W$  = WEIGHT OF WATER

$A$  = CROSS-SECTIONAL AREA

$F_{DN} = F_{UP}$

$W = \gamma \times A \times L$

$\sin \theta = \tan \theta = H / L$  FOR SMALL ANGLES

SLOPE =  $S = \tan \theta = H / L$

$\gamma$  = SPECIFIC WEIGHT OF WATER

$\Sigma$  FORCES DOWN =  $\Sigma$  FORCES UP

$F_{DN} + W \times \sin \theta = F_{UP} + P \times L \times \tau$

$F_{DN} + W \times H / L = F_{UP} + P \times L \times \tau$

$A \times L \times \gamma \times H / L = P \times L \times \tau$

$\tau = (\gamma \times A \times S) / P$       MEAN SHEAR STRESS

MAXIMUM SHEAR STRESS IS ON THE BOTTOM. THUS,  $P = X$

$\tau_{MAX} = (\gamma \times A \times S) / X$

$\tau_{MAX} = (\gamma \times Y \times X \times S) / X$

$\tau_{MAX} = \gamma \times Y \times S$       MAXIMUM SHEAR STRESS

© 2000 Hydro

### Rolled Erosion Control Product for a Drainage Channel

#### **WHAT IS ITS PURPOSE?**

To protect a drainage channel against erosion due to flowing water.

#### **WHERE AND HOW IS IT COMMONLY USED?**

- In drainage channels where vegetation needs to be established and significant flows occur. ▪

#### **WHEN SHOULD IT BE INSTALLED?**

- While construction activities are occurring.
- After Grading activities are finished.

#### **WHEN SHOULD IT NOT BE INSTALLED?**

- Over impervious surfaces.
- On very rough ground.

#### **WHAT NEEDS TO BE INSPECTED?**

- Does the RECP display any damage?
- Have check structures (staple or trench) been installed?
- Are sufficient numbers of staples used?
- Was seed planted before installing the RECP?
- Was the channel bed smooth when the RECP was installed?
- Is water flowing under the blanket and causing erosion?
- Is the correct material used?
- Should straw mulch be used?

#### **WHAT MAINTENANCE ACTIVITIES CAN BE EXPECTED?**

- Repair and replacement of material.
- Repair of eroded ground.

### ***NOTES***

- Erosion Control Blankets (ECBs) are composed of natural material including straw, straw-coconut, coconut (or coir), wood excelsior, and so forth. They must be held in place with netting sewn on both sides of the material.
- One type of Turf Reinforcement Mats (TRMs) is composed of 100% polypropylene or nylon and held in place with netting sewn on both sides of the material.
- Another type of TRM is composed of straw-coconut or coconut matter reinforced with strands of polypropylene threads and all held in place with netting sewn on both sides of the material.
- Designers must complete shear stress and velocity calculations in selecting an ECB or TRM for drainage channels.
- Additional information about ECBs and TRMs can be found at [www.ectc.org](http://www.ectc.org).



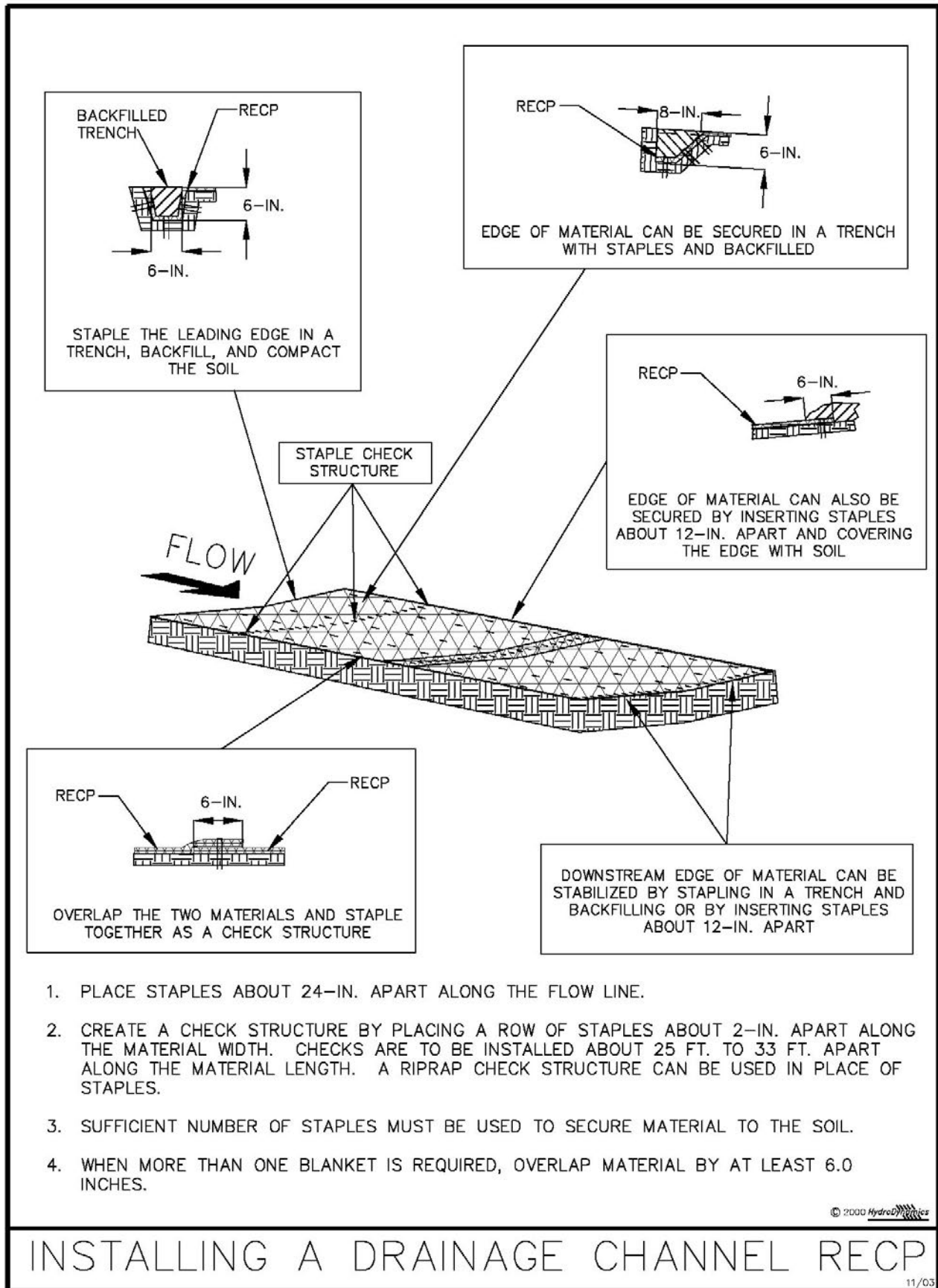

**Figure III-4: Illustration of Installing a RECP in a Drainage Channel**

Permission is given by HydroDynamics Incorporated to copy and reproduce this detail

## **RUNOFF CONTROL STRUCTURES**

Construction activities usually result in the removal of vegetative cover and increases in impermeable surfaces, both of which lead to an increase in the peak flood flows, velocity, and volume of runoff. Increases in runoff volume and velocity lead to increased erosion (i.e. rills and gullies), sediment transport, and offsite delivery (sedimentation). These increases must be addressed when implementing sediment and erosion control measures.

Runoff-control measures are practices that mitigate the erosive and sediment transport forces of stormwater during and after grading activities. Some examples of runoff control measures include:

- Outlet protection
- Temporary slope drains
- Vegetative buffer strips
- Grass-lined channels
- Diversion dikes and conveyance channels
- Rock-lined channels
- Check dams
- Wattles located along contours of a hillside

### ***Diversion Dikes and Conveyance Channels***

Diversion dikes will intercept and divert runoff waters in properly designed drainage conveyance channels. Essentially, diversion dikes can prevent runoff from flowing down a disturbed slope. Once these flows are reduced, rill and gully erosion will also be reduced.

Transporting runoff in drainage channels must be completed in a manner that minimizes erosion. Appropriate uses of diversion structures include the following:

- Diverting runoff from drainage areas away from disturbed areas and toward a stabilized outlet.
- Diverting sediment-laden runoff from a disturbed area into a sediment containment structure.
- Using a dike to divert runoff waters to a conveyance channel in a manner that improves working conditions at the construction site and minimizes erosion.
- Using a dike to ensure that sediment-laden stormwater will not leave the site without treatment.
- Using methods that are sometimes preferable over barriers because they are more durable, less expensive, and require less maintenance when properly constructed.

Any channel created by a dike must have a sufficient grade that forces flows to a stabilized outlet. When the channel slope is less than or equal to 1.0%, stabilization might be required for soils that generate turbidity in runoff waters. Channel slopes greater than 1.0% must be stabilized to prevent degradation.

Sediment-laden waters must be diverted into a properly designed sediment containment system (SCS). In addition, runoff from undisturbed lands must discharge onto an outlet protection system.

As with all methods to control sediment and erosion, frequent inspections and maintenance must occur with diversion dikes and conveyance channels. The following guidelines should be followed when conducting inspections and maintenance:

- Inspect temporary facilities before and after significant runoff events and at least once per week during the rainy season.
- Channel linings, embankments, and channel beds must be continually inspected for erosion.
- Removal of debris and prompt repairs should always occur.

### ***Slope Drains for Basins***

Slope drains consist of flexible tubing, pipe, or other conduit extending from the top to the bottom of a cut or fill slope. Their purpose is to convey runoff waters across (and usually down) erodible lands in a manner that prevents erosion.

It is important that slope drains be sized, installed, and properly maintained since their failure could result in severe slope erosion. Entrance to the pipe must be well entrenched and stable. Increased inflows can be realized by installing flared end sections on the pipe. Finally, the pipe should extend beyond the toe of the slope or into an appropriately stabilized outlet. Figure III-5 illustrates the placement of these conveyance structures.

When selecting the diameter of a pipe for slope drains, Designers must be cognizant of contributing basin areas and the accompanying hydrologic conditions. For example, runoff from contributing bare ground basins of sandy soils will be different from what occurs with flows from bare ground clay soils.

When a containment berm has a height that is at least twice the pipe diameter of a slope drain (see Figure III-5), the pipe diameter can be calculated from:

$$D = 4.29 \times Q^{0.50} = 4.29 \times (CiA)^{0.50} \quad \text{Equation 5}$$

Where  $D$  = Pipe diameter (inches)

$Q$  = Peak flood flow for the design storm event (*cfs*)

$C$  = Runoff coefficient

$i$  = Rainfall intensity (inches/hour)

$A$  = Contributing area (acres)

Located within the example part of this section is a table of runoff coefficients and Intensity Duration Frequency (IDF) curves for 11 FDOT regions throughout Florida.

Selections of the rainfall intensity should be based upon an average return period and the time of concentration for the site location, unless otherwise dictated by local regulations. The example at the end of this section illustrates the selection of a pipe diameter using the intensity of a 10-year return period.

### Slope drain for Small Basins

#### **WHAT IS ITS PURPOSE?**

To protect hillside surfaces against erosion due to concentrated flows of runoff waters.

#### **WHERE AND HOW IS IT COMMONLY USED?**

- On fill slopes.
- On cut slopes.

#### **WHEN SHOULD IT BE INSTALLED?**

- While construction activities are occurring.
- After Grading activities are finished.

#### **WHEN SHOULD IT NOT BE INSTALLED?**

- When contributory basins are large (usually greater than five acres).

#### **WHAT NEEDS TO BE INSPECTED?**

- Are there areas where the earthen berm has been breached?
- Is water discharging onto an embankment?
- Is there protection (i.e. riprap) at the end of the slope drain?
- Is water flowing around the slope drainpipe?
- Is the pipe secured to the hillside?

#### **WHAT MAINTENANCE ACTIVITIES CAN BE EXPECTED?**

- Repair or replacement of slope drain.
- Replacement of riprap.
- Repair breached sections of earthen berm.

#### **EQUATION USED TO CALCULATE PIPE DIAMETER:**

$$D = 4.29 \times Q^{0.50} = 4.29 \times (CiA)^{0.50}$$

Where  $D$  = Pipe diameter (inches)

$Q$  = Peak flood flow for the design storm event (*cfs*)

$C$  = Runoff coefficient

$i$  = Rainfall intensity (inches/hour)

$A$  = Contributing area (acres)

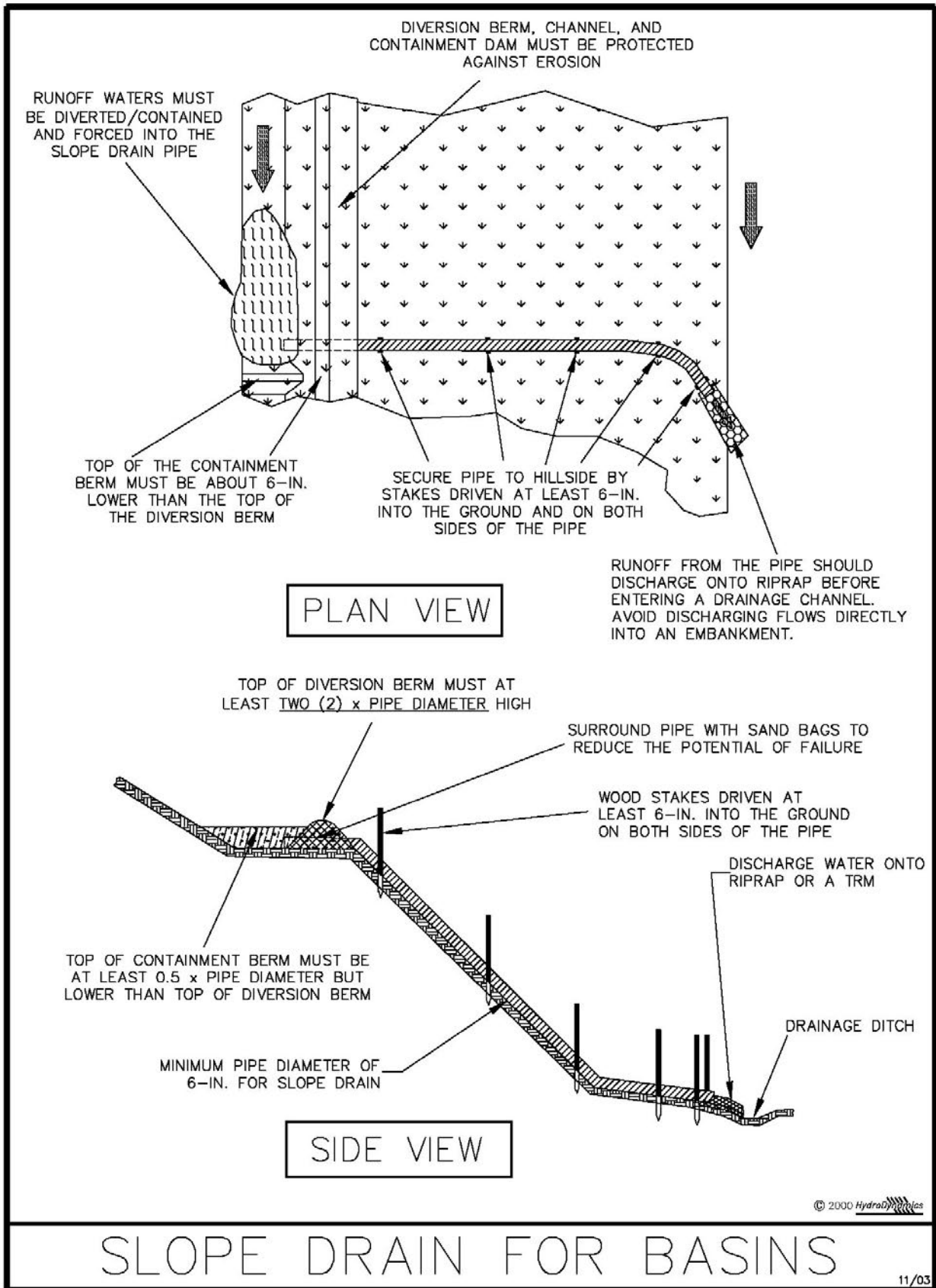

**Figure III-5: Installing a Slope Drain on a Disturbed Slope**

Permission is given by HydroDynamics Incorporated to copy and reproduce this detail

***Slope Drains for Roads***

Protecting fill slopes from developing rills and gullies due to runoff waters off a road is similar to what is required for basins. Use of high flow diversion dikes is not always possible or advisable since erosion control of a channel is not always feasible in a practical manner. However, placement of temporary slope drains along the top of a road embankment is feasible.

Spacing of temporary slope drains for roads are usually based upon pre-determined pipe diameters. What designers need to identify is the amount of runoff entering the pipe, which is dependent upon the width of the roadway. Figure III-6 and Figure III-7 illustrate placement of temporary roadway slope drains.

Assuming that a road has a rectangular shape and a containment berm along the side of the road has a height that is at least twice the pipe diameter of a slope drain, the spacing between each pipe can be calculated by:

$$L = (245.8 \times D^{2.5}) + (i \times W) \qquad \text{Equation 6}$$

Where  $L$  = Spacing between slope drains (feet)

$D$  = Slope drain pipe diameter (inches)

$i$  = rainfall intensity when the time of concentration is eight minutes (inches/hour)

$W$  = Average width of the road that contribute runoff to the slope drain (feet)

Located at the end of the section are examples of how spacing of pipes is calculated for different pipe diameters, contributing road widths, and different frequency storm events.

**This page intentionally left blank**

## **Slope Drain for Road Embankments**

### **WHAT IS ITS PURPOSE?**

Protection of road embankments from erosion where concentrated flows discharge off a road onto a fill slope.

### **WHERE AND HOW IS IT COMMONLY USED?**

- Along roads being constructed.
- To remove excess runoff waters.

### **WHEN SHOULD IT BE INSTALLED?**

- While construction activities are occurring.
- After Grading activities are finished.

### **WHEN SHOULD IT NOT BE INSTALLED?**

- Where no containment or diversion berm exists.

### **WHAT NEEDS TO BE INSPECTED?**

- Are there areas where the earthen berm has been breached?
- Do the sandbags need to be repaired or replaced?
- Has the discharge pipe been secured to the slope?
- Is water flowing around the sandbag diversion berm?
- Is the spacing between pipes correct for the diameter pipe used?

### **WHAT MAINTENANCE ACTIVITIES CAN BE EXPECTED?**

- Repair and replacement of sandbags.
- Repair breached sections of earthen berm.
- Removal of slope drain.

### **EQUATION USED TO CALCULATE THE SPACING OF SLOPE DRAINS**

$$L = 245.8 \times D^{2.5} \div (i \times W)$$

Where  $L$  = Spacing between slope drains (feet)

$D$  = Slope drain pipe diameter (inches)

$i$  = rainfall intensity when the time of concentration is eight minutes (inches/hour)

$W$  = Average width of the road that contributes runoff to the slope drain (feet)



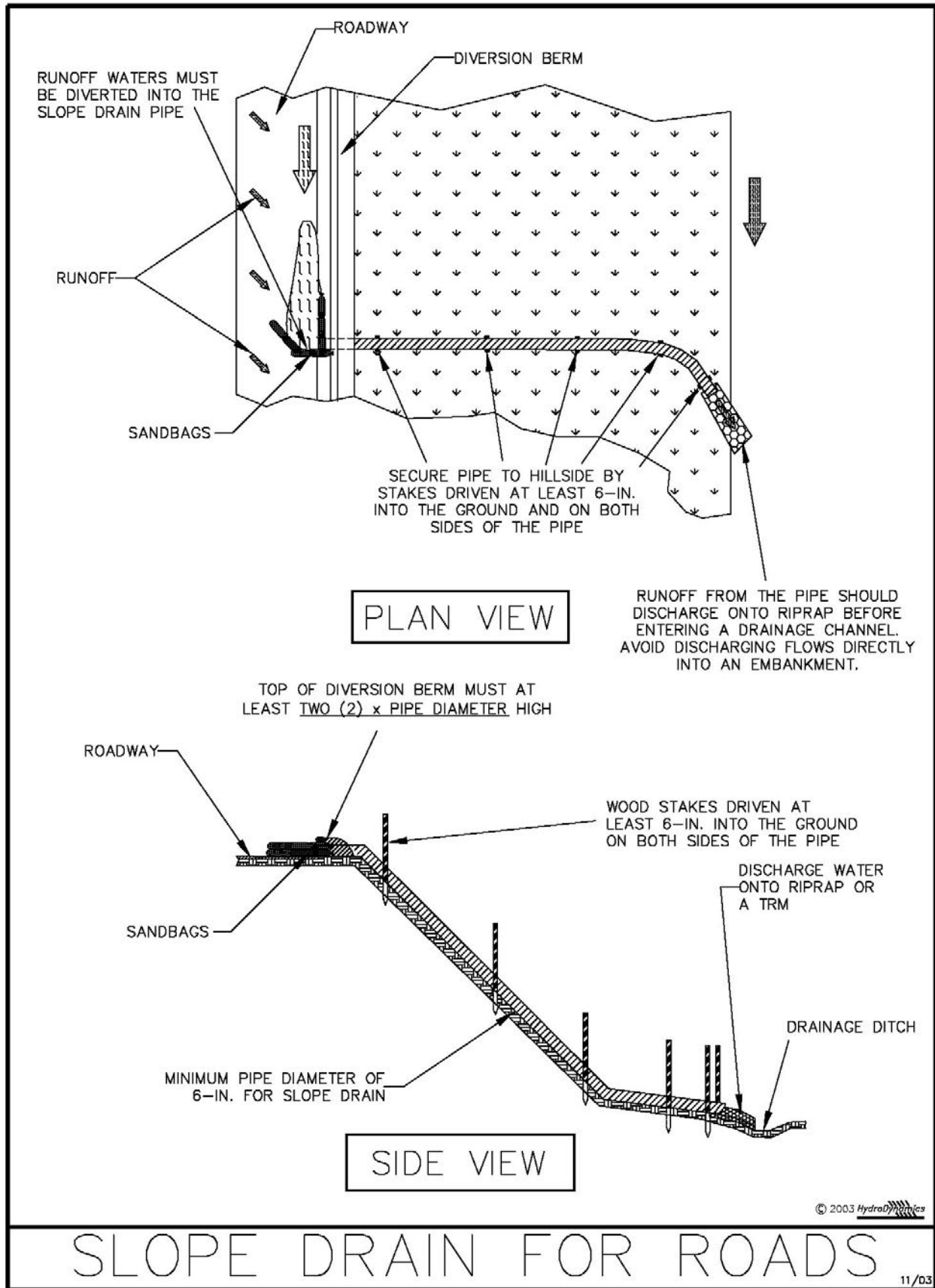
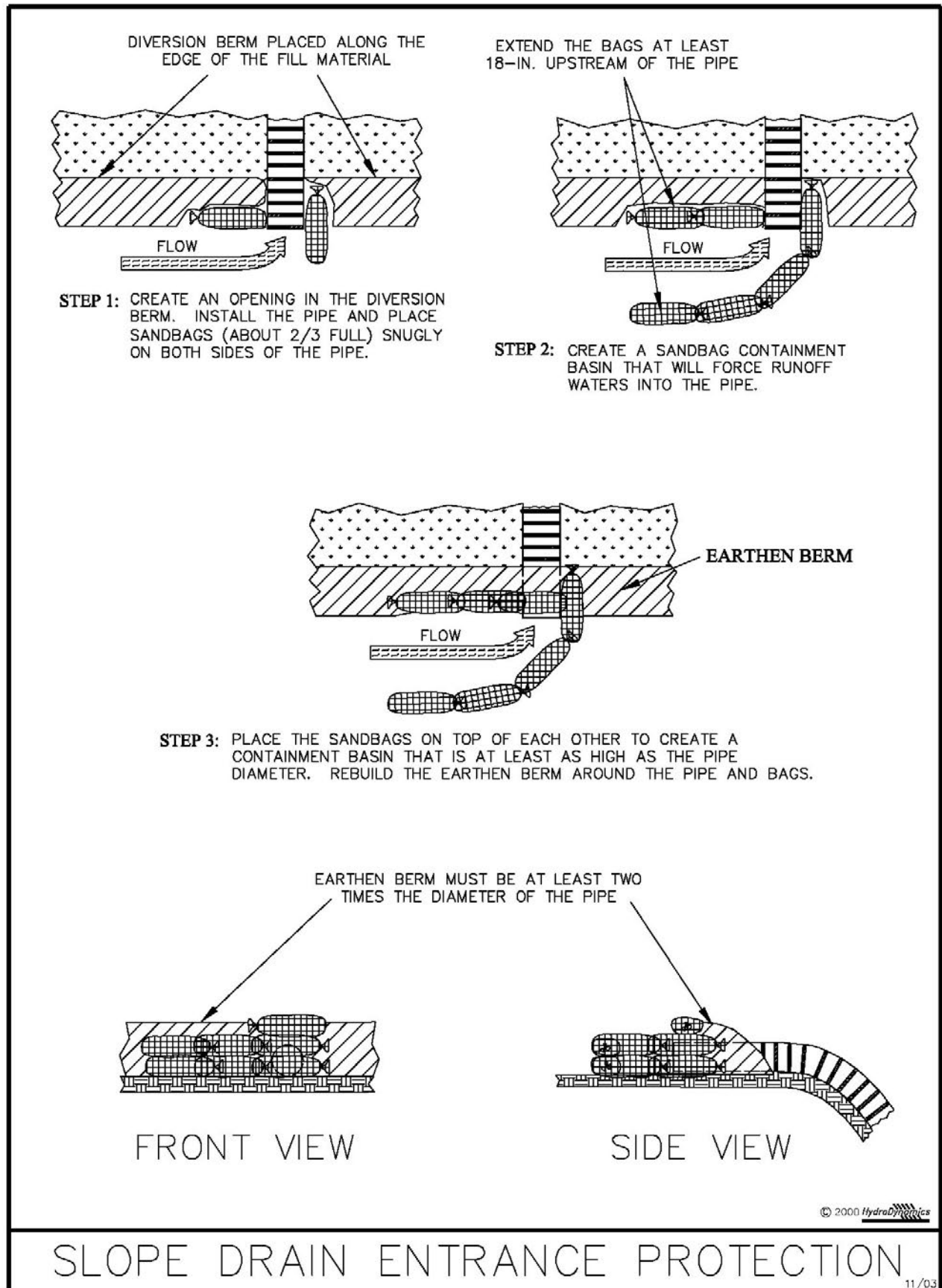

Figure III-6: Installing a Slope Drain for Road Embankments



**Figure III-7: Containment Chamber for a Road Embankment Slope Drain**

Permission is given by HydroDynamics Incorporated to copy and reproduce this detail

### ***Channel Check Structures***

Check structures in drainage channels are one of the more common methods found on construction projects. Many Designers associate the use of these structures as a way to control sediment. In reality, check structures in a drainage channel are examples of sediment containment systems *and* erosion control devices.

Only when *properly installed* will check structures in drainage channels create small SCSs behind the barriers and create erosion protection conditions. As flow velocity becomes sufficiently reduced (usually at the end of a significant runoff event), deposition of suspended particles will occur. Once sedimentation occurs, small "terraces" of deposit material are created behind the barrier (see Figure III-8) and a new channel slope is created that approaches 0.0%. Thus, properly installed check structures in drainage channels for controlling sediment in drainage channels "evolve" into an erosion control method.

### **Spacing of Check Structures**

If check structures are to reduce channel erosion until stabilization occurs, it is important that they be installed in a manner that allows for energy dispersion of the runoff. This is achieved by creating small stilling ponds behind the structures in a manner that prevents erosion of the channel bed (see Figure III-8).

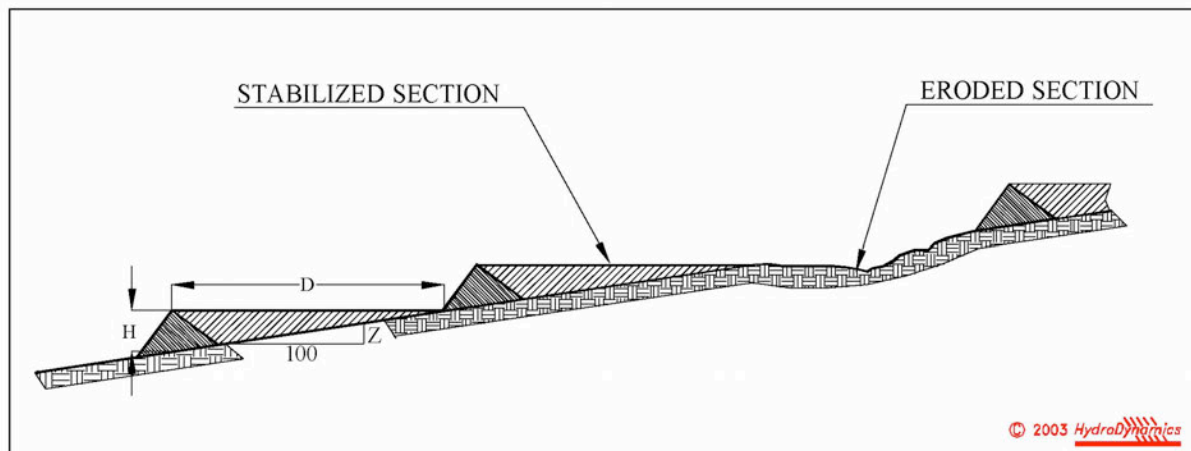

**Figure III-8: Placement of Check Structures for Channel Stability**

As illustrated in Figure III-8, water can pond behind a properly installed barrier check structure. Thus, it is important that the containment structures be able to withstand the large hydraulic force stored water places on the material. It is for this reason, silt fence barriers are *not recommended* as drainage channel check structures unless they are properly installed and supported. Otherwise, these barriers will fail.

Figure III-8 illustrates that placement of barriers along a drainage channel is very important if erosion is to be minimized. Spacing of barriers having different heights is illustrated in Figure III-9.

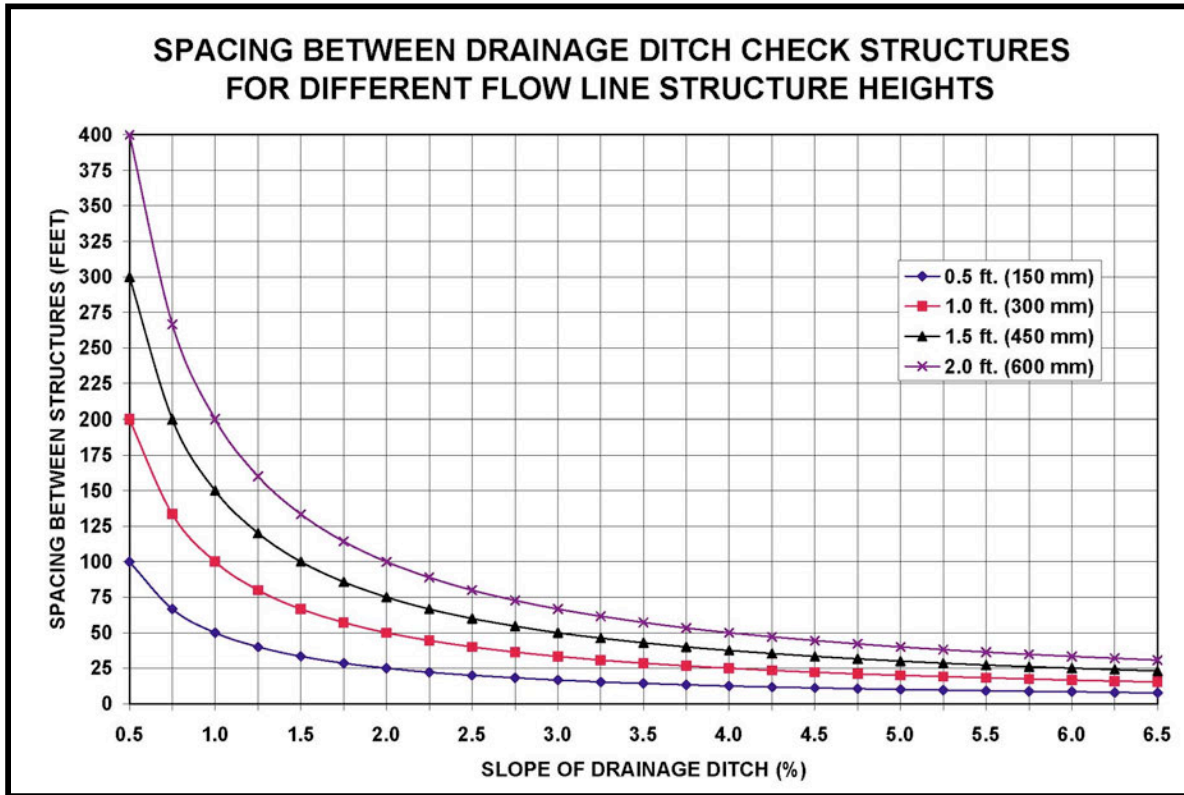

**Figure III-9: Recommended Spacing of Barriers in Drainage Channels When Installed as Erosion Control Measures**

**This page intentionally left blank**

### Geosynthetic Barrier Check Structure

#### **WHAT IS ITS PURPOSE?**

Temporary containment structures to capture sediment and reduce runoff velocities in drainage channels while grading or construction activities occur.

#### **WHERE AND HOW IS IT COMMONLY USED?**

- Within roadside drainage ditches.
- As small sediment traps.

#### **WHEN SHOULD IT BE INSTALLED?**

- While grading or construction activities are occurring.

#### **WHEN SHOULD IT NOT BE INSTALLED?**

- After grading or construction activities are completed.

#### **WHAT NEEDS TO BE INSPECTED?**

- Is the structure properly installed?
- Does runoff flow over the structure?
- Is channel erosion occurring between structures?
- Is there a depression for runoff to flow over?
- Does runoff flow around the structure?
- Is the spacing correct?

#### **WHAT MAINTENANCE ACTIVITIES CAN BE EXPECTED?**

- Repair and replacement of the barrier.
- Repair of eroded channel.
- Removal of sediment.
- Removal of the barrier.

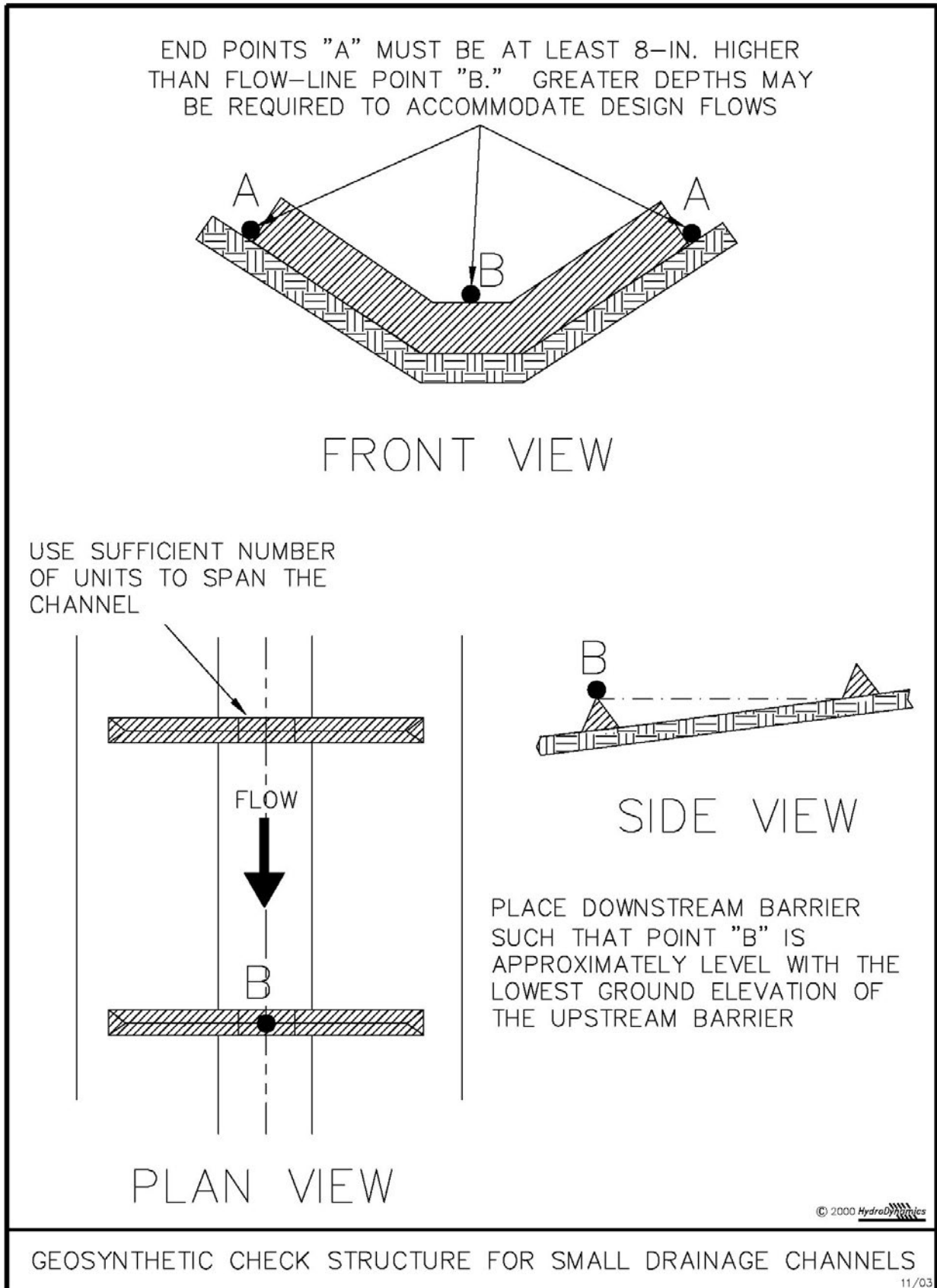

**Figure III-10: Geosynthetic Barrier Check Structure for Small Drainage Ditches**

Permission is given by HydroDynamics Incorporated to copy and reproduce this detail

### Rock Barrier Check Structure

#### **WHAT IS ITS PURPOSE?**

Temporary containment structures to capture sediment and reduce runoff velocities in drainage channels while grading or construction activities occur.

#### **WHERE AND HOW IS IT COMMONLY USED?**

- Within roadside drainage ditches.
- As small sediment traps.

#### **WHEN SHOULD IT BE INSTALLED?**

- While grading or construction activities are occurring.

#### **WHEN SHOULD IT NOT BE INSTALLED?**

- After grading or construction activities are completed and if they are to be the only method used for stabilizing drainage ditches.

#### **WHAT NEEDS TO BE INSPECTED?**

- Are the correct rock diameters used?
- Will water flow over the rocks?
- Is channel erosion occurring between structures?
- Is there a depression for runoff to flow over?
- Will water flow around the rocks?
- Is the spacing correct?

#### **WHAT MAINTENANCE ACTIVITIES CAN BE EXPECTED?**

- Repair and replacement of rock.
- Repair of eroded ground.
- Removal of sediment.
- Removal of rock.



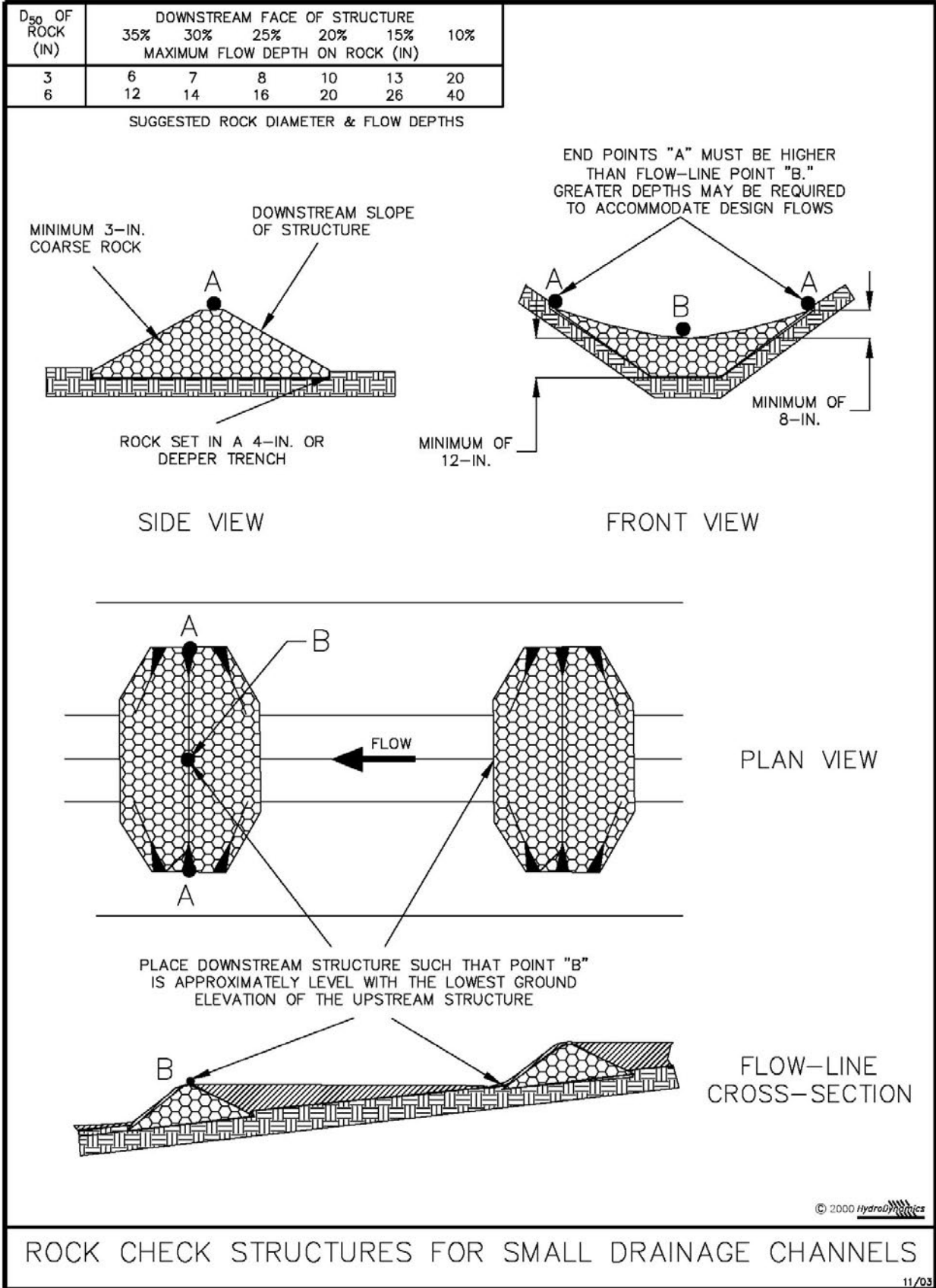

**Figure III-11: Rock Check Structures in Small Drainage Channels**

Permission is given by HydroDynamics Incorporated to copy and reproduce this detail

## **EXAMPLES**

**Channel RECP for a Specific Flow**

What type of RECP is recommended for a triangular channel with 1V:5H side slopes and a channel grade of 1.25% to provide adequate erosion protection against a flow of 24 cfs and to assist with establishment of Type B vegetation?

This type of problem requires using the following equations:

$$V = (1.486 \div n) \times R^{2/3} \times S^{1/2} \quad \tau_{\max} = 62.4 \times Y \times S \quad Q = A \times V$$

It is not possible to use any of the above equations to solve for a specific variable that ensures a correct solution. Instead, an iterative approach on specific variables has to occur.

The one parameter that Designers should know about for drainage channels is flow. In order to calculate flow in a drainage channel, it is necessary to determine cross-sectional area and flow velocity. This can only be accomplished by knowing the depth of flow in the channel when design flows (in this case,  $Q = 24.0$  cfs) occurs.

**Iteration No. 1**

Assume an initial flow depth of 12 inches:

- √ Decide upon a product to use. For this example, assume installation of an excelsior ECB is to occur, which (from Table III-1) has a roughness coefficient  $n = 0.035$ .
- √ Calculate the cross-sectional area, wetted perimeter, and hydraulic radius of the trapezoidal channel for a flow depth  $d = 12$  inches = 1.0 feet.

- From Figure III-3, the cross-sectional area of a triangular channel is calculated by:

$$A = Z \cdot d^2 = 5 \times (1.0)^2 = 5.0 \text{ ft.}^2$$

- From Figure III-3, the wetted perimeter (WP) of a trapezoidal channel is calculated by:

$$WP = 2d \times (Z^2 + 1)^{1/2} = 2 \times 1.0 \times (5^2 + 1)^{1/2} = 10.2 \text{ ft.}$$

The hydraulic radius is calculated by:

$$R = A \div WP = 5.0 \div 10.2 = 0.49 \text{ ft.}$$

- √ Calculate the flow velocity using:

$$V = (1.486 \div n) \times R^{2/3} \times S^{1/2} = (1.486 \div 0.035) \times (0.49)^{2/3} \times (0.0125)^{1/2} = 2.97 \text{ ft./sec.}$$

- √ Calculate the flow rate using:

$$Q = A \times V = 5.0 \times 2.97 = 14.9 \text{ cfs}$$

**STOP: The first iteration for flow did not result in calculating  $Q = 24.0$  cfs. Therefore, a second iteration is required.**

**Iteration No. 2**

Now, assume a flow depth of 1.2 feet and continue using an excelsior ECB having a roughness coefficient  $n = 0.035$ .

Calculate the cross-sectional area, wetted perimeter, and hydraulic radius of the trapezoidal channel for a flow depth  $d = 1.2$  feet.

$$A = Z \cdot d^2 = 5 \times (1.2)^2 = 7.20 \text{ ft.}^2$$

$$WP = 2d \times (Z^2 + 1)^{1/2} = 2 \times 1.2 \times (5^2 + 1)^{1/2} = 12.2 \text{ ft.}$$

$$R = A \div WP = 7.20 \div 12.2 = 0.59 \text{ ft.}$$

✓ Calculate the flow velocity using:

$$V = (1 \div n) \times R^{2/3} \times S^{1/2} = (1.486 \div 0.035) \times (0.59)^{2/3} \times (0.0125)^{1/2} = 3.36 \text{ ft./sec.}$$

✓ Calculate the flow rate using:

$$Q = A \times V = 7.20 \times 3.36 = 24.2 \text{ cfs} \approx 24.0 \text{ cfs} \quad [\text{within acceptable measurement error}]$$

✓ Calculate the maximum shear stress using:

$$\tau_{max} = 62.4 \times Y \times S = 62.4 \times 1.2 \times 0.0125 = 0.94 \text{ lbs./ft.}^2$$

✓ Compare the calculated shear stress and velocity values to those found in Table III-2.

- An excelsior product has a maximum permissible shear stress of 1.44 to 2.00  $\text{lbs./ft.}^2$ , which is greater than 0.94  $\text{lbs./ft.}^2$ .
- An excelsior product has a maximum permissible velocity of 4.9 to 7.9  $\text{ft./sec.}$ , which is greater than 3.36  $\text{ft./sec.}$ .

Therefore, it is possible to use a properly installed excelsior product.

✓ Use Table III-2 to determine if anticipated shear stress values will impact vegetation when flows of 3.36  $\text{ft./sec.}$  occur having a depth of 1.2 feet and no ECB material exists.

- Class B vegetation cannot have shear stress values that exceed 2.09  $\text{lbs./ft.}^2 > 0.94 \text{ lbs./ft.}^2$ .

Therefore, when flows of 24.0  $\text{cfs}$  occur, properly installed excelsior ECB should provide protection against channel erosion until Class B vegetation is established.

Designers are encouraged to evaluate shear stress and velocity for different scenarios. For example, if in the above example the channel slope were increased to 5.0%, then the shear stress would be about 2.6  $\text{lbs./ft.}^2$  with a flow velocity of 7.0  $\text{cfs}$  and a water depth of 10 inches. Only a TRM can be installed in the channel to ensure adequate protection exists.

Finally, values reported in Table III-1 and Table III-2 provides only an estimate of how RECPs will perform. When developing specifications for a TRM or ECB, Designers must always obtain up-to-date shear stress and velocity information from manufacturers for their projects to ensure proper product selection.

**Basin Slope Drain**

A roadway project is to be constructed within a wooded area and on sandy soils. It has been determined that approximately 8.4 acres will discharge offsite flows onto the construction site. What diameter pipe for a slope drain is needed to route offsite flows caused by a 10-year storm event? Assume the offsite basin has an average slope of 2.3% and Time of Concentration of 12 minutes in Zone 3.

*Step 1. Determine the C from Table III-3 following this page:*

$$C = 0.15 \text{ to } 0.20$$

*Step 2. Determine the rainfall intensity in Zone 3 from Figure III-15:*

$$i = 6.8 \text{ inches/hour}$$

*Step 3. Calculate a theoretical pipe diameter from the equation:*

$$D = 4.29 \times Q^{0.50} = 4.29 \times (CiA)^{0.50}$$

$$\text{When } C = 0.15, D = 4.29 \times (0.15 \times 6.8 \times 8.4)^{0.50} = 12.6 \text{ inches}$$

$$\text{When } C = 0.20, D = 4.29 \times (0.20 \times 6.8 \times 8.4)^{0.50} = 14.5 \text{ inches}$$

*Step 4: Determine the diameter pipe to use.*

Unless the Designer is confident that the minimum runoff coefficient is applicable, use the worst case scenario to select a pipe having a readily available diameter. In this situation, it is possible to use a 15-inch diameter pipe---if one can be found. More than likely, an 18-inch diameter pipe will have to be installed.

**Roadway Slope Drain**

The above roadway project will have a section where approximately 160 feet of fill material will exist. The Designer observes from the plan and profile drawings that runoff from about 30 feet of upstream road construction will discharge onto where road fill material exists. In order to minimize damage to the two-lane road fill material, it is decided to install a series of 6-inch diameter slope drains. The first pipe will be installed to capture runoff from the upstream contributing 30 feet of roadway.

If each lane of the road is approximately 16 feet wide, how far apart should the slope drains be placed and what is the height of the containment berm along the edge of the roadway fill material for a 10-year storm event?

*Step 1. Determine the intensity of rainfall occurring in Zone 3 when the time of concentration is 8 minutes:*

$$i = 7.5 \text{ inches/hour}$$

*Step 2. Calculate the distance between each slope drain:*

$$L = (245.8 \times D^{2.5}) \div (i \times W) = (245.8 \times 6^{2.5}) \div (7.5 \times 16 \times 2) = 90 \text{ feet}$$

*Step 3: Calculate the height of the containment berm:*

$$H = 2 \times \text{pipe diameter} = 2 \times 6 \text{ inches} = 12 \text{ inches} = 1.0 \text{ feet}$$

Note: Since there are 160 linear feet of fill material, placing the slope drains about 90 feet apart will be adequate to convey road runoff via 6-inch diameter pipes.

**Table III-3. Runoff Coefficients for the Rational Method (from FDOT, 1987)**

SLOPE LAND USE		SANDY SOILS		CLAYEY SOILS	
		MIN	MAX	MIN	MAX
Flat (0-2%)	Woodlands	0.10	0.15	0.15	0.20
	Pasture, grass, and farmland <sup>b</sup>	0.15	0.20	0.20	0.25
	Rooftops and pavement	0.95	0.95	0.95	0.95
	Pervious pavements <sup>c</sup>	0.75	0.95	0.90	0.95
	SFR: 1/2-acre lots and larger	0.30	0.35	0.35	0.45
	Smaller lots	0.35	0.45	0.40	0.50
	Duplexes	0.35	0.45	0.40	0.50
	MFR: Apartments, townhouses, etc.	0.45	0.60	0.50	0.70
	Commercial and Industrial	0.50	0.95	0.50	0.95
Rolling (2-7%)	Woodlands	0.15	0.20	0.20	0.25
	Pasture, grass, and farmland <sup>b</sup>	0.20	0.25	0.25	0.30
	Rooftops and pavement	0.95	0.95	0.95	0.95
	Pervious pavements <sup>c</sup>	0.80	0.95	0.90	0.95
	SFR: 1/2-acre lots and larger	0.35	0.50	0.40	0.55
	Smaller lots	0.40	0.55	0.45	0.60
	Duplexes	0.40	0.55	0.45	0.60
	MFR: Apartments, townhouses, etc.	0.50	0.70	0.60	0.80
	Commercial and Industrial	0.50	0.95	0.60	0.95
Steep (7%+)	Woodlands	0.20	0.25	0.25	0.30
	Pasture, grass, and farmland <sup>b</sup>	0.25	0.35	0.30	0.40
	Rooftops and pavement	0.95	0.95	0.95	0.95
	Pervious pavements <sup>c</sup>	0.85	0.95	0.90	0.95
	SFR: 1/2-acre lots and larger	0.40	0.55	0.50	0.65
	Smaller lots	0.45	0.60	0.55	0.70
	Duplexes	0.45	0.60	0.55	0.70
	MFR: Apartments, townhouses, etc.	0.60	0.75	0.65	0.85
	Commercial and Industrial	0.60	0.95	0.65	0.95

Source: FDOT (1987)

<sup>a</sup>Weighted coefficient based on percentage of impervious surfaces and green areas must be selected for each site.

<sup>b</sup>Coefficients assume good ground cover and conservation treatment.

<sup>c</sup>Depends on depth and degree of permeability of underlying strata.

NOTE: SFR = Single Family Residential; MFR = Multi-Family Residential

For recurrence intervals longer than ten years, the indicated runoff coefficients should be increased, assuming that nearly all of the rainfall in excess of that expected from the ten year recurrence interval rainfall will become runoff and should be accommodated by an increased runoff coefficient.

The runoff coefficients indicated for different soil conditions reflect runoff behavior shortly after initial construction. With the passage of time, the runoff behavior shortly after initial construction. With the passage of time, the runoff behavior in sandy areas will tend to approach that in heavy soil areas. If the designer's interest is long term, the reduced response indicated for sandy soils should be disregarded.

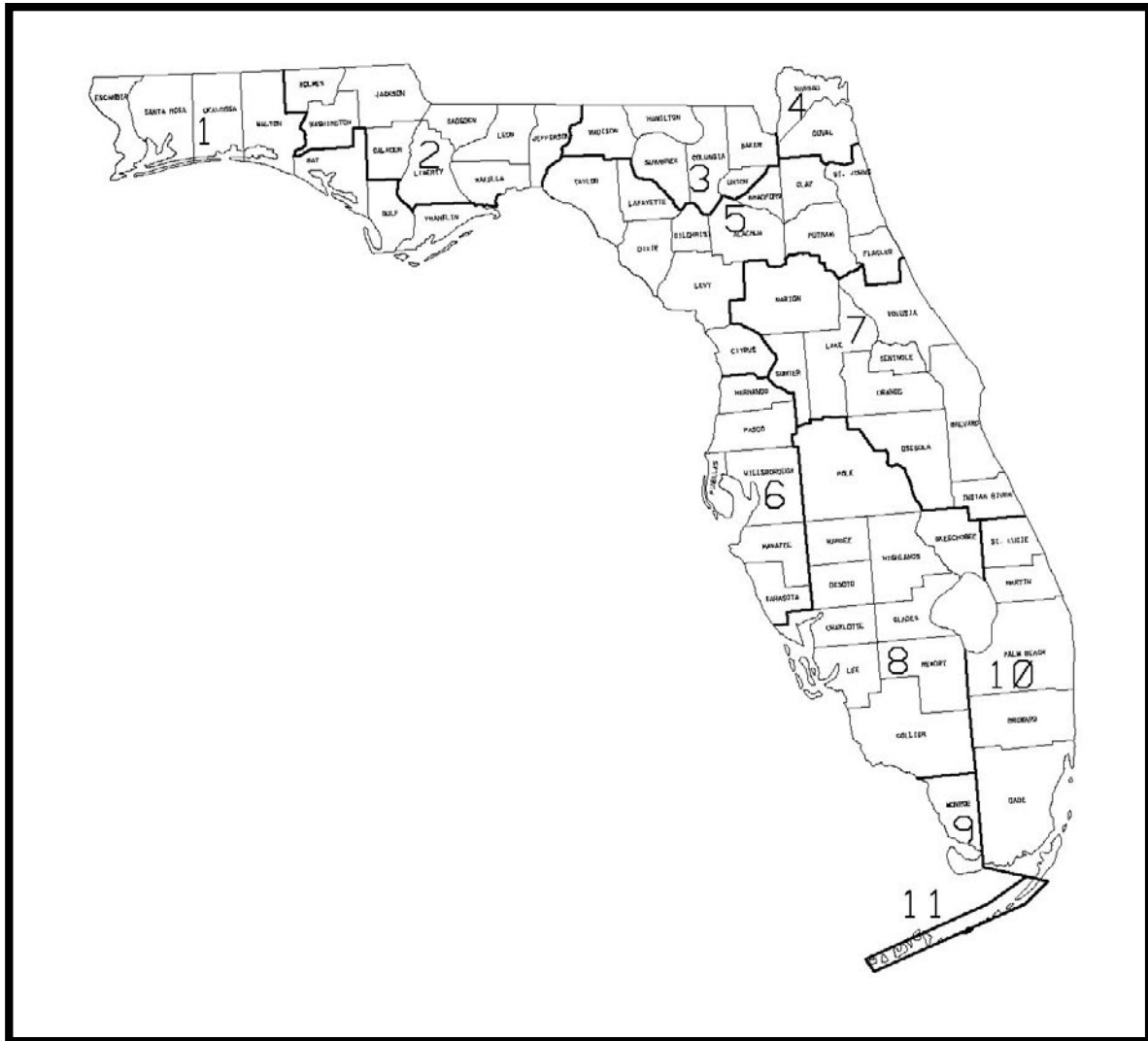

**Figure III-12. Zones for Precipitation Intensity Duration Frequency Curves as Developed by the FDOT (2001)**

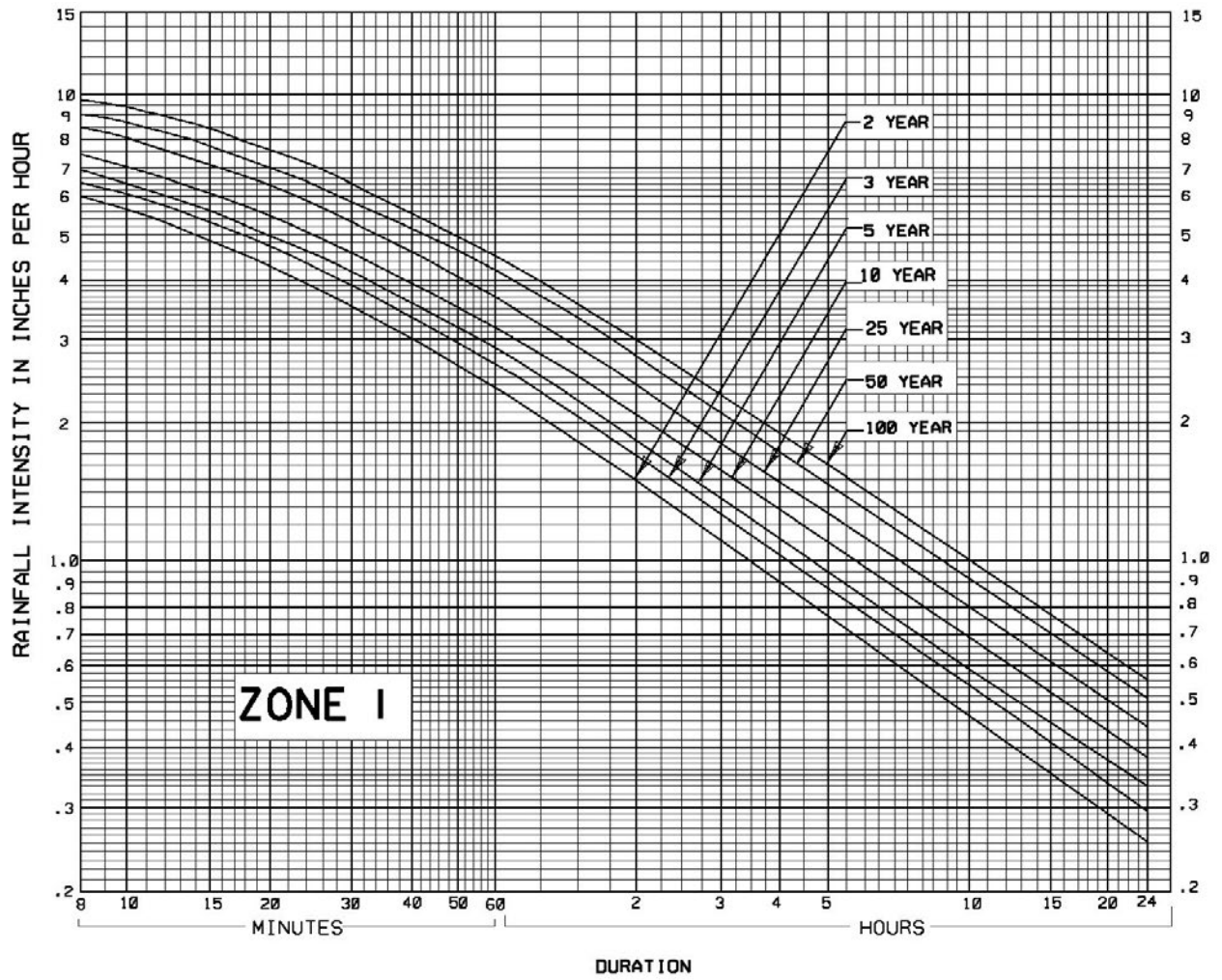

Figure III-13. Rainfall Intensity Duration Frequency Curve for Zone 1 (FDOT, 2001)



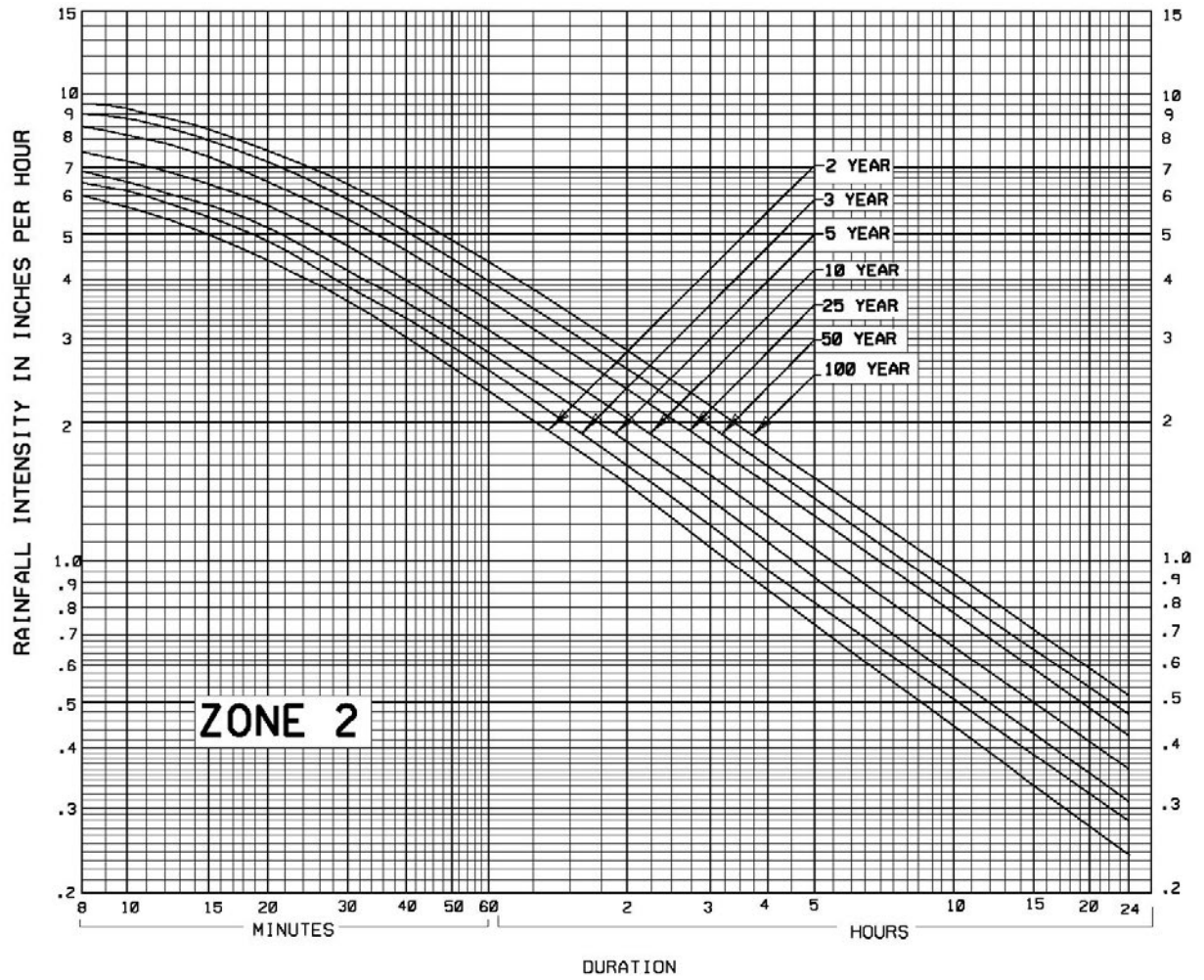

Figure III-14. Rainfall Intensity Duration Frequency Curve for Zone 2 (FDOT, 2001)

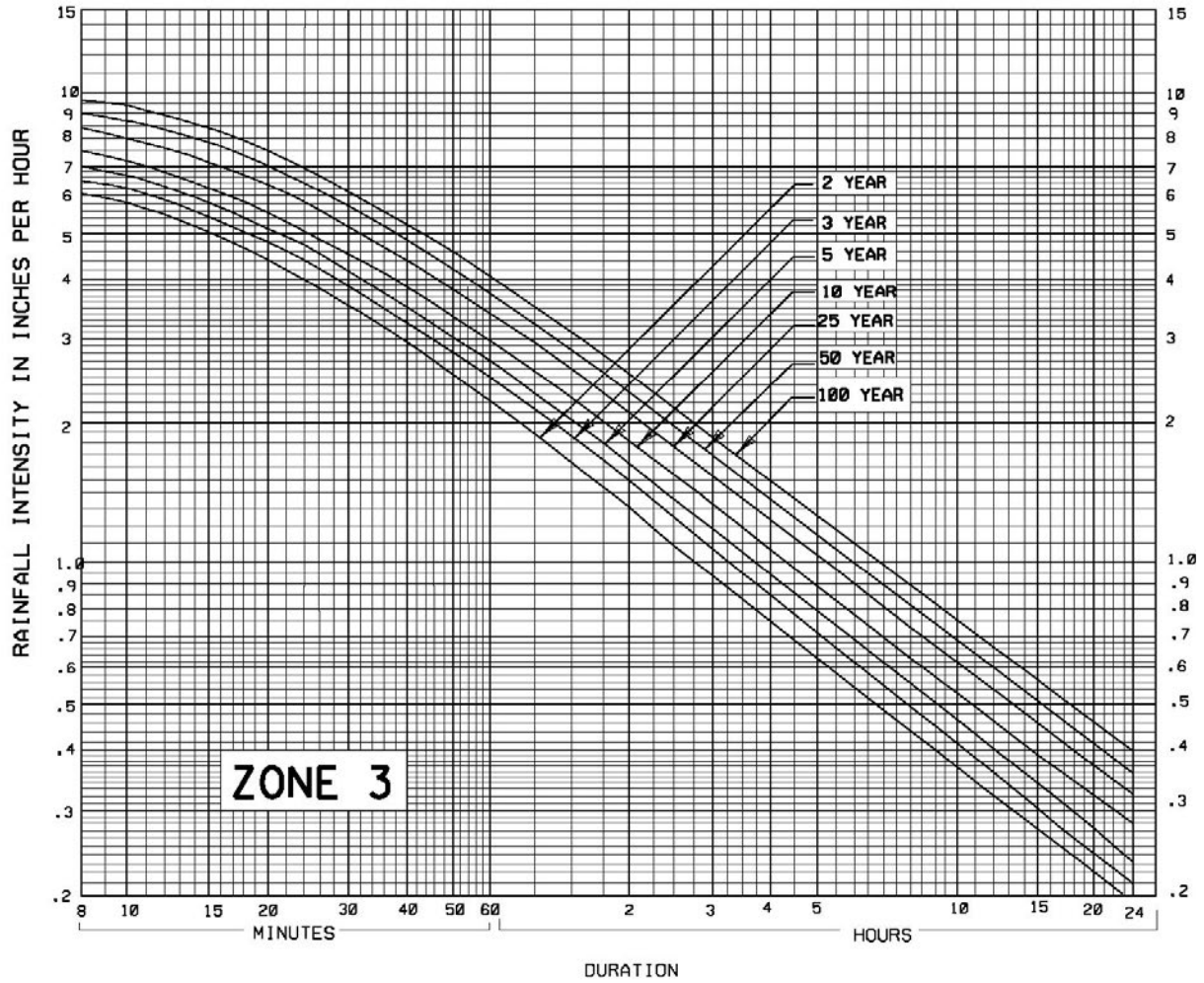

Figure III-15. Rainfall Intensity Duration Frequency Curve for Zone 3 (FDOT, 2001)

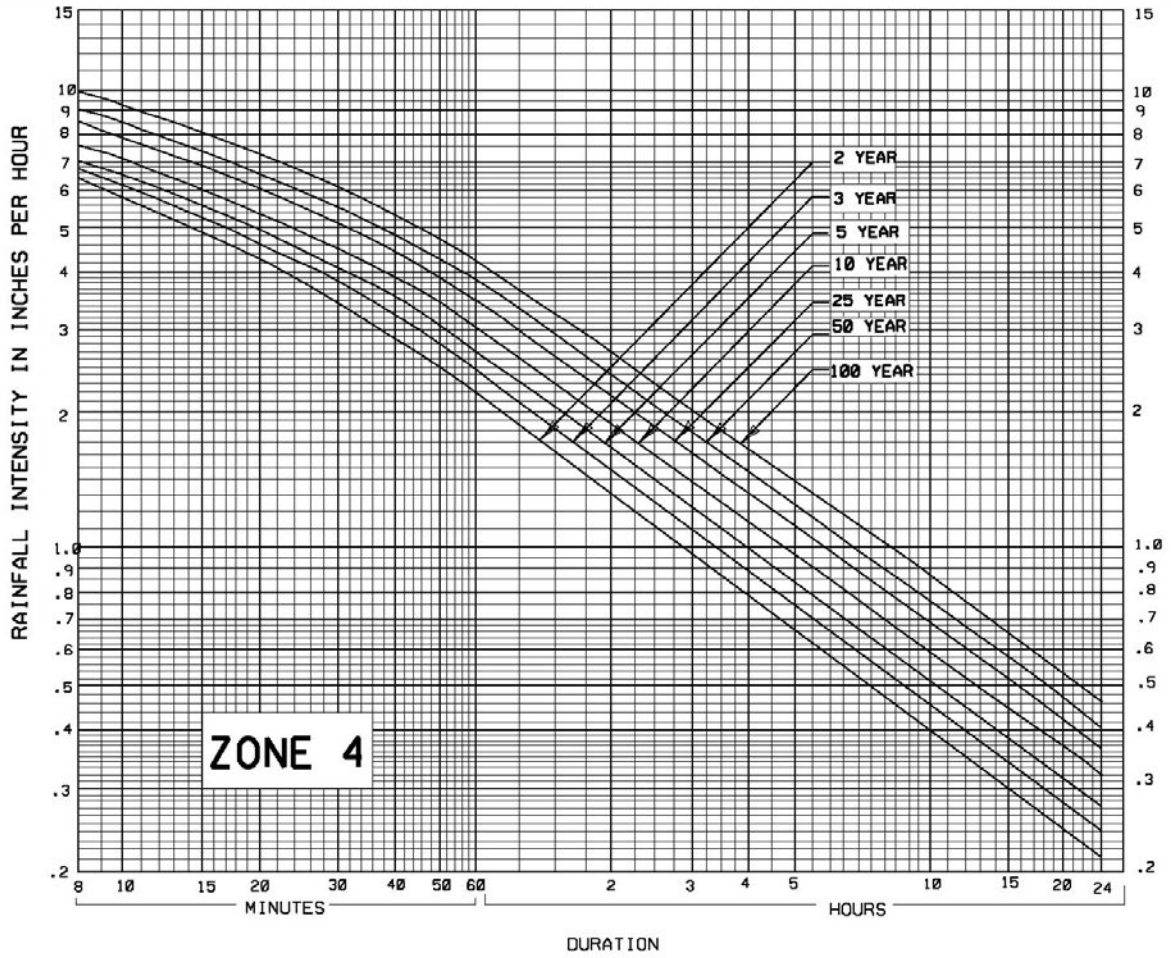

Figure III-16. Rainfall Intensity Duration Frequency Curve for Zone 4 (FDOT, 2001)

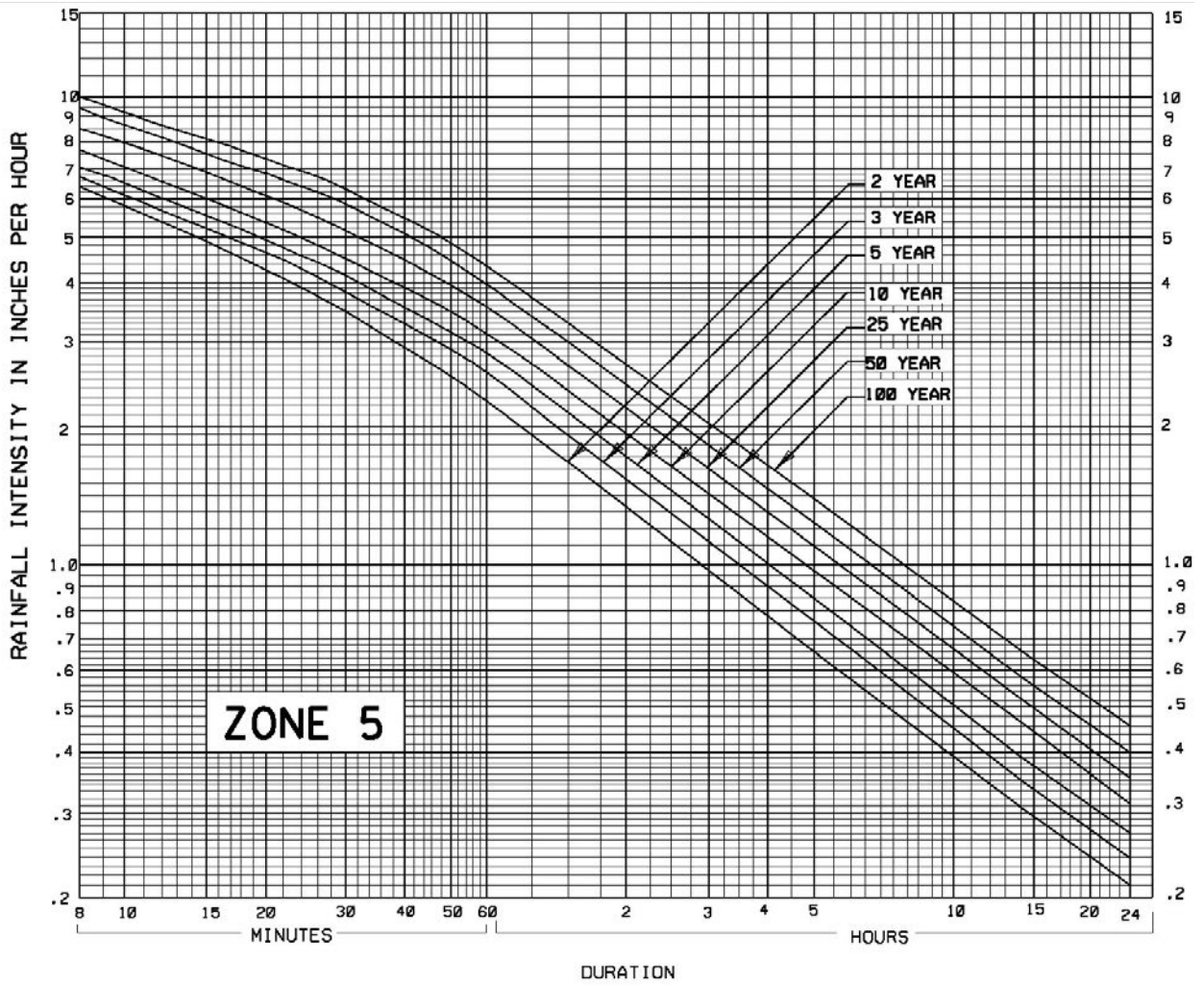

Figure III-17. Rainfall Intensity Duration Frequency Curve for Zone 5 (FDOT, 2001)

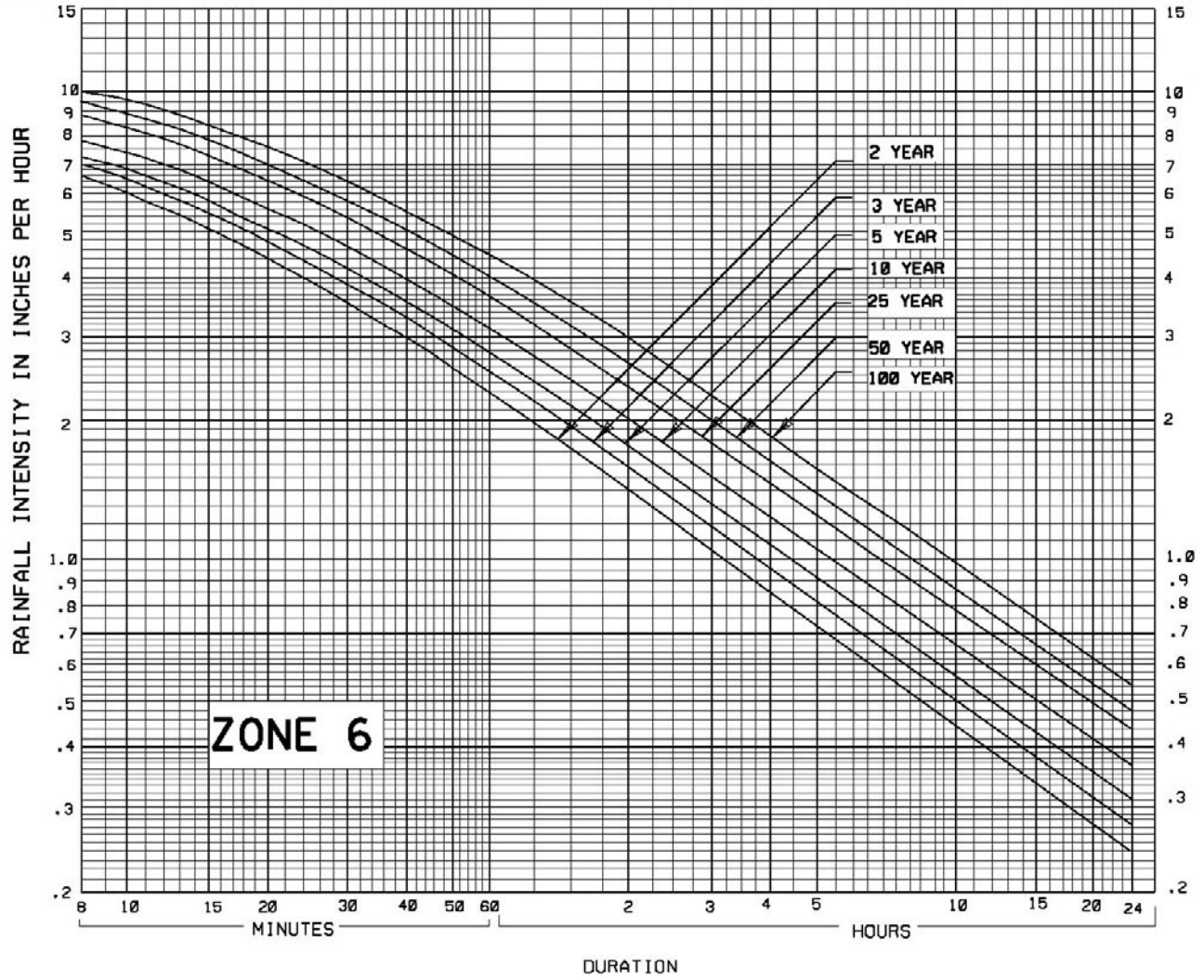

Figure III-18. Rainfall Intensity Duration Frequency Curve for Zone 6 (FDOT, 2001)

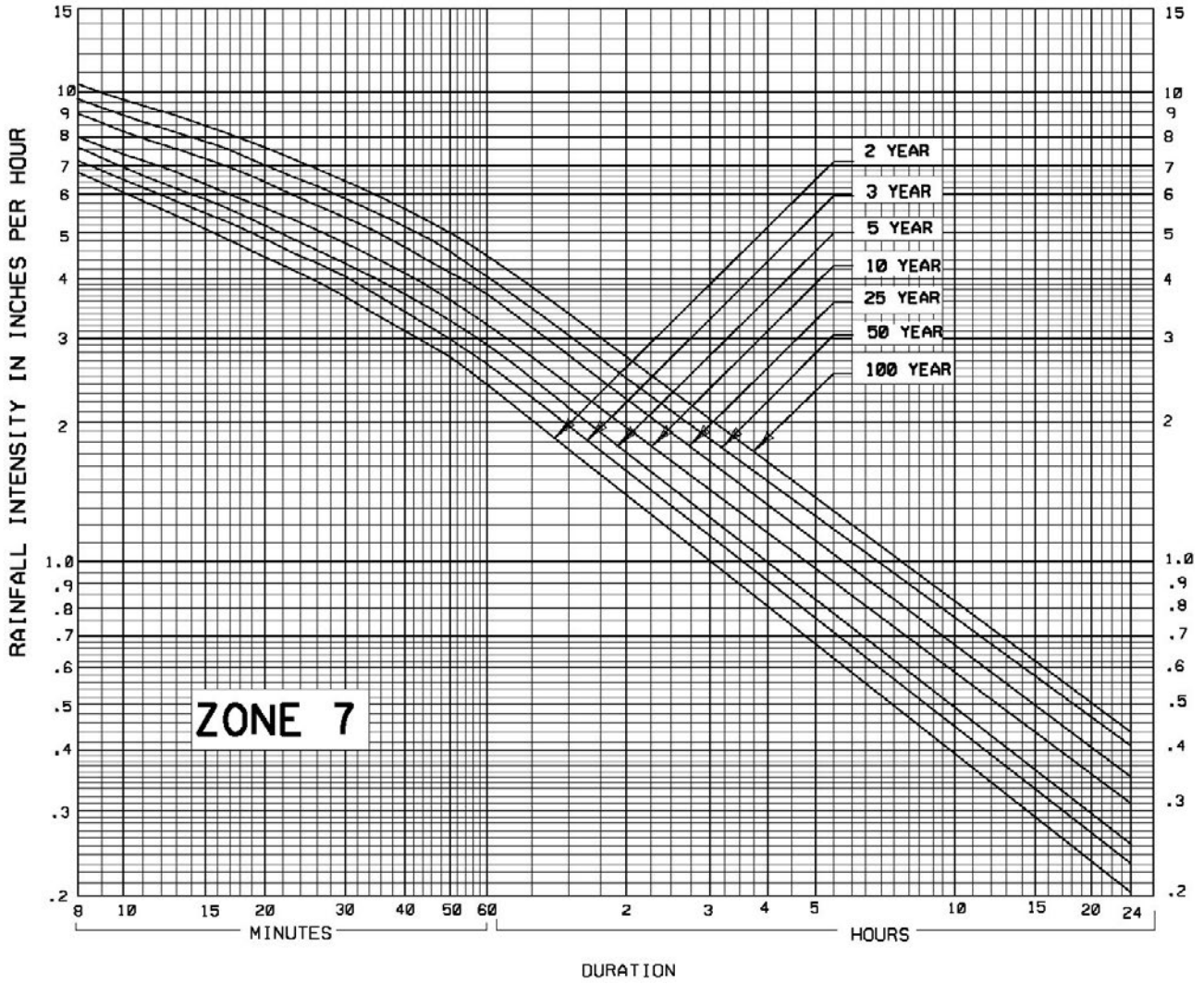

Figure III-19. Rainfall Intensity Duration Frequency Curve for Zone 7 (FDOT, 2001)

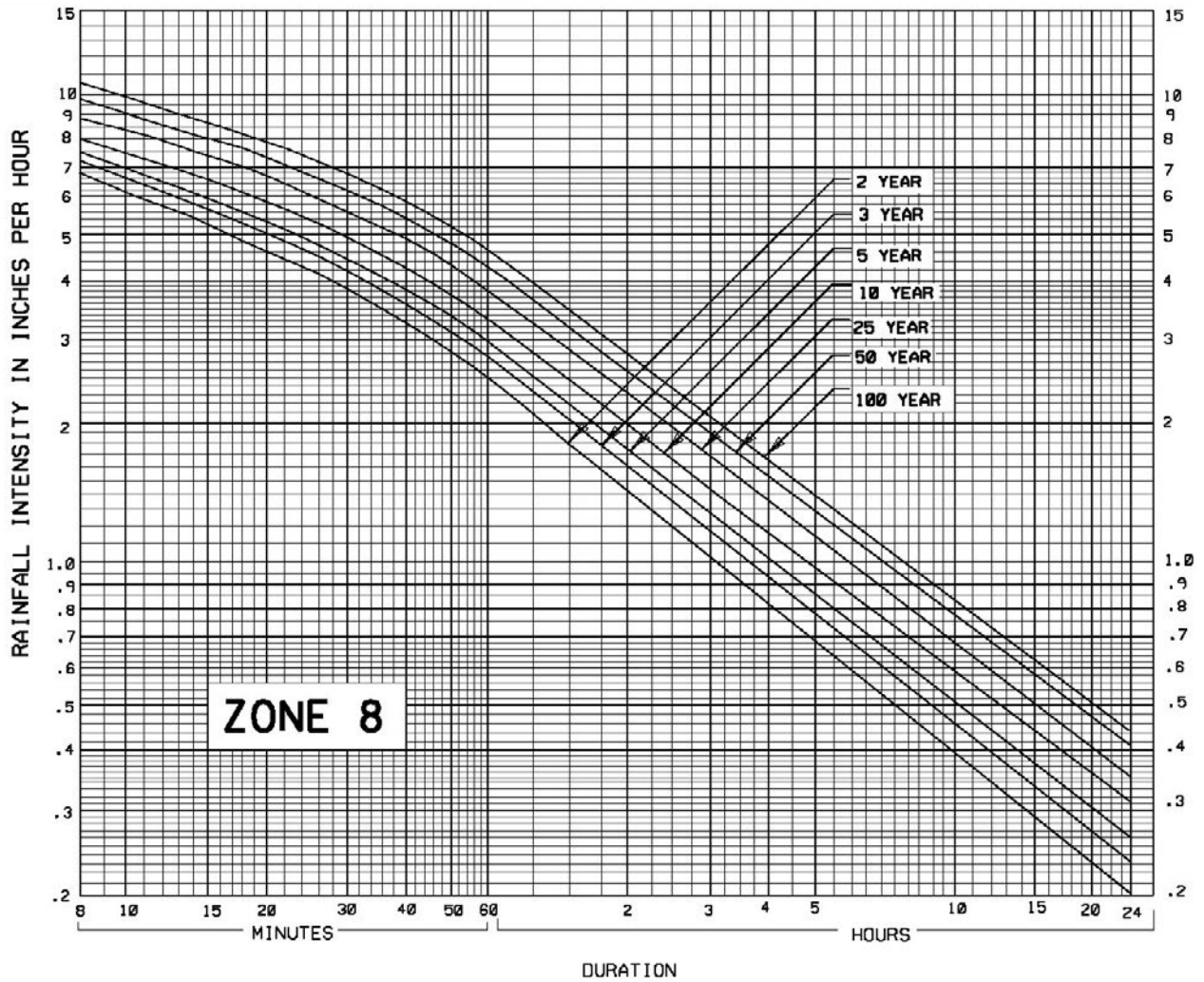

Figure III-20. Rainfall Intensity Duration Frequency Curve for Zone 8 (FDOT, 2001)

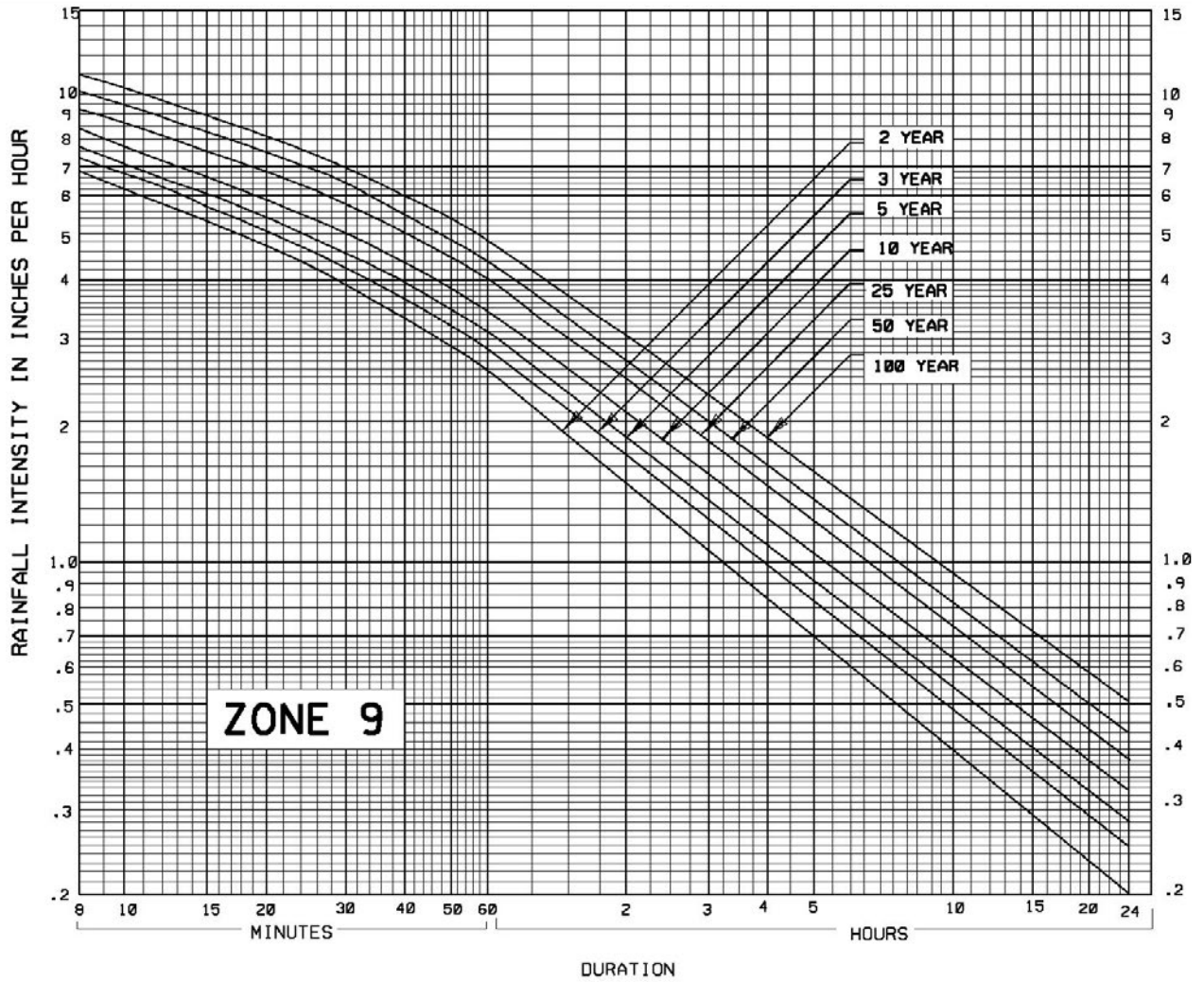

Figure III-21. Rainfall Intensity Duration Frequency Curve for Zone 9 (FDOT, 2001)



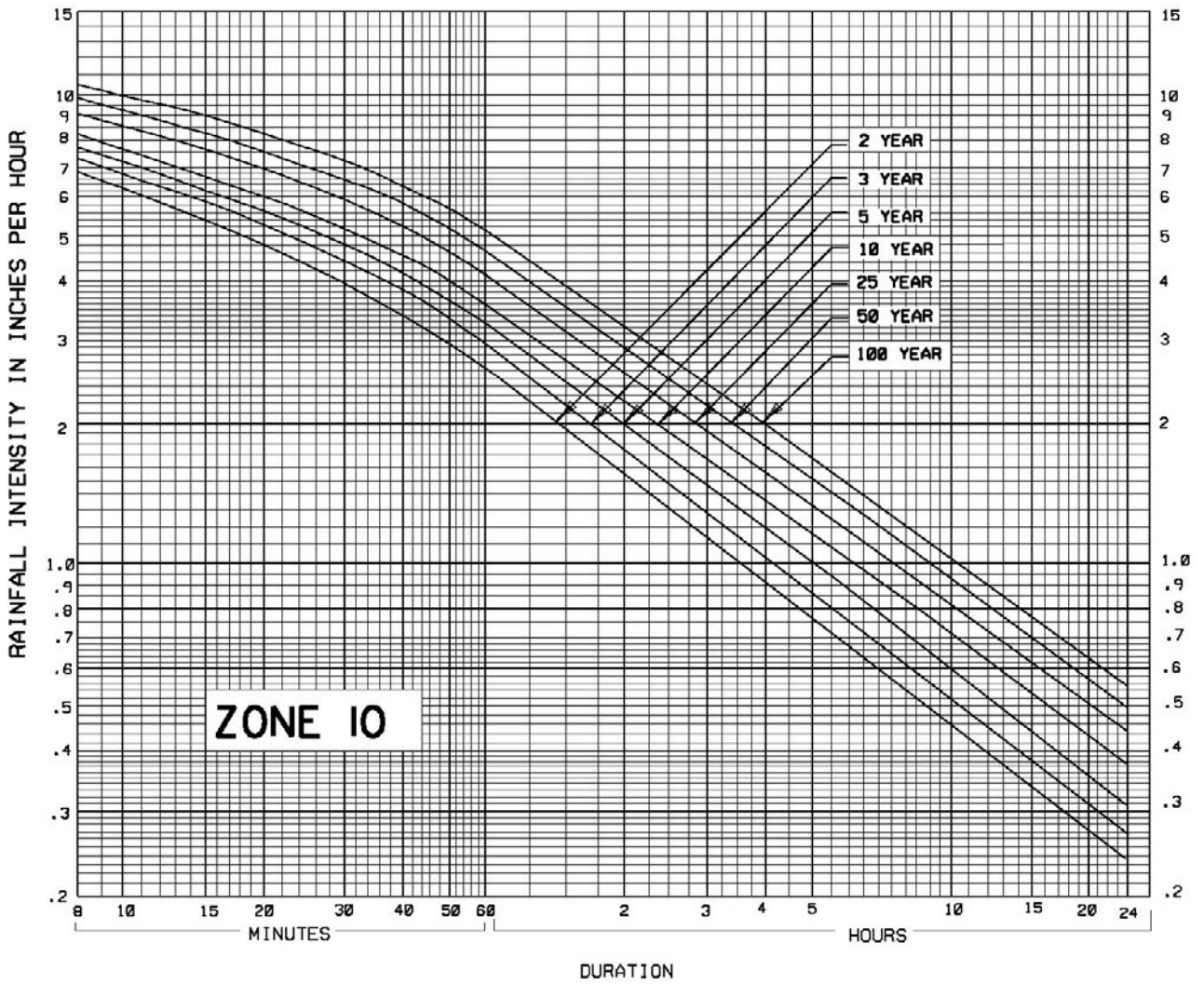

Figure III-22. Rainfall Intensity Duration Frequency Curve for Zone 10 (FDOT, 2001)

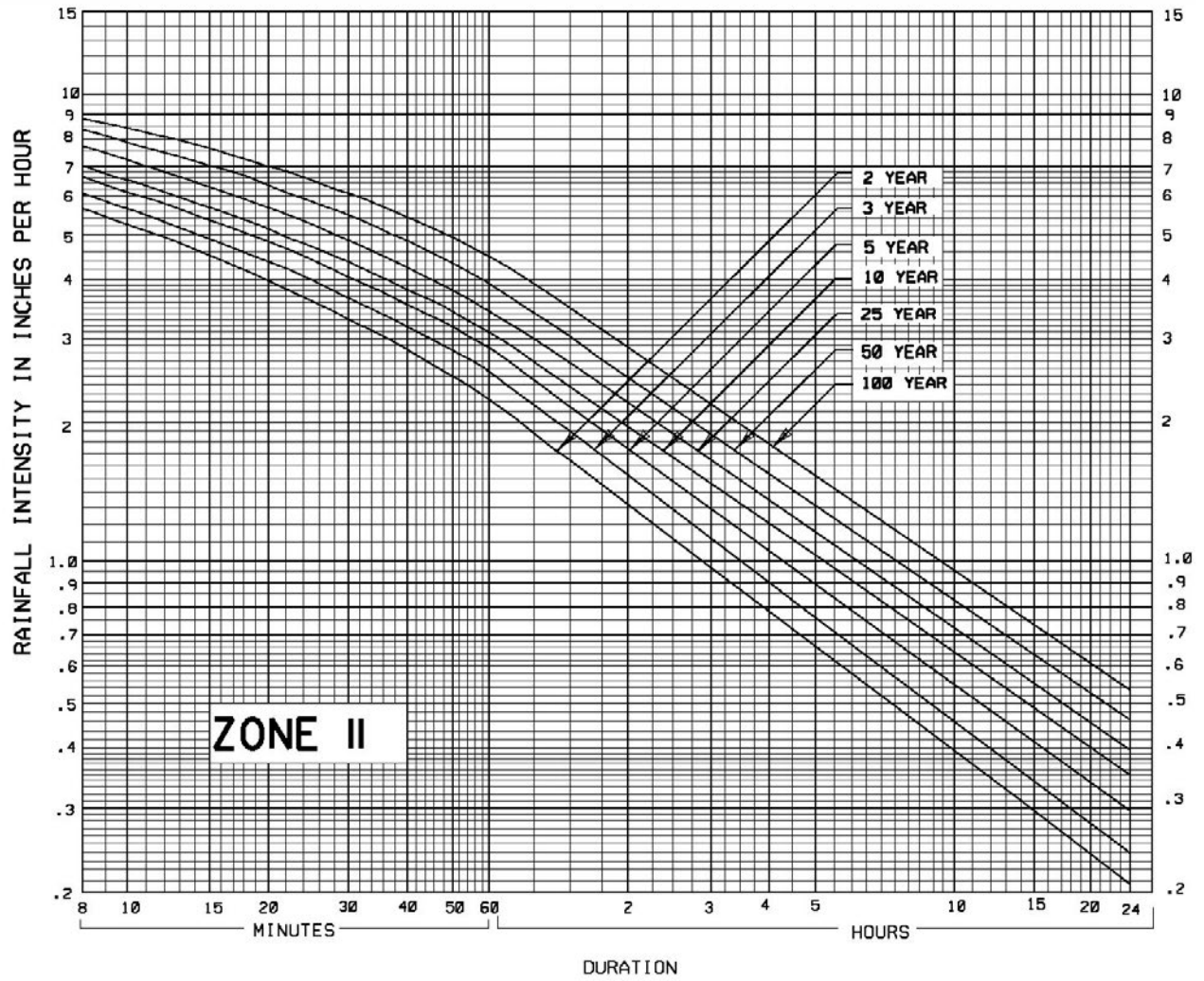

Figure III-23. Rainfall Intensity Duration Frequency Curve for Zone 11 (FDOT, 2001)

**SECTION IV**  
**SEDIMENT CONTAINMENT SYSTEMS**

## Table of Contents

<b>INTRODUCTION.....</b>	<b>1</b>
DESIGNING SCSS INTO AN E&SC DRAWING.....	1
DEFINING SEDIMENT CONTAINMENT SYSTEMS .....	2
EFFECTIVENESS OF SEDIMENT CONTAINMENT SYSTEMS .....	4
SEDIMENT CONTAINMENT SYSTEM OUTLET STRUCTURES.....	9
<i>Surface Skimmers</i> .....	9
<i>Perforated Riser Pipes</i> .....	9
<b>DEWATERING ACTIVITIES.....</b>	<b>9</b>
TYPES OF DEWATERING METHODS .....	9
<i>Rim ditching</i> .....	9
<i>Sock pipe/Horizontal wells</i> .....	10
<i>Well-point systems</i> .....	10
TURBIDITY MONITORING FOR OFF-SITE DISCHARGE.....	10
USING SCSS FOR DEWATERING.....	10
INCREASING THE EFFICIENCY OF A SCS.....	10
<i>Pre-Sedimentation Basins</i> .....	20
<i>Barriers for Pre-Sedimentation Basins</i> .....	21
USE OF POLYMERS OR ALUM .....	36
<i>Steps for Introducing Polymers into Runoff Waters</i> .....	36
<i>Sediment Retention Barriers Using Polymers</i> .....	37
<i>Using Alum to Remove Sediment from Runoff Waters</i> .....	38
<b>EXAMPLES .....</b>	<b>39</b>
SCS EFFECTIVENESS OF AN EXISTING POND.....	40
SIZING A DEWATERING SCS.....	42
BUILDER PRE-SEDIMENTATION BASIN.....	43
LINEAR ROAD PRE-SEDIMENTATION BASIN .....	43
 <u>BMP Summary Sheets for Sediment Containment Systems</u>	
Sediment Containment System Internal Barrier and Weir.....	<b>10</b>
Sediment Containment System Surface Skimmer.....	<b>14</b>
Sediment Containment System Riser Pipe Outlet Structure.....	<b>16</b>
Sediment Containment System Rock Berm Outlet Structure .....	<b>26</b>
Sediment Containment System Single Chamber .....	<b>28</b>

Sediment Containment System Double Chamber ..... **30**  
Sediment Containment System Barrier for Culvert..... **32**  
Sediment Containment System Filter Bag ..... **34**

## Table of Figures

FIGURE IV-1:	APPARENT EFFECTIVENESS GRAPH (FIFIELD, 2004) .....	7
FIGURE IV-2:	PEG CHART FOR SEDIMENT CONTAINMENT SYSTEMS (FIFIELD, 2004) .....	8
FIGURE IV-3:	ILLUSTRATION OF A SCS INTERNAL SILT FENCE BARRIER AND WEIR.....	13
FIGURE IV-4:	ILLUSTRATION OF A SCS SURFACE SKIMMER.....	15
FIGURE IV-5:	ILLUSTRATION OF A SCS RISER PIPE OUTLET STRUCTURE.....	19
FIGURE IV-6:	CONCEPTUAL PRE-SEDIMENTATION (A.K.A. FOREBAY) BASINS (NO SCALE) .....	20
FIGURE IV-7:	HYDROLOGIC TYPE A SOILS LOADING RATIO GRAPH.....	22
FIGURE IV-8:	HYDROLOGIC TYPE B SOILS LOADING RATIO GRAPH.....	23
FIGURE IV-9:	HYDROLOGIC TYPE C SOILS LOADING RATIO GRAPH .....	24
FIGURE IV-10:	HYDROLOGIC TYPE D SOILS LOADING RATIO GRAPH .....	25
FIGURE IV-11:	ILLUSTRATION OF A SCS ROCK BERM OUTLET STRUCTURE .....	27
FIGURE IV-12:	ILLUSTRATION OF A SINGLE CHAMBER SCS .....	29
FIGURE IV-13:	ILLUSTRATION OF A DOUBLE CHAMBER SCS.....	31
FIGURE IV-14:	ILLUSTRATION OF A ROCK BARRIER STRUCTURE FOR CULVERTS.....	33
FIGURE IV-15:	ILLUSTRATION OF A SEDIMENT CONTAINMENT SYSTEM FILTER BAG.....	35
TABLE IV-1:	SEDIMENT CONTAINMENT SYSTEM CLASSIFICATIONS .....	3
TABLE IV-2:	MINIMUM PARAMETERS FOR SEDIMENT CONTAINMENT SYSTEMS (FIFIELD, 2004).	5
TABLE IV-3:	ESTIMATED SETTLING VELOCITIES FOR SUSPENDED PARTICLES (SPECIFIC GRAVITY = 2.65) IN WATER AT DIFFERENT TEMPERATURES AS CALCULATED BY STOKES' LAW.....	6

## INTRODUCTION

Sediment containment systems (SCSs) are barriers having hydraulic controls that function by modifying the storm-runoff hydrograph and slowing water velocities. This allows for the deposition of larger suspended particles by gravity. Some of the more common names for these structures are *sediment basins*, *sediment ponds*, and *sediment traps*.

The only structural BMPs that can effectively remove sediment when large storm water discharges occur from active construction sites are strategically placed SCSs. Since erosion control methods cannot always be implemented in a timely manner during the construction process, Designers must include properly designed SCSs as an integral part of their E&SC plan. More importantly, the development of effective SCSs must be based upon capturing design size particles.

The role of any SCS is to create conditions for sedimentation; that is, to allow for the settlement of suspended soil particles found in runoff waters. When soil-particle transport mechanisms, such as water or wind, move at a slow rate, particles can settle out of suspension due to gravity. Deposition of sediment in an SCS is dependent upon many different parameters, including:

- Mass of the suspended particles falling through contained waters
- Surface area and containment storage volume for incoming runoff waters
- Sufficient flow path lengths within the containment system
- Uniform flow zones within the storage volume
- Discharge rates of water out of the containment system

### ***Designing SCSs into an E&SC Drawing***

While construction sites present dynamic conditions, Designers can prepare for worse case scenarios by assuming the following on construction activities for lands that discharge into a SCS:

1. Land development activities result in 100% bare ground conditions.
  - a) During the initial phase of over lot grading, temporary retention structures may be able to capture all contributing runoff waters. The EPA requires these containment volumes capture runoff resulting from a 2-year, 24-hour storm event when 10 acres or more of land is disturbed. *The FDEP requires a minimum of 3,600 cubic feet of containment volume when 10 acres or more of land is disturbed.*
    - i. Detention/retention design volumes usually exceed what is needed to capture runoff resulting from a 2-year, 24-hour storm event.
  - b) The amount of bare ground will begin to decrease as installation of erosion control measures and pavement occurs.
  - c) Once an outlet structure is installed, treatment of inflows and discharges may need to occur.
  - d) Once a storm sewer system is installed and runoff discharges into a SCS, then treatment of inflows needs to occur.

2. Constructing vertical/big box structures results in less than 100% bare ground conditions tributary to an SCS as the building process occurs.
  - a) Install and maintain effective SCSs for vertical/big box construction activities until at least 80% full build out conditions exist.
  - b) When the developer's disturbed lands are totally re-vegetated, then only minimal treatment of runoff waters into the SCS may be required. However:
    - i. Vertical/big box construction activities will destroy nearly all pre-existing vegetation.
    - ii. The amount of vertical/big box disturbed lands will vary depending upon the buildings under construction, installation of landscaping material, installation of walkways and driveways, pavement of parking lots, and so forth.
    - iii. Often, development of strategically placed pre-sedimentation (a.k.a. forebay) basins will minimize vertical/big box construction impacts to downstream water bodies (i.e. ponds, canals, etc.).
    - iv. If the developer's land is not re-vegetated, then detention/retention ponds will intercept all sediment-laden runoff waters.
      - (1) Sealing of pond bottoms may occur for untreated inflow waters.
      - (2) Sediment-laden waters may discharge from the pond.
      - (3) Large pre-sedimentation basins may be required.
3. Linear projects will result in 100% bare ground conditions that can be tributary to a SCS.
  - a) During the initial phase of over lot grading, temporary SCSs can be developed and strategically placed to capture contributing runoff waters.
    - i. If installation of outlet structures occurs, treatment of discharge waters (e.g. adding a polymer, ensuring slow release rates, etc.) may need to occur.
    - ii. Development of strategically placed pre-sedimentation basins can minimize linear construction impacts to downstream water bodies (i.e. ponds, canals, etc.).
  - b) The amount of bare ground conditions will decrease as installation of erosion control measures and pavement occurs.
  - c) Once a storm sewer system is installed:
    - i. Treatment of inflows into a containment system is advisable, if waters are released from the SCS.
    - ii. Treatment of outflows is advisable when there is direct discharge into a water body or sensitive area.

### ***Defining Sediment Containment Systems***

When capturing all runoff waters, efficiency of the containment system is 100%. However, the feasibility of *retaining* all runoff waters throughout the life of a construction site (i.e. retention) may be difficult for most sites. Instead of trying to retain all runoff waters, a containment system should detain an adequate volume of runoff long enough to capture suspended "design size" particles. These systems are best represented by detention facilities.

Theoretically, design size particles can have any diameter. However, limitations will exist for design size particles depending upon whether the sediment consists of sandy or clayey materials.



Designers need to select a design size particle that represents the largest percentage of the inflow sediments.

If detention of runoff from construction sites is to be effective in removing suspended particles, contained waters must remain long enough for deposition of suspended particles within the system to occur. This is not a simple task to achieve since suspended particles fall at different rates depending upon their mass. Since outflow from the system will occur, 100% reduction of all incoming suspended particles will not be possible without the addition of polymers.

It is suggested that SCSs be developed based upon design size particles to be removed from inflow waters. Such classifications can be found in Table IV-1.

**Table IV-1: Sediment Containment System Classifications**

Type-1 Sediment Containment System	Design-Size Particle $\leq 0.075$ mm (very fine sand and clays)
Type-2 Sediment Containment System	$0.075 \text{ mm} < \text{Design-Size Particle} \leq 0.41 \text{ mm}$ (between very fine sand and medium sands)
Type-3 Sediment Containment System	Design-Size Particle $> 0.41$ mm (larger than medium sands)

Type-1 Sediment Containment System

A Type-1 SCS will require development of a structure to capture the maximum possible number of coarse silt and smaller suspended particles. Since particles of this size settle very slowly without flocculation, large storage volume Type-1 SCSs require long flow-path lengths, large containment volumes, and controlled discharges.

***Usually, development of Type-1 SCSs requires the expertise of a professional having skills in proper design of embankments, outlet structures, and spillways.***

Type-2 Sediment Containment System

The Type-2 SCS will capture suspended particles that settle faster than particles requiring Type-1 structures. Consequently, use of smaller storage volumes and shorter flow-path lengths is feasible. As with a Type-1 structure, these sediment control systems will also have controlled discharges. The traditional sediment trap best represents Type-2 systems.

***Depending upon the complexity of the structure, development of Type-2 SCSs may or may not require the expertise of a professional having skills in proper design of embankments, outlet structures, and spillways.***

Type-3 Sediment Containment System

The least effective methods to control suspended particles in runoff waters are Type-3 SCSs. These are not necessarily design structures, as found with Type-1 and Type-2 systems, but are often temporary BMPs commonly found on construction sites such as silt-fence barriers, inlet control structures, and ditch check structures.

Whenever significant runoff occurs, all Type-3 systems have very low effectiveness to control suspended particles without some additional treatment (e.g. adding a polymer). However, when runoff is small and adequate maintenance exists, the Type-3 sediment control systems may be effective in removing larger diameter suspended particles. Extensive information on Type-3 systems appears in Section V.

### ***Effectiveness of Sediment Containment Systems***

Field studies conducted by EPA (1976) to characterize containment systems and to evaluate their effectiveness for trapping sediment produced the following observations:

- Poor construction and inadequate maintenance of the sites were the major factors contributing to pond ineffectiveness.
- Predicted efficiency was higher than observed efficiency. Containment systems were effective in trapping sediment during baseline flows, but not during rainfall events.
- Outlet riser pipes and emergency spillways were not properly sized. Trash quickly clogged the pipes. The rising waters rushed over the unprotected spillways and scoured out large holes in the embankment.
- Containment systems that appeared to need cleaning transferred additional inflow directly to the outlet.

It was concluded from these studies that efficiencies of sediment containment systems could be increased by:

- Using techniques that reduce inflow energy
- Allowing sufficient travel time for design-size particles to fall through the water
- Preventing re-suspension of particles

Documentation on the effectiveness of containment systems for trapping suspended solids is limited and there are conflicting opinions on their actual effectiveness. However, the general concept is that if properly designed, constructed, and maintained, SCSs will always be effective in trapping some sediment.

Fifield (2004) developed equations found in Table IV-2, which can assist Designers with identifying *minimum parameters* for ensuring the development of effective containment structures. The equations assume removal of design size particles will occur when terminal (a.k.a. particle settling) velocity conditions exist.

One method (albeit not entirely accurate since sediments are not spherical in shape) for determining terminal velocities in water is to calculate the rate of fall based upon Stokes' Law. Table IV-3 illustrates particle-settling velocities for some design size particles at different temperatures as calculated by Stokes' Law.

Finally, equations found in Table IV-2 make reference to different graphs. Figure IV-1 provides an Apparent Effectiveness chart, which is a measure of a SCS to remove design size particles. Figure IV-2 provides a graph to determine the percent of Particles Equal to or Greater (PEG) than a design size particle that can become suspended in water when runoff events occur.

Use of the equations and accompanying graphs are illustrated in the example found at the end of this section. Additional information on sizing a SCS exists in the publication by Fifield (2004).

**Table IV-2: Minimum Parameters for Sediment Containment Systems (Fifield, 2004)**

MINIMUM PARAMETERS	ENGLISH UNITS
Surface Area	$SA_m = (1.2 \times Q_{out}) \div V_s$
Flow-Path Length	$L = [(L \div W_e) \times SA_m]^{0.5}$
Effective Width	$W_e = SA_m \div L$
Type-1 System Volume (Select the larger value)	$VOL_m \geq 2.2 \times SA_m$ or $VOL_m \geq$ runoff from a 2-year, 24-hour storm event for a minimum 3,600 $ft.^3$ of disturbed upstream land and for 10 acres.
Type-2 System Volume	$VOL_m \geq 2.2 \times SA_m$
Net Effectiveness	$NEff = AEff \times PEG$
Average Depth	$D_{avg} \geq 2.2 \text{ ft.}$
Outlet Depth	2.0 ft.

**LEGEND**

$AEff$  = Apparent effectiveness (%) of the SCS to remove design size (and larger) particles suspended in runoff waters =  $20(L \div W_e) - (L \div W_e)^2$

$D_{avg}$  = (Actual volume)  $\div$  (actual surface area)

$V_s$  = Particle settling velocity (ft./sec.)

$L$  = Particle flow distance (ft.)

$VOL_m$  = Minimum water volume (ft.<sup>3</sup>)

$NEff$  = Net effectiveness (%) of the SCS to remove all particles suspended in runoff waters

$W_e$  = Effective pond width (ft.)

$PEG$  = Percent of particles that are equal to or greater than the design-size particle (%)

$SA_m$  = Minimum water-surface area of system (ft.<sup>2</sup>)

$Q_{out}$  = Outflow (ft.<sup>3</sup>/sec.)

**Table IV-3: Estimated Settling Velocities for Suspended Particles (Specific Gravity = 2.65) in Water at Different Temperatures as Calculated by Stokes' Law**

DIAMETER (mm)	SETTLING VELOCITY IN FEET PER SECOND						PARTICLE
	40°F	50°F	60°F	70°F	80°F	90°F	
0.01	0.00019	0.00023	0.00026	0.00030	0.00034	0.00039	FINE SILT
0.02	0.00076	0.00090	0.00105	0.00121	0.00137	0.00154	MEDIUM SILT
0.03	0.00172	0.00203	0.00236	0.00271	0.00308	0.00347	
0.04	0.00305	0.00361	0.00420	0.00483	0.00548	0.00617	COARSE SILT
0.05	0.00477	0.00564	0.00656	0.00754	0.00856	0.00963	
0.06	0.00687	0.00811	0.00945	0.01086	0.01233	0.01387	
0.07	0.00935	0.01105	0.01286	0.01478	0.01678	0.01888	VERY FINE SAND
0.08	0.01221	0.01443	0.01680	0.01930	0.02192	0.02466	
0.09	0.01545	0.01826	0.02126	0.02443	0.02774	0.03121	
0.10	0.01908	0.02254	0.02625	0.03016	0.03425	0.03854	
	4.4°C	10.0°C	15.6°C	21.1°C	26.7°C	32.2°C	

*COMMONLY USED CONVERSION FACTORS*

1.0 *cm/sec.* = 0.03281 *ft. /sec.* = 0.3937 *in./sec.*

1.0 *m* = 3.281 *ft.* = 39.37 *in.*

1.0 *in.* = 2.54 *cm* = 25.4 *mm*

1.0 *ha.* = 2.471 *ac.* = 107,637 *ft.*<sup>2</sup>

1.0 *m*<sup>3</sup> = 35.3 *ft.*<sup>3</sup>

°C = 5/9 (°F - 32°)

NOTE: Design size particles larger than 0.10 *mm* are assumed to accelerate downward through water based upon Newtonian principles.

A conservative approach to sizing SCSs is to use a settling velocity when a water temperature is at its lowest value.

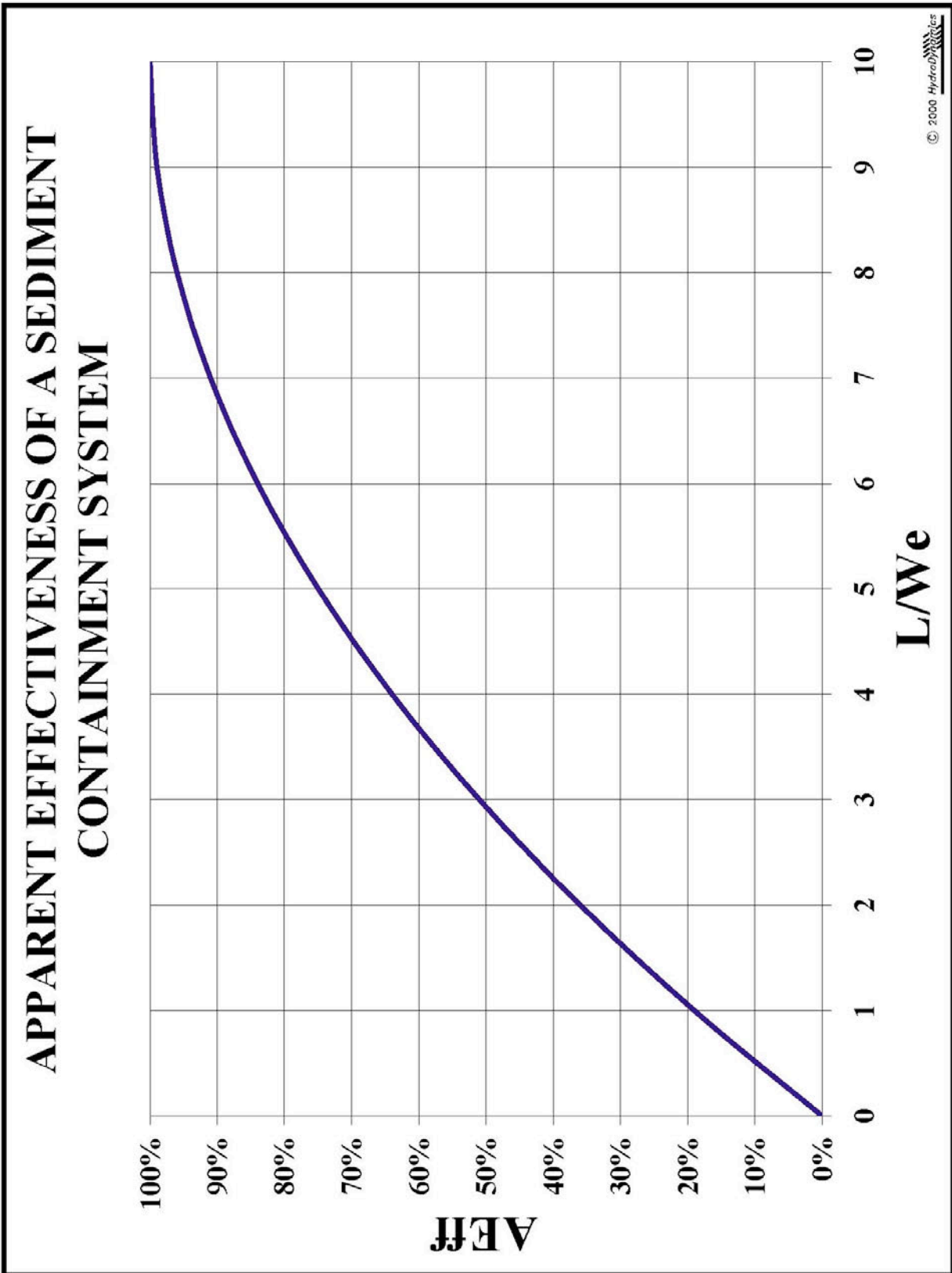

Figure IV-1: Apparent Effectiveness Graph (Fifield, 2004)

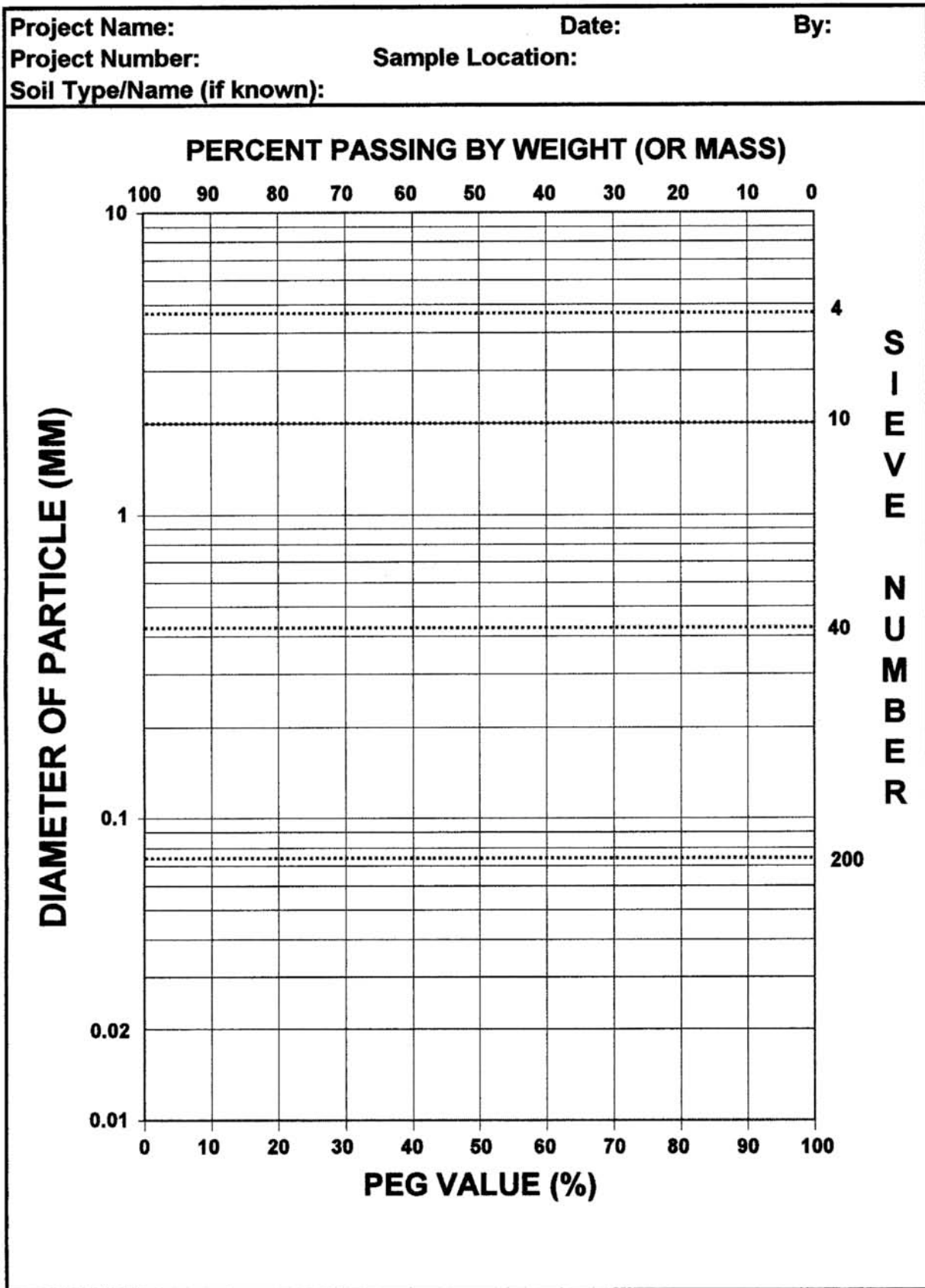

Figure IV-2: PEG Chart for Sediment Containment Systems (Fifield, 2004)

### ***Sediment Containment System Outlet Structures***

An important element of effective sediment containment systems is the outlet structure. These are required when containing runoff waters by any structure and can include the following systems.

#### Surface Skimmers

Skimmers remove water from the upper pond layers of a Type-1 SCS. Since the upper layer of water will have the least amount of suspended particles, discharges may be relatively free of sediment. This method is one of the more effective outlet structures to use for large containment systems (see Figure IV-4). Unfortunately, without additional treatment, discharges through a skimmer will usually not meet water quality turbidity standards. However, when a polymer or alum is introduced into the system that results in clear water within the upper (i.e. 3- to 6-inches) pond depths, then discharges through a skimmer may meet water quality turbidity standards.

Selection of a skimmer is dependent upon how long water is to be detained within the SCS. In absence of regulatory requirements, it is recommended that contained waters take about 48 hours to drain from an SCS.

#### Perforated Riser Pipes

Commonly used outlet structures for a Type-1 SCS are PVC or corrugated metal riser pipes. They release water through the top of the pipe and through side perforations. Since removal of contained waters occurs at different elevations, their effectiveness is less than skimmers (see Figure IV-5). In absence of regulatory guidelines, it is recommended that contained waters take about 48 hours to drain from an SCS.

Increased trapping efficiency of a riser pipe will occur by placing a rock barrier around the perforated section. However, when rock is not available, then placement of fabric material around a perforated riser pipe might have to occur. Unfortunately, use of the wrong fabric will result in clogging of the material resulting in the lack of drainage, which causes difficulties in maintenance of the structure. Therefore, it is critical that Designers specify the proper selection of fabric to ensure pore clogging does not happen.

## **DEWATERING ACTIVITIES**

Dewatering operations are an important component in the construction process and receive special attention from the local water management agencies. Regulators are especially concerned with the protection of wetlands from drawdown effects and protecting the receiving water body from sedimentation and capacity limitations.

### ***Types of Dewatering Methods***

#### Rim Ditching

Rim ditching is one of the more commonly used dewater methods where a ditch is excavated along the inside perimeter of the excavation area and a pump is used to keep the level of the ground water below the bottom surface of the excavation. This is the least expensive of the methods, requiring only a trash pump and backhoe. However, it produces the dirtiest water that must be treated prior to offsite discharge. While rim

ditching may be the cheapest method of construction dewatering, potential costs of treating water prior to discharge may result in much higher costs.

#### Sock Pipe/Horizontal Wells

The second common method of dewatering used in Florida includes the installation of perforated plastic pipes, usually wrapped in geosynthetic fabric, in a horizontal fashion on the inside of the excavation pit. While this method is more expensive to install than the traditional rim ditching, it does produce significantly cleaner discharge water. Initial installation of the sock pipe is limited to 15-20 feet. However deeper dewatering depth can be achieved in phases. The use of sock pipe is limited in clay soils.

#### Well Point Systems

The last of Florida's common method of dewatering includes the installation of multiple shallow wells that are attached to a main collection pipe attached to a central pump. Well point systems are typically used in linear projects such as installation of pipelines and culverts in roadways and shallow, linear ponds. The cost of this method is the most expensive of the three methods; however, it produces the cleanest water.

#### ***Turbidity Monitoring for Off-site Discharge***

When dewatering operations consist of off-site discharge, the contractor must ensure the effluent meets state water quality standards. The standards for discharging water into a receiving body cannot exceed 29 nephelometric turbidity units (NTU's) above background. Samples of the effluent should be taken at the discharge point into the receiving body. For best results, samples should be taken 2 times a day, at least 4 hours apart.

#### ***Using SCSs for Dewatering***

All of the dewatering activities described above usually will involve pumping water into a temporary containment system to ensure proper settlement of suspended particles. The equations found in Table IV-2 can assist Designers in development of a small SCS needed for these dewatering activities. Unfortunately, it is not known what the diameter of suspended particles will occur during pumping activities. However, Designers can provide preliminary assessments and recommendations using the following assumptions:

- The design size particle will be 0.02 mm
- The discharge rate of water out of the SCS will equal the pumping rate
- The minimum volume of contained water will be that found for a Type-2 system

Once actual field conditions exist, changes to Designer's preliminary recommendations may occur due to finding larger design size particles, greater outflows, use of polymers, and so forth. An example of sizing an SCS for dewatering activities is illustrated at the end of this section.

#### ***Increasing the Efficiency of a SCS***

How can more particles be captured by a SCS? One method is to capture all runoff waters. However, this is neither practical nor feasible. Another technique is to increase the flow path that runoff waters have to travel within the structure before discharging. Unfortunately, physical limitations of the pond, re-suspension problems, lack of uniform



sizing (a Stokes Law assumption for development of Table IV-3), and so forth will prevent this theoretical solution.

Sediment Containment System Internal Barrier and Weir

**WHAT IS ITS PURPOSE?**

To extend the flow path length of suspended particles within a sediment containment system.

**WHERE AND HOW IS IT COMMONLY USED (SEE FIGURE IV-3 FOR AN EXAMPLE)?**

- In ponds with small surface areas and small volumes.
- To increase the efficiency of a sediment containment system.
- In ponds with short flow path lengths.

**WHEN SHOULD IT BE INSTALLED?**

- Immediately after the sediment containment system is constructed.
- Before construction activities begin.
- While construction activities are occurring.

**WHEN SHOULD IT NOT BE INSTALLED?**

- Where high inflow runoff waters exist.
- As a “stand alone” method that is not part of a properly designed SCS.
- Where high internal pond flow velocities exists due to improper outlet structures.
- After grading activities are completed.

**WHAT NEEDS TO BE INSPECTED?**

- Does the fence need repair?
- Are metal stakes used and are they properly spaced?
- Is water flowing under the fence material?
- Does water flow over the weir?
- Does accumulated sediment need to be removed?
- Is the outlet structure causing ponding?

**WHAT MAINTENANCE ACTIVITIES CAN BE EXPECTED?**

- Repair and replacement of fence material.
- Repair of eroded ground.
- Removal of accumulated sediment.

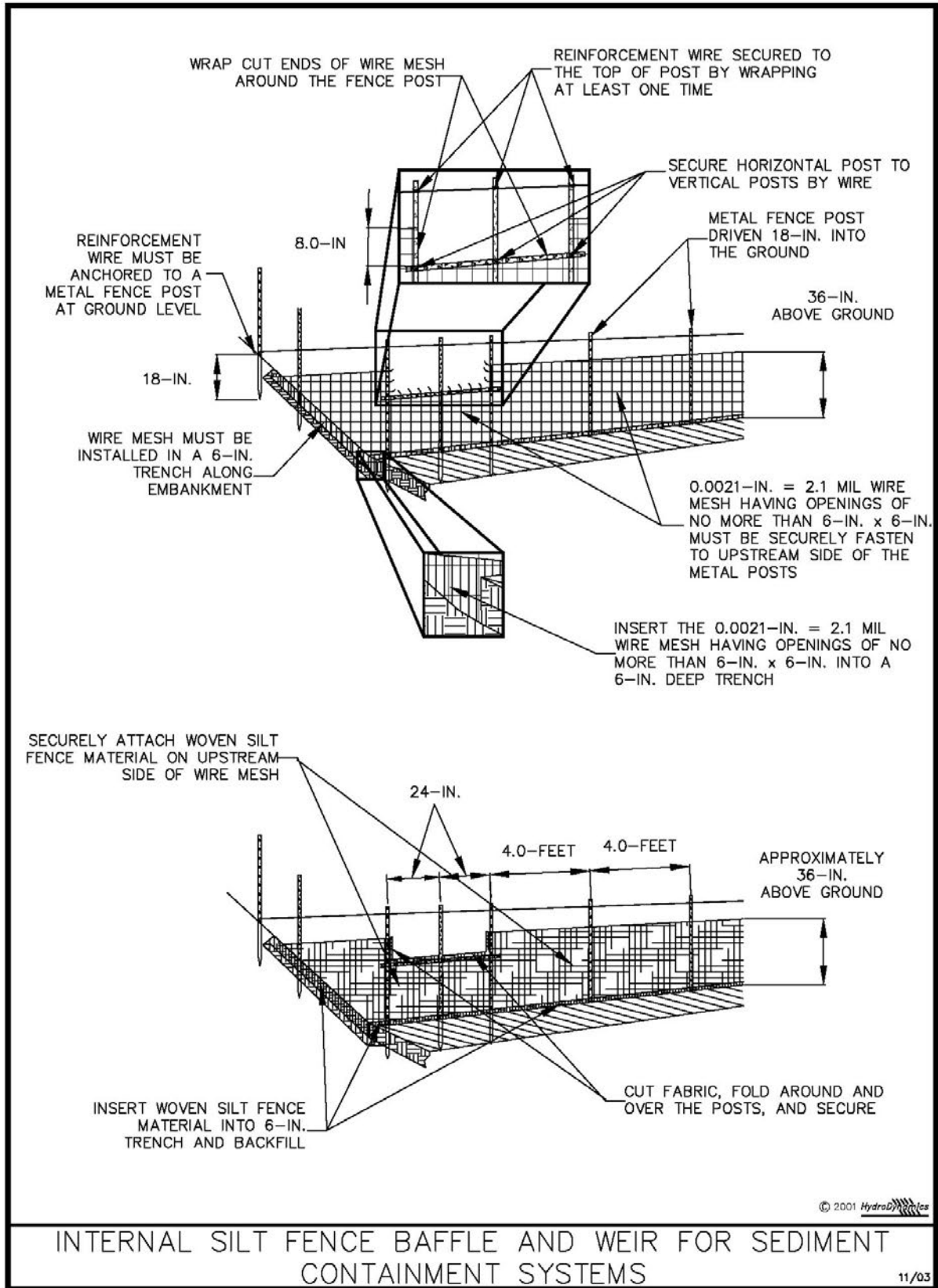

Figure IV-3: Illustration of a SCS Internal Silt Fence Barrier and Weir

Permission is given by HydroDynamics Incorporated to copy and reproduce this detail

Sediment Containment System: Faircloth® Surface Skimmer

**WHAT IS ITS PURPOSE?**

To drain a sediment containment system by removing water from the top layer where the least amount of suspended particles exist.

**WHERE AND HOW IS IT COMMONLY USED (SEE FIGURE IV-4)?**

- In Type-1 sediment containment systems
- At sites with large amounts of fines are suspended in runoff waters.
- Where low discharge of pond water is desired.

**WHEN SHOULD IT BE INSTALLED?**

- Immediately after a Type-1 sediment containment system is constructed.
- Before construction activities begin.
- To increase the effectiveness of capturing suspended particles that has been treated with a polymer or alum.
- While construction activities are occurring.

**WHEN SHOULD IT NOT BE INSTALLED?**

- In small basins better suited for Type-2 Sediment Containment Systems.

**WHAT NEEDS TO BE INSPECTED?**

- Overall appearance of the skimmer?
- Are there any cracks or broken pieces?
- Is the trash screen clogged?
- Is the skimmer draining properly?

**WHAT MAINTENANCE ACTIVITIES CAN BE EXPECTED?**

- Removal of trash from orifice.
- Repair of unit due to vandalism.

*Notes*

- Unless advised otherwise, resident time of contained waters within an SCS is at least 48 hours.
- See Table IV-2 for equations to size an SCS as well as examples at the end of this section.

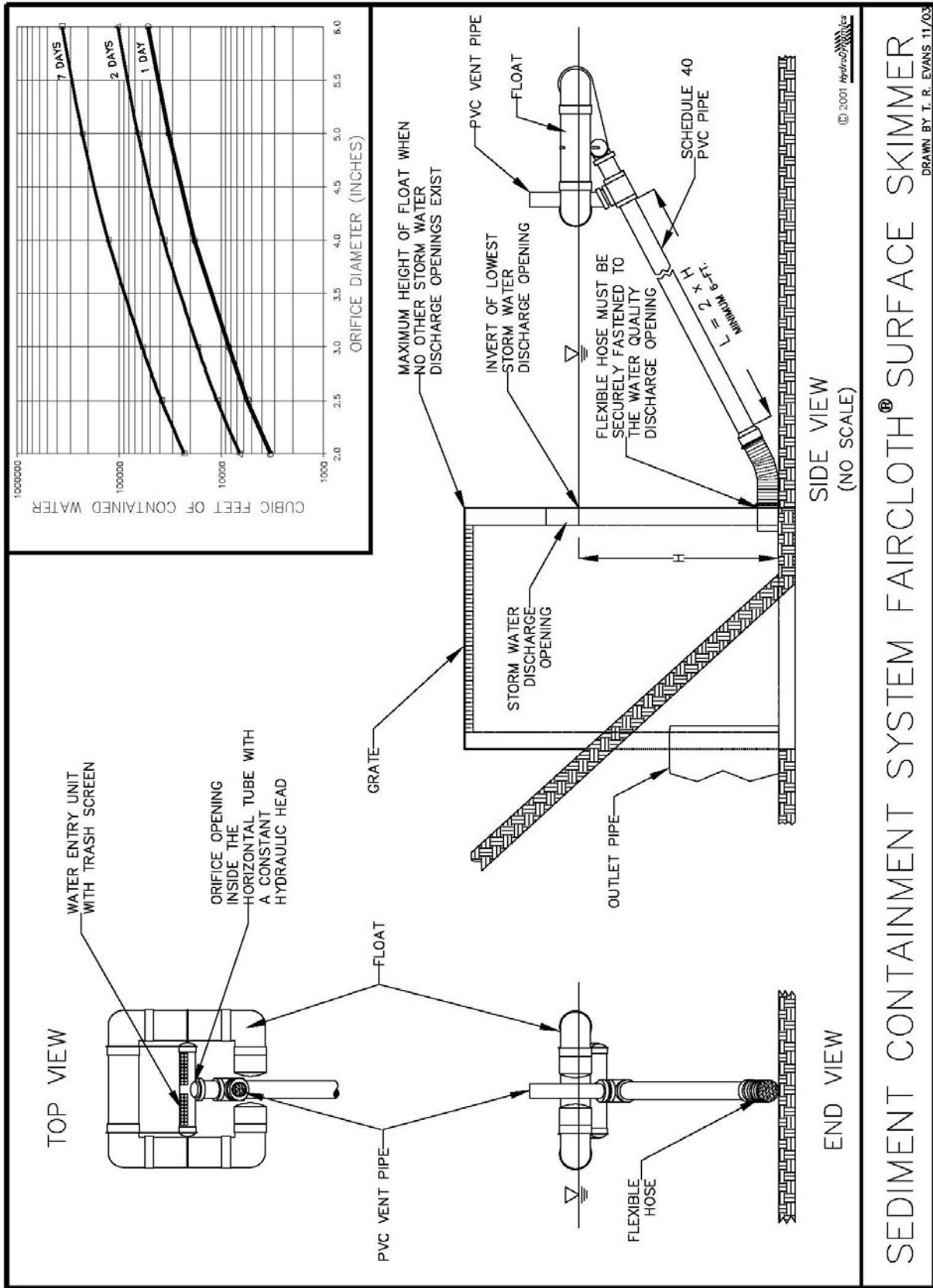

Figure IV-4: Illustration of a SCS Faircloth® Surface Skimmer

Permission is given by HydroDynamics Incorporated to copy and reproduce this detail

Sediment Containment System: IAS<sup>®</sup> Water Quality Skimmer

**WHAT IS ITS PURPOSE?**

To increase the TSS removal efficiencies of sediment basins, sediment traps, and water quality ponds.

**WHERE AND HOW IS IT COMMONLY USED (SEE FIGURE IV-5)?**

The skimmer is used as a replacement for the riser/barrel in sediment traps. It serves as the dewatering device in sediment basins. The skimmer removes the cleaner surface water from the BMP, which reduces the TSS and improves the turbidity.

**WHEN SHOULD IT BE INSTALLED?**

The skimmer is installed in conjunction with the construction of sediment traps, sediment basins and water quality ponds.

**WHEN SHOULD IT NOT BE INSTALLED?**

The skimmer should not be installed in any other erosion control measure other than sediment traps, sediment basins or water quality ponds.

**WHAT NEEDS TO BE INSPECTED?**

The skimmer has color banding to allow for easy identification of the skimmer size. The skimmer has this side up and this side down stickers to indicate orientation. The skimmer's general condition should be checked (cracking, ect.)

**WHAT MAINTENANCE ACTIVITIES CAN BE EXPECTED?**

None anticipated.

*Notes*

Skimmers will need some onsite assembly. Assembly instructions are included in the kit as shipped from the manufacturer. Additional information can be found at [www.iasllcusa.com](http://www.iasllcusa.com)

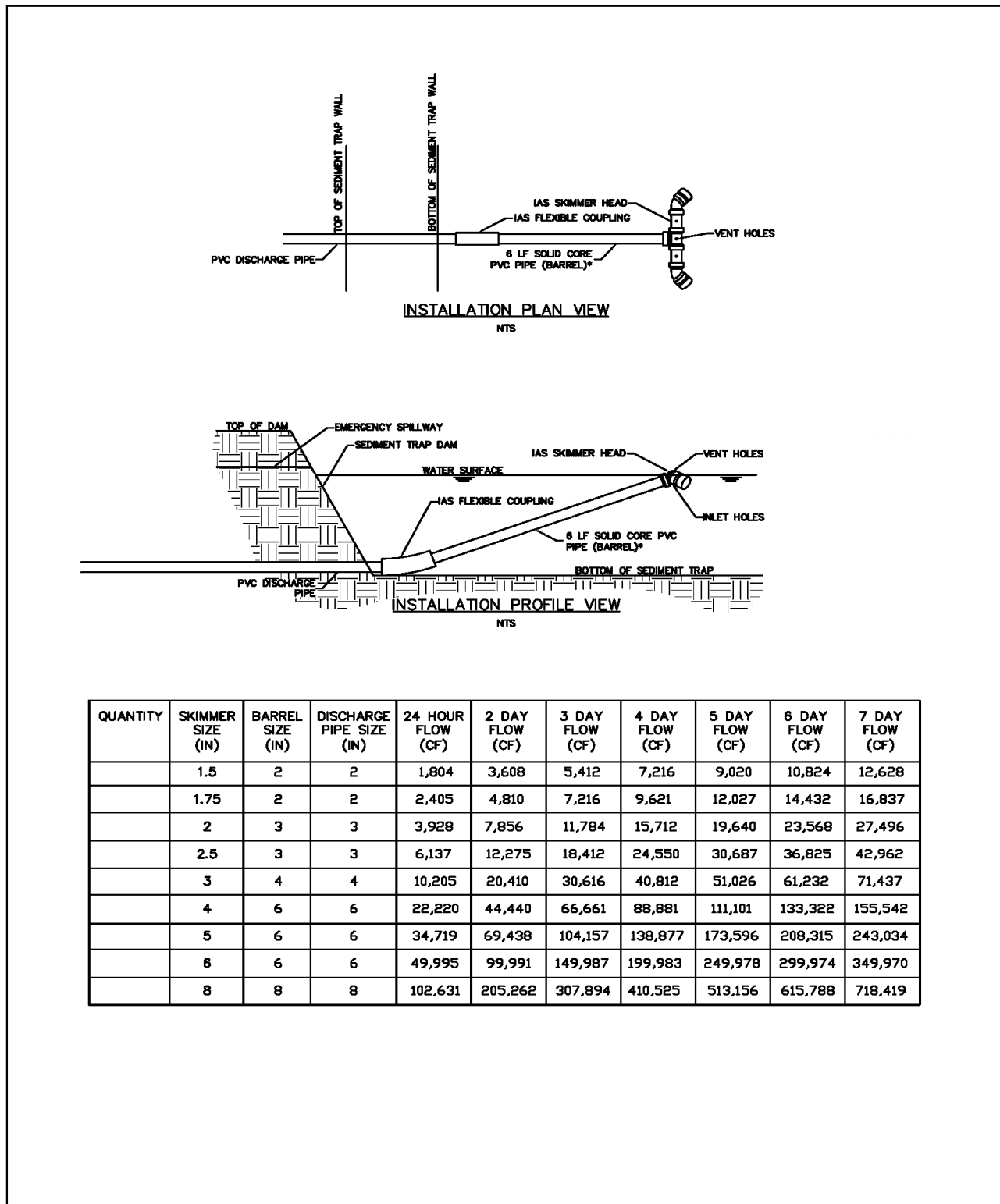

Figure IV-5: Illustration of a SCS IAS® Water Quality Skimmer

### Sediment Containment System Riser Pipe Outlet Structure

#### **WHAT IS ITS PURPOSE?**

Provide controlled release of contained water.

#### **WHERE AND HOW IS IT COMMONLY USED (SEE FIGURE IV-6)?**

- Provide a method to allow for the slow discharge of contained runoff waters.
- Commonly used in Type-1 sediment containment systems.

#### **WHEN SHOULD IT BE INSTALLED?**

- Immediately after the sediment containment system is constructed.
- Before construction activities begin.
- While construction activities are occurring.

#### **WHEN SHOULD IT NOT BE INSTALLED?**

- After grading activities are completed.

#### **WHAT NEEDS TO BE INSPECTED?**

- Is the rock filled with sediment?
- Does water drain through rock?
- Is the right sized rock used?
- Is top of riser pipe below the spillway and open?

#### **WHAT MAINTENANCE ACTIVITIES CAN BE EXPECTED?**

- Replacement of rock.
- Removal of sediment.

#### *Notes*

- It is important that wrapping a riser pipe of an SCS with a fabric material not occur since clogging with clay and silt particles will occur, which will prevent proper drainage.
- Sizing is dependent upon the amount of inflow and required outflow from the containment system.
- Unless advised otherwise, resident time of contained waters within an SCS is at least 48 hours.
- See Table IV-2 for equations to size an SCS as well as examples at the end of this section.



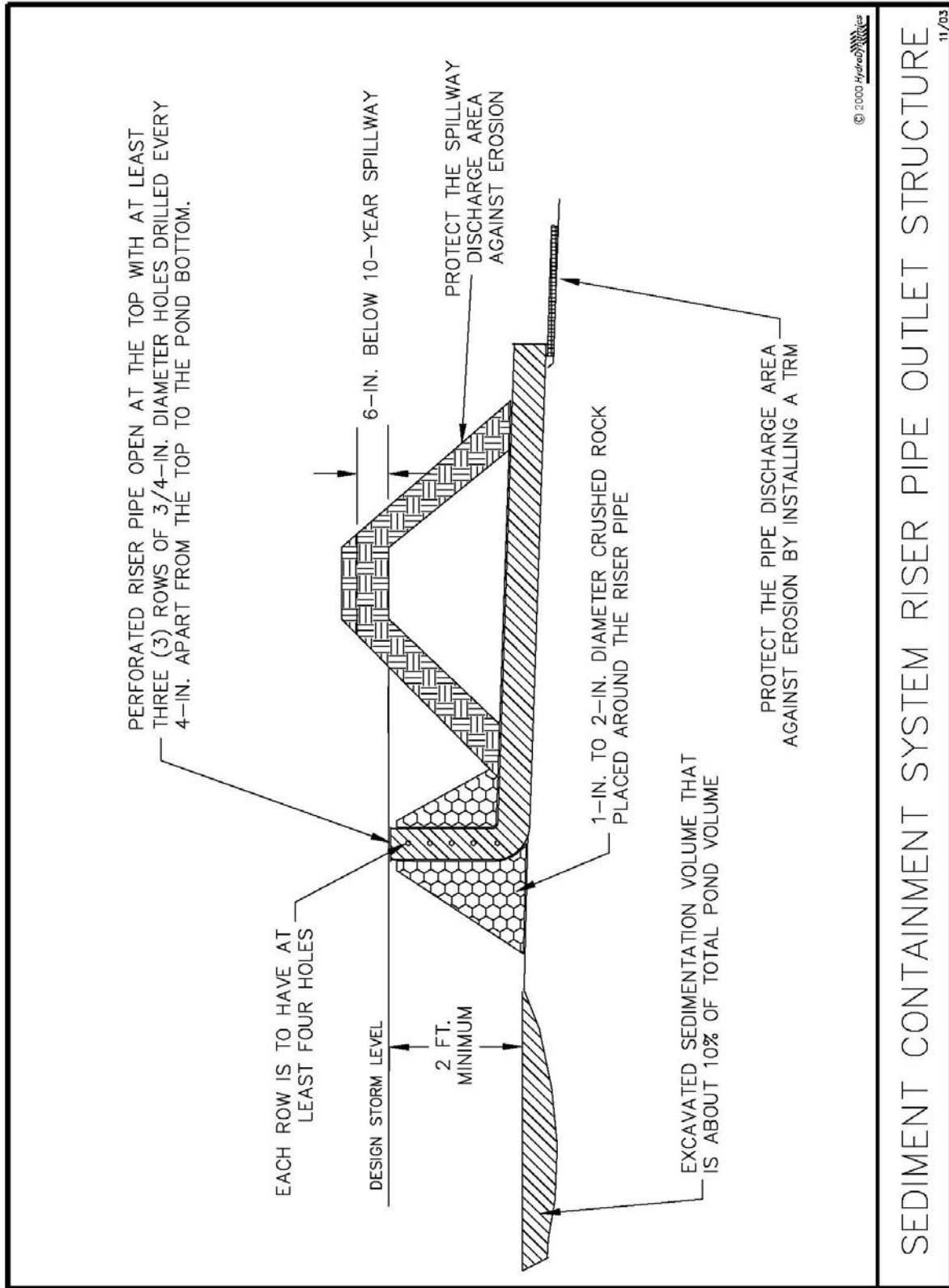

**Figure IV-6: Illustration of a SCS Riser Pipe Outlet Structure**

Permission is given by HydroDynamics Incorporated to copy and reproduce this detail

During the construction phase of a project, significant amounts of sediment can potentially flow into (and often out of) a SCS. Increased efficiency can occur by trapping larger diameter particles with a pre-sedimentation (a.k.a. forebay) and/or introducing a polymer (when suspended clay colloidal materials exist) or possibly alum (for other types of colloidal materials).

### Pre-Sedimentation Basins

Essentially, a pre-sedimentation basin is a small SCS specifically designed to capture anticipated sediment loading from disturbed lands. However, it is important that sufficient volume exist to capture larger diameter sediments while inflows equal outflows. Figure IV-7 illustrates some conceptual pre-sedimentation basins in which deposition of larger suspended particles occur.

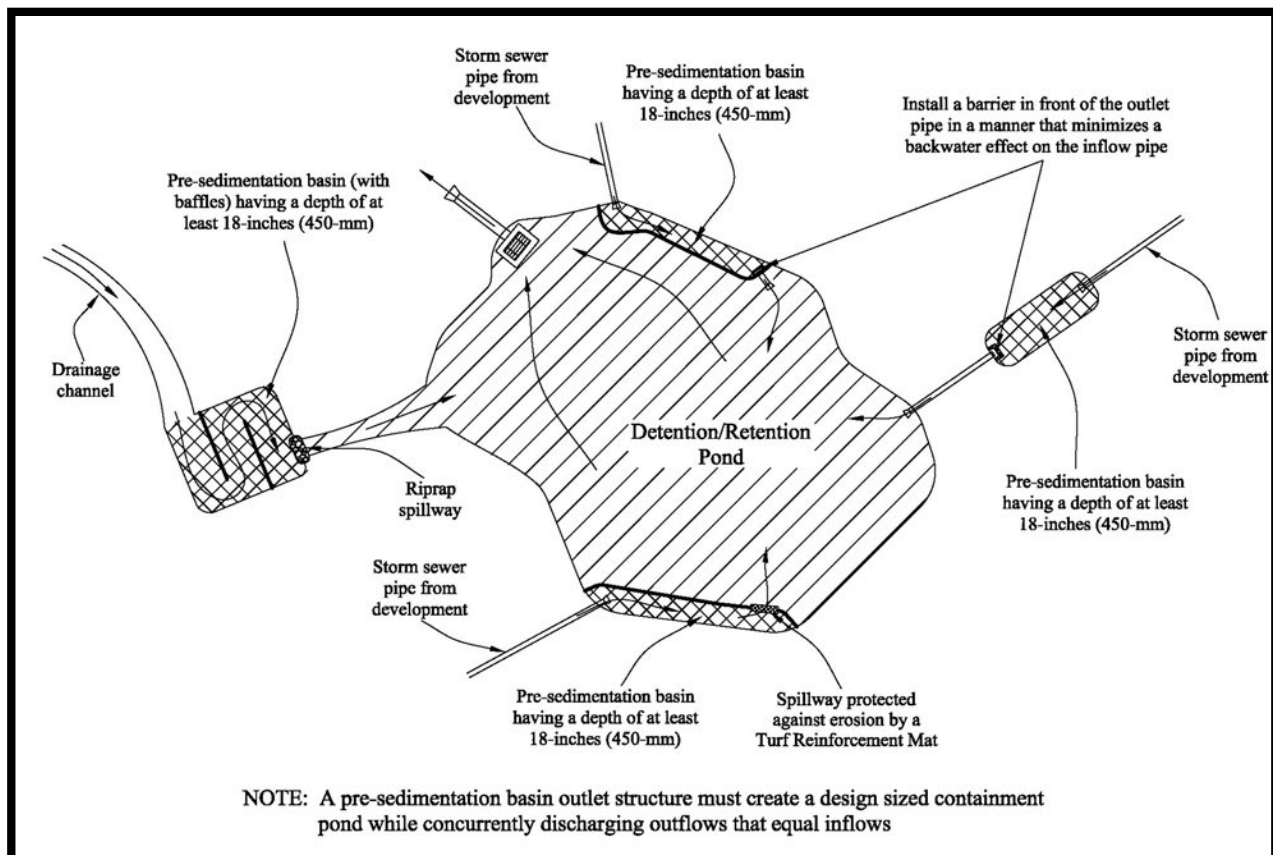

**Figure IV-7: Conceptual Pre-Sedimentation (a.k.a. Forebay) Basins (No Scale)**

The concept of a pre-sedimentation basin is simple; instead of allowing inflow waters to discharge directly into a large detention/retention pond, they first enter a smaller containment system to allow for the deposition of larger suspended particles. These pre-sedimentation basins can be periodically cleaned to remove accumulated sediments.

During the land development or linear phase of a project, Designers must use data on upstream erodibility of soils, hydrologic characteristics of contributing basins, and a design storm event to determine the size of a pre-sedimentation basin. By applying and modifying information found in Fifield (2004), use the following equations to calculate the size of a pre-sedimentation basin (see examples at the end of this section):

$$\text{Sediment Yield} = (K_{\text{site}} + K_{\text{chart}}) \times LR \times A^{1.12} \quad (\text{cubic feet}) \quad \text{Equation IV-7}$$

$$\text{Surface Area} = 0.67 \times \text{Sediment Yield} \quad (\text{square feet}) \quad \text{Equation IV-8}$$

$$\text{Length} = 3.79 \times (\text{Surface Area})^{0.50} \quad (\text{feet}) \quad \text{Equation IV-9}$$

$$\text{Width} = 0.10 \times \text{Length} \quad (\text{feet}) \quad \text{Equation IV-10}$$

Where  $K_{\text{site}}$  = Anticipated Soil Erodibility Factor of the site

$K_{\text{chart}}$  = Soil Erodibility Factor found on Figure IV-8 through Figure IV-11

$LR$  = Loading Ratio value found from Figure IV-8 through Figure IV-11

$A$  = Contributing area in acres

It is important that all pre-sedimentation basins have a minimum depth of 18 inches.

An added benefit for full build out conditions may exist when installing and maintaining a pre-sedimentation basin that becomes part of a detention/retention facility. Such a facility can be part of the water quality features needed to ensure that the project remains compliant for post-construction conditions.

#### Barriers for Pre-Sedimentation Basins

A riprap barrier at the discharge end of a pre-sedimentation basin provides a simple method to detain runoff waters and still allow for the deposition of larger sized suspended particles while ensuring inflow values equal outflow values. Figure IV-12 through Figure IV-15 illustrates these types of containment structures.

Use of these barriers is more commonly for “in-line” basins placed within drainage channels. It is important that sufficient spillway width be available to ensure flood flow conditions can occur without damaging the structure.

Another type of barrier consists of material placed in front of a culvert in a manner that allows for pond development and conveyance of inflow waters from drainage swales or upstream storm sewer systems. It is important that proper design and installation occur to ensure outflow values are not less than inflow values (see Figure IV-15).

Occasionally there is a need for small containment systems such as when pumping water from behind cofferdams or small dewatering projects. The filter bag (see Figure IV-16) may provide a temporary method for removing larger diameter particles suspended in runoff waters.

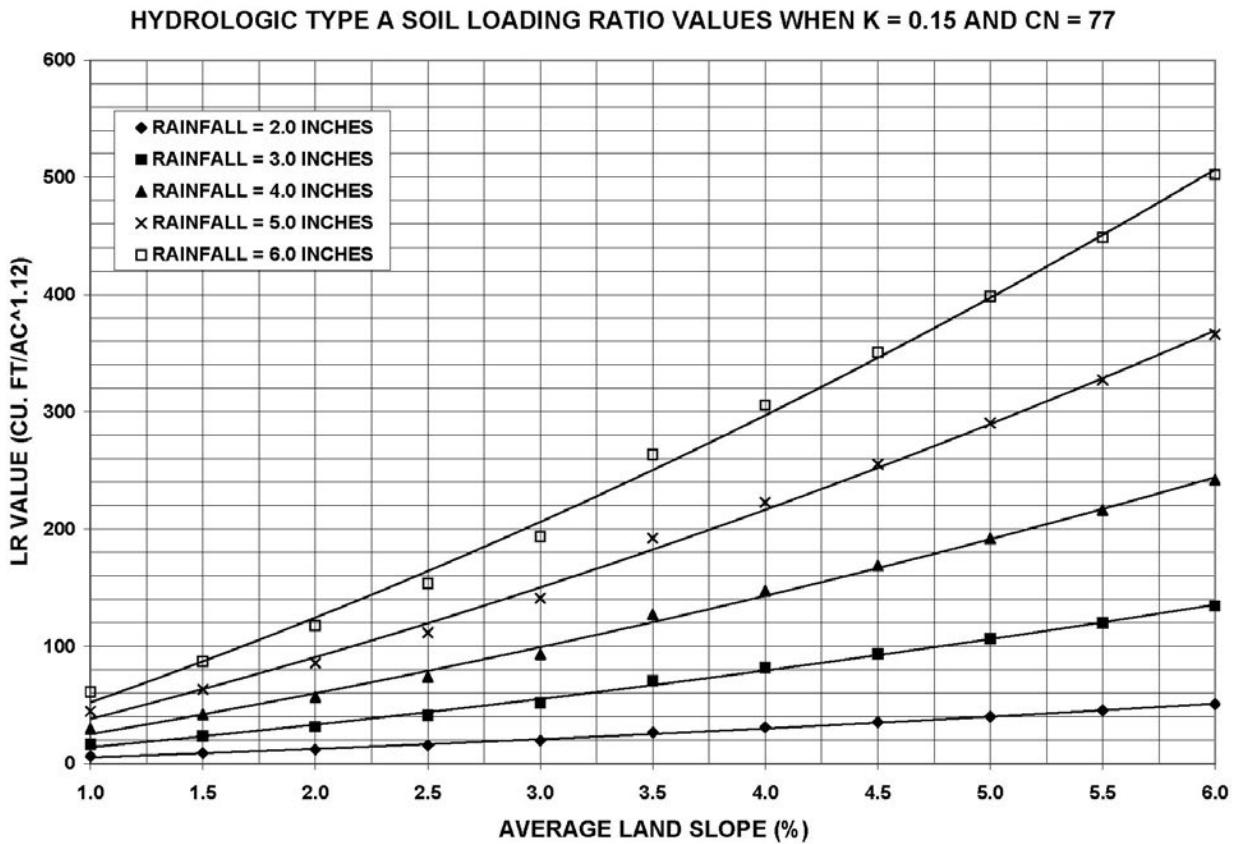
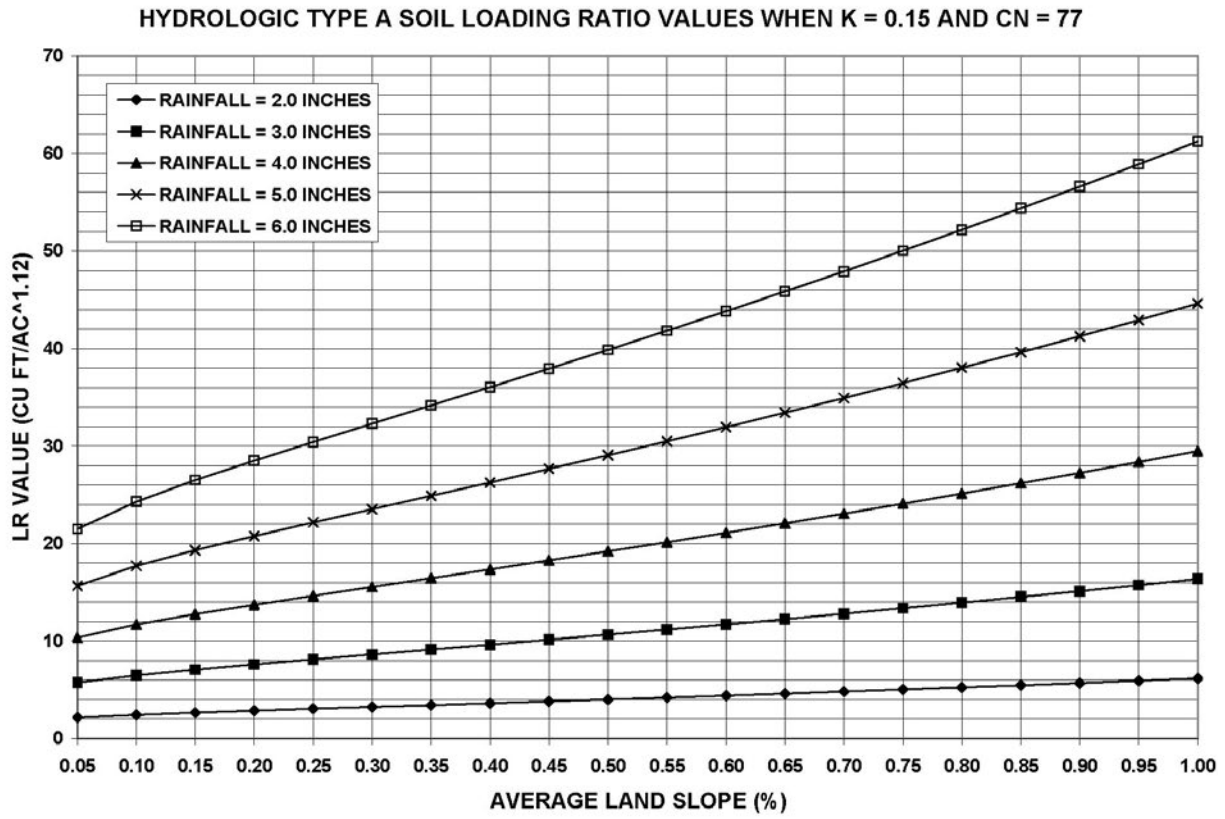
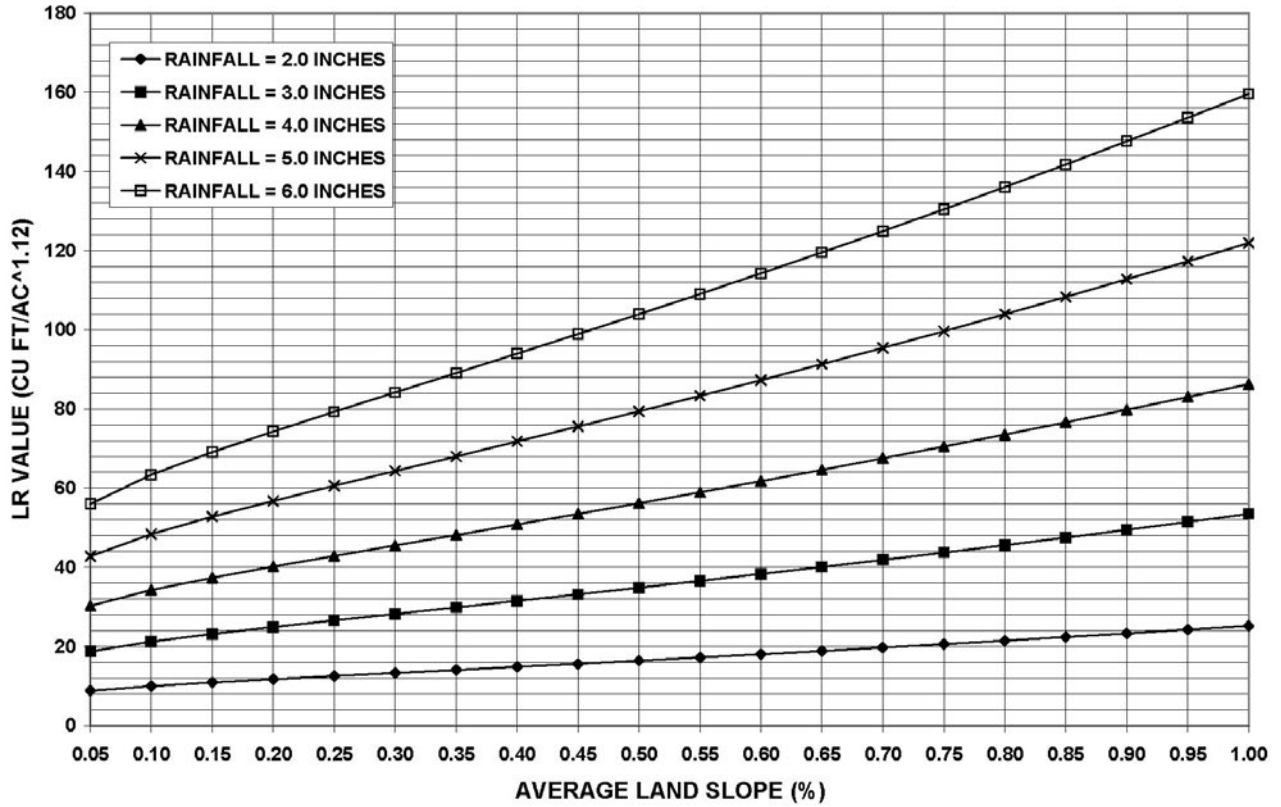

Figure IV-8: Hydrologic Type A Soils Loading Ratio Graph

HYDROLOGIC TYPE B SOIL LOADING RATIO VALUES WHEN K = 0.30 AND CN = 86



HYDROLOGIC TYPE B SOIL LOADING RATIO VALUES WHEN K = 0.30 AND CN = 86

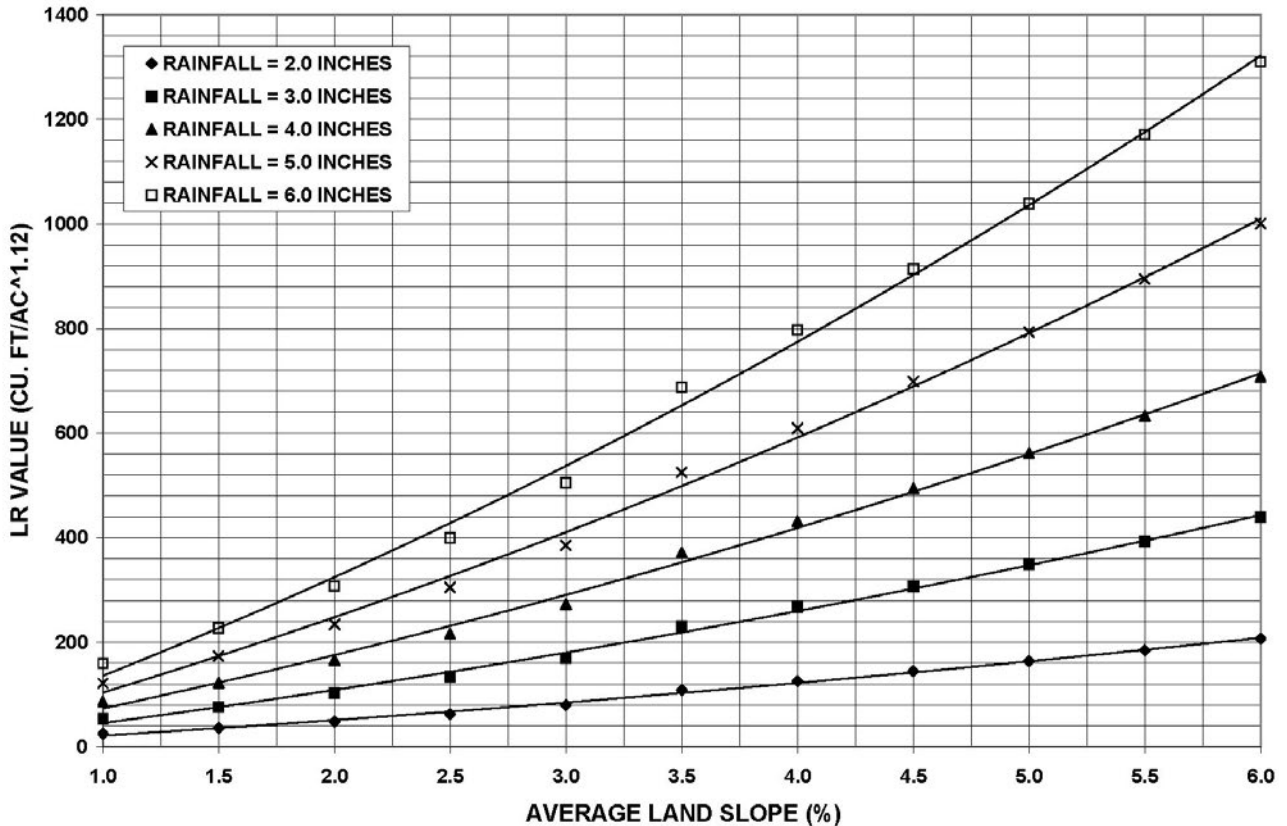
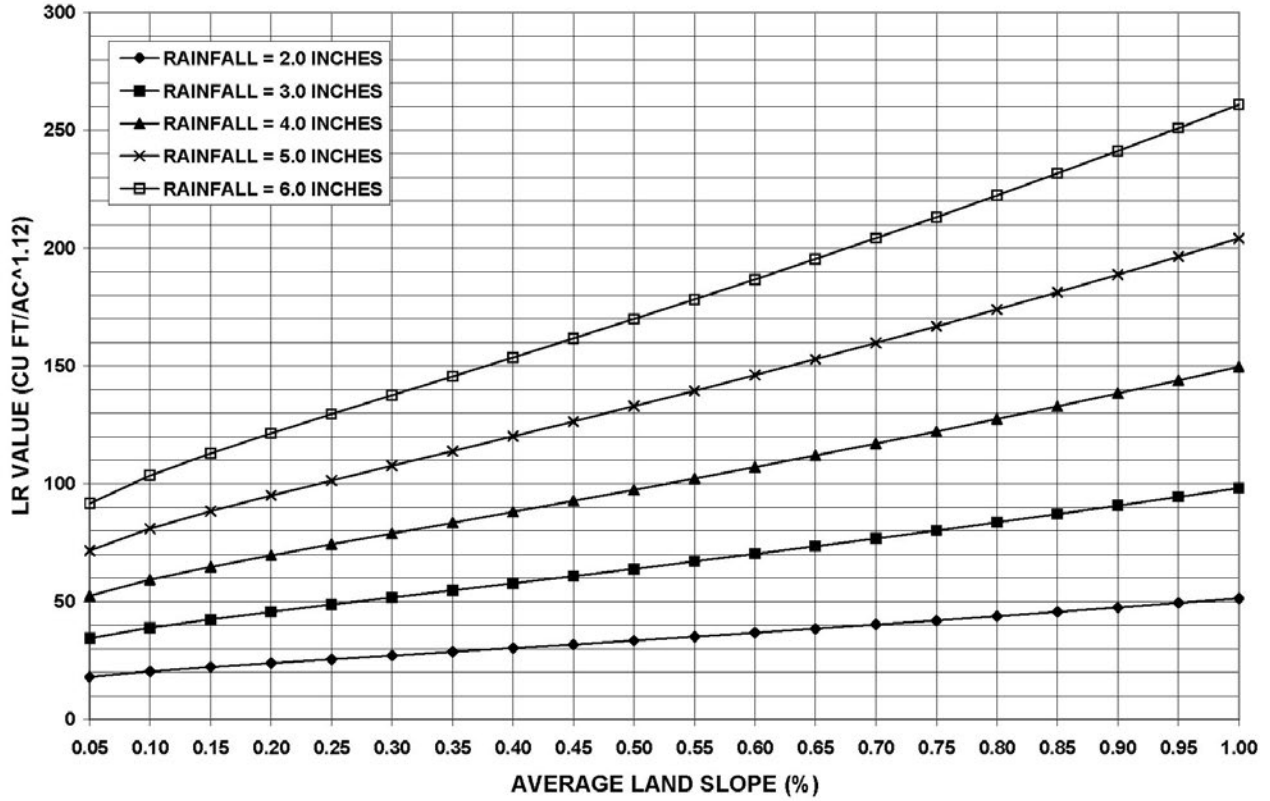

Figure IV-9: Hydrologic Type B Soils Loading Ratio Graph

HYDROLOGIC TYPE C SOIL LOADING RATIO VALUES WHEN K = 0.43 AND CN = 91



HYDROLOGIC TYPE C SOIL LOADING RATIO VALUES WHEN K = 0.43 AND CN = 91

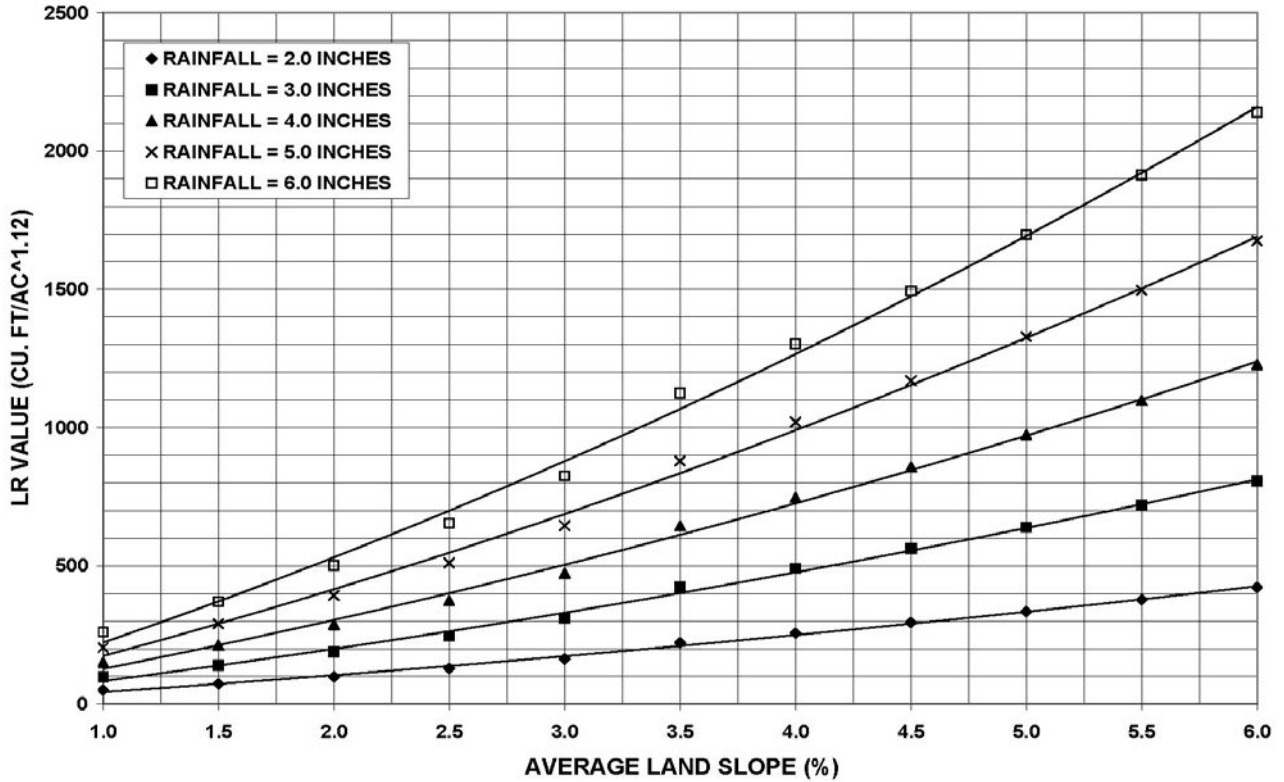
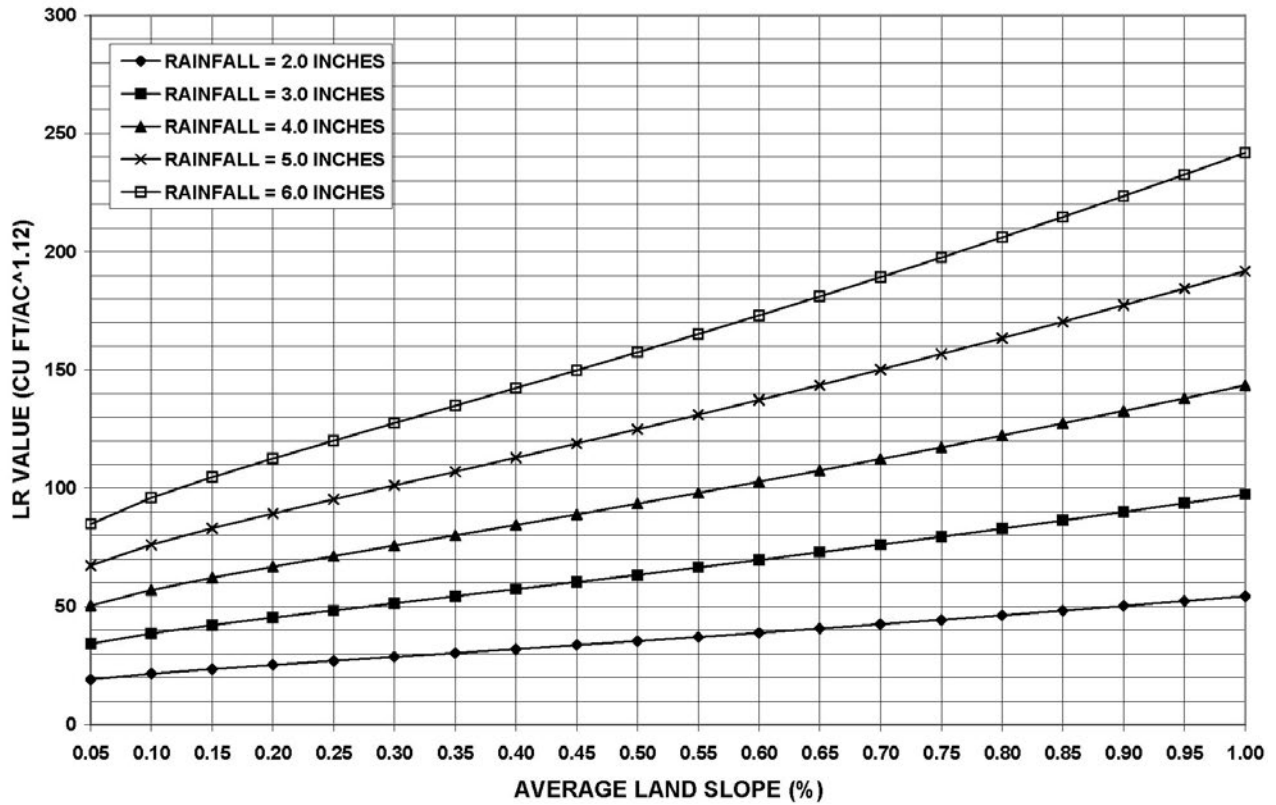

Figure IV-10: Hydrologic Type C Soils Loading Ratio Graph

HYDROLOGIC TYPE D SOIL LOADING RATIO VALUES WHEN K = 0.37 AND CN = 94



HYDROLOGIC TYPE D SOIL LOADING RATIO VALUES WHEN K = 0.37 AND CN = 94

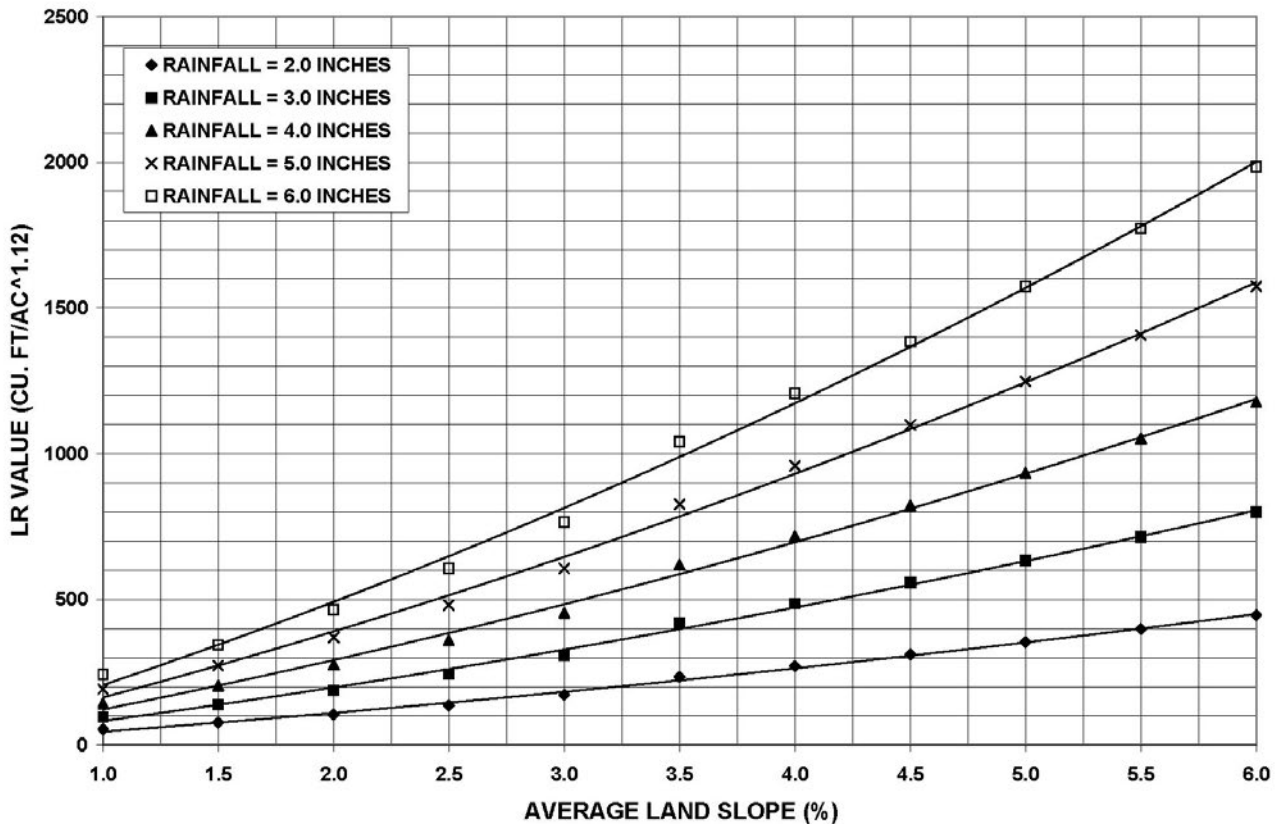

Figure IV-11: Hydrologic Type D Soils Loading Ratio Graph

### Sediment Containment System Rock Berm Outlet Structure

#### **WHAT IS ITS PURPOSE?**

Provide a relatively maintenance free method for releasing contained waters when outflow values are equal to inflow values.

#### **WHERE AND HOW IS IT COMMONLY USED(SEE FIGURE IV-11)?**

- Method of a structure to capture larger diameter suspended particles.
- Provides development of small wetlands after grading is done.
- Allows the discharge of contained waters.
- Relatively maintenance free outlet structure.

#### **WHEN SHOULD IT BE INSTALLED?**

- Immediately after the sediment containment system is constructed.
- Before major construction activities begin.
- While construction activities are occurring.

#### **WHEN SHOULD IT NOT BE INSTALLED?**

- After grading activities are completed unless wetlands are to be developed.

#### **WHAT NEEDS TO BE INSPECTED?**

- Are the containment berms vegetated?
- Does a low point in the rock exist?
- Have any of the containment berms been destroyed?
- Does water drain through the rock?

#### **WHAT MAINTENANCE ACTIVITIES CAN BE EXPECTED?**

- Repair destroyed sections.
- Removal of sediment.
- Removal of the rock berm.

#### *Notes*



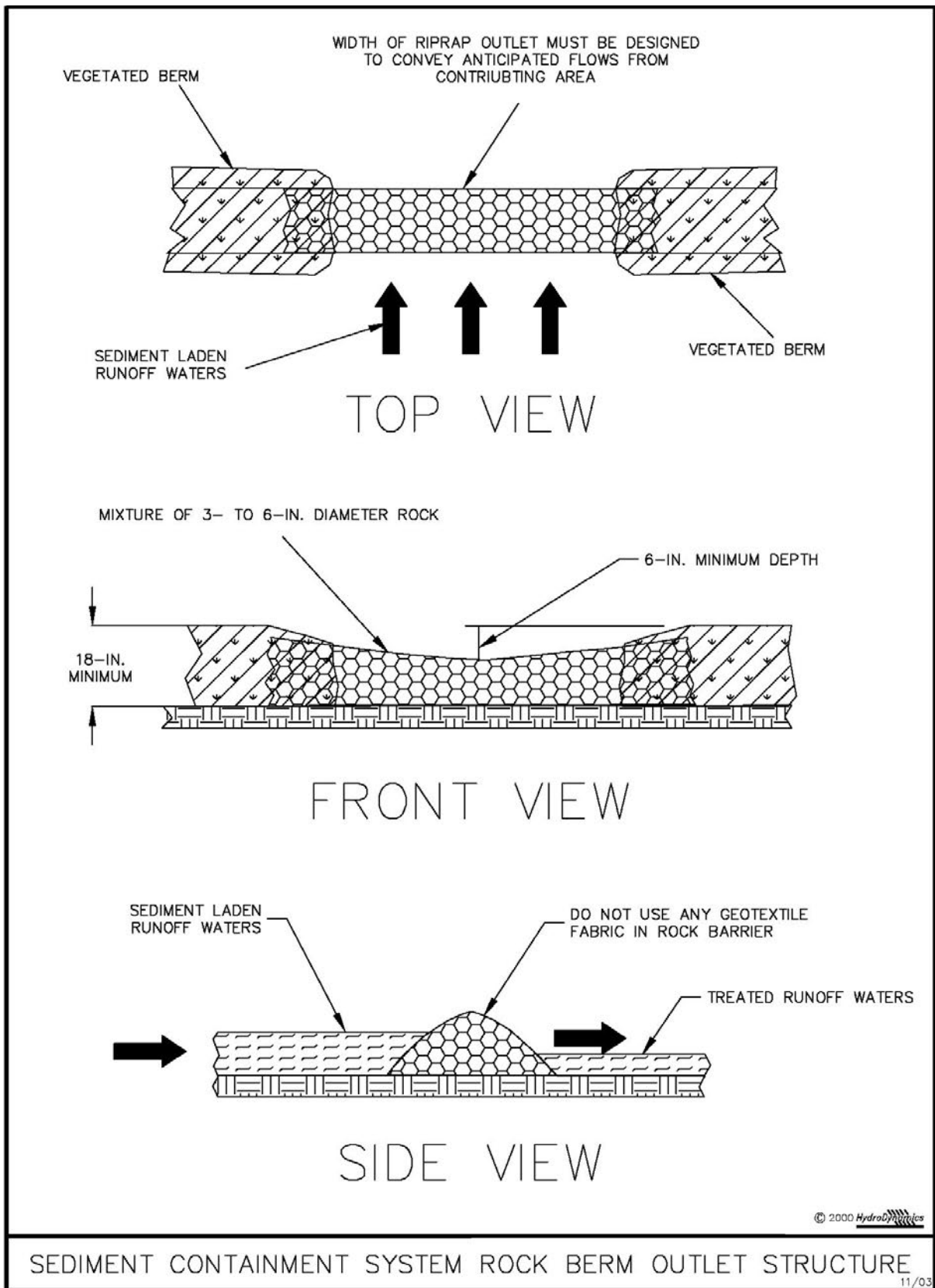

**Figure IV-12: Illustration of a SCS Rock Berm Outlet Structure**

Permission is given by HydroDynamics Incorporated to copy and reproduce this detail

### Sediment Containment System Single Chamber

#### **WHAT IS ITS PURPOSE?**

To cause the deposition of large diameter suspended particles in runoff waters from small contributory basins.

#### **WHERE AND HOW IS IT COMMONLY USED (SEE FIGURE IV-12)?**

- On construction sites.
- Areas where limited space exists for a sediment containment system.
- Low point of small drainage basins.
- Where capture of larger size particles found in runoff waters is required.

#### **WHEN SHOULD IT BE INSTALLED?**

- Before construction activities begin.
- While construction activities are occurring.
- To treat waters being pumped from behind coffer dams and for dewatering activities.

#### **WHEN SHOULD IT NOT BE INSTALLED?**

- After grading activities are finished.
- As the only method to capture suspended particles without some type of chemical treatment.

#### **WHAT NEEDS TO BE INSPECTED?**

- How much sediment is in the chamber?
- Will the structure capture runoff?
- Should the riprap outlet structure be wider?
- Will runoff flow over the riprap outlet structure?
- Are the lengths and widths correct as calculated by the Designer?
- Is the inflow higher than the outflow?

#### **WHAT MAINTENANCE ACTIVITIES CAN BE EXPECTED?**

- Removal of sediment.
- Repair of destroyed embankments
- Repair of destroyed riprap.
- Ensure establishment of vegetation occurs on all embankments.

#### *Notes*

- Basin parameters  $L$  = Length and  $W_e$  = Width as calculated by the Designer from equations found in the pre-sedimentation basin section.
- Develop the outlet structure so that it is able to safely convey flood flows for design storm events.

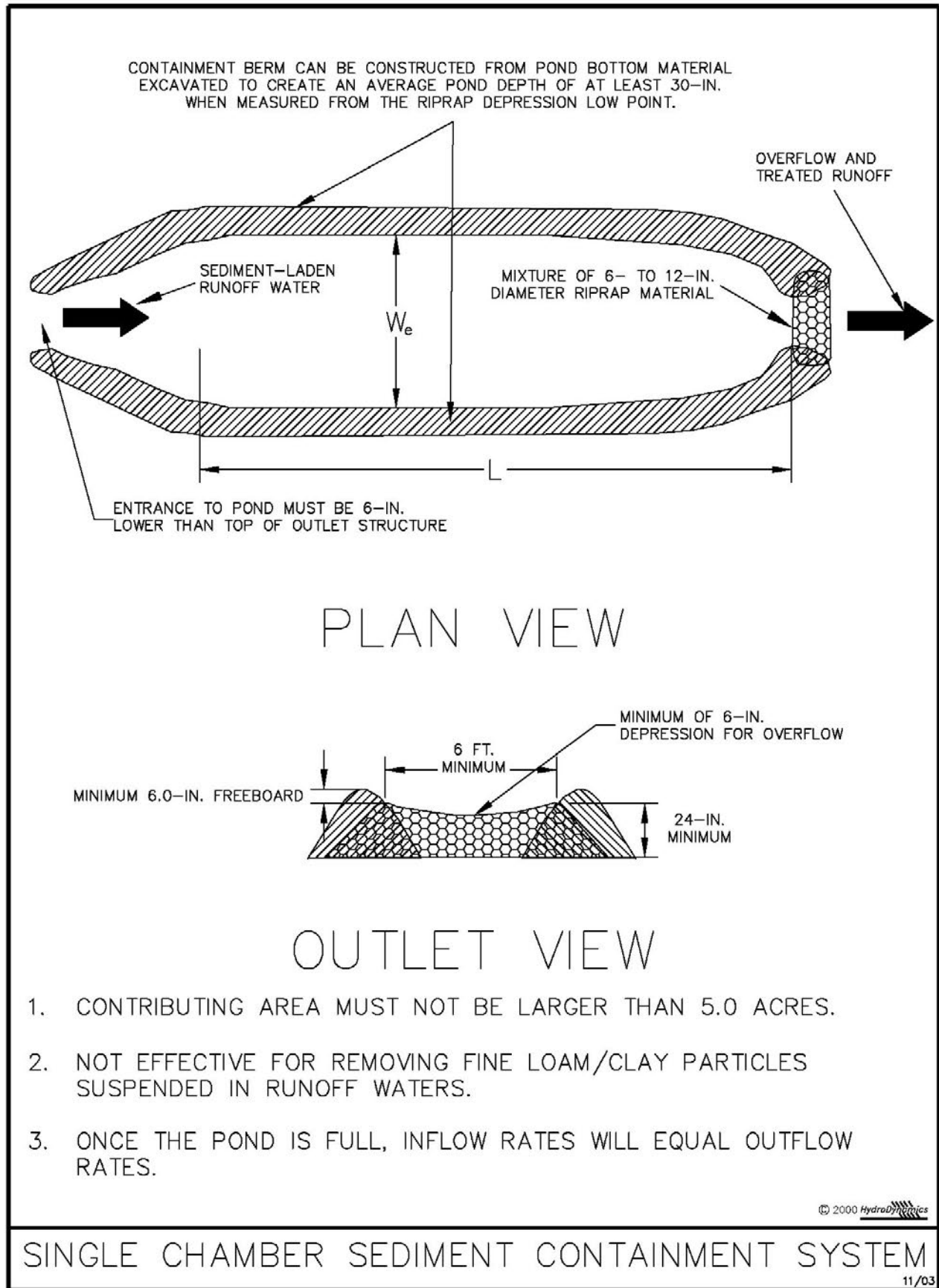

**Figure IV-13: Illustration of a Single Chamber SCS**

Permission is given by HydroDynamics Incorporated to copy and reproduce this detail  
IV-29

### Sediment Containment System Double Chamber

#### **WHAT IS ITS PURPOSE?**

To cause the deposition of large diameter suspended particles in runoff waters from small contributory basins.

#### **WHERE AND HOW IS IT COMMONLY USED (SEE FIGURE IV-13)?**

- On construction sites.
- Areas where limited space exists for a sediment containment system.
- Low point of small drainage basins.
- Where capture of larger size particles found in runoff waters is required.

#### **WHEN SHOULD IT BE INSTALLED?**

- Before construction activities begin.
- While construction activities are occurring.
- To treat waters being pumped from behind cofferdams and for dewatering activities.

#### **WHEN SHOULD IT NOT BE INSTALLED?**

- After grading activities are finished.
- As the only method to capture suspended particles without some type of chemical treatment.

#### **WHAT NEEDS TO BE INSPECTED?**

- How much sediment is in the chamber?
- Will the structure capture runoff?
- Should the riprap outlet structure be wider?
- Will runoff flow over the riprap outlet structure?
- Are the lengths and widths correct as calculated by the Designer?
- Is the inflow higher than the outflow?

#### **WHAT MAINTENANCE ACTIVITIES CAN BE EXPECTED?**

- Removal of sediment.
- Repair of destroyed embankments.
- Repair of destroyed riprap.
- Ensure establishment of vegetation occurs on all embankments.

#### *Notes*

- The length parameter is to be reduced by 50% (i.e.,  $L_{\text{final}} = \frac{1}{2} \times \text{Length}$ ) as calculated by the Designer from equations found in the pre-sedimentation basin section.
- Develop the outlet structure so that it is able to safely convey flood flows for design storm events.

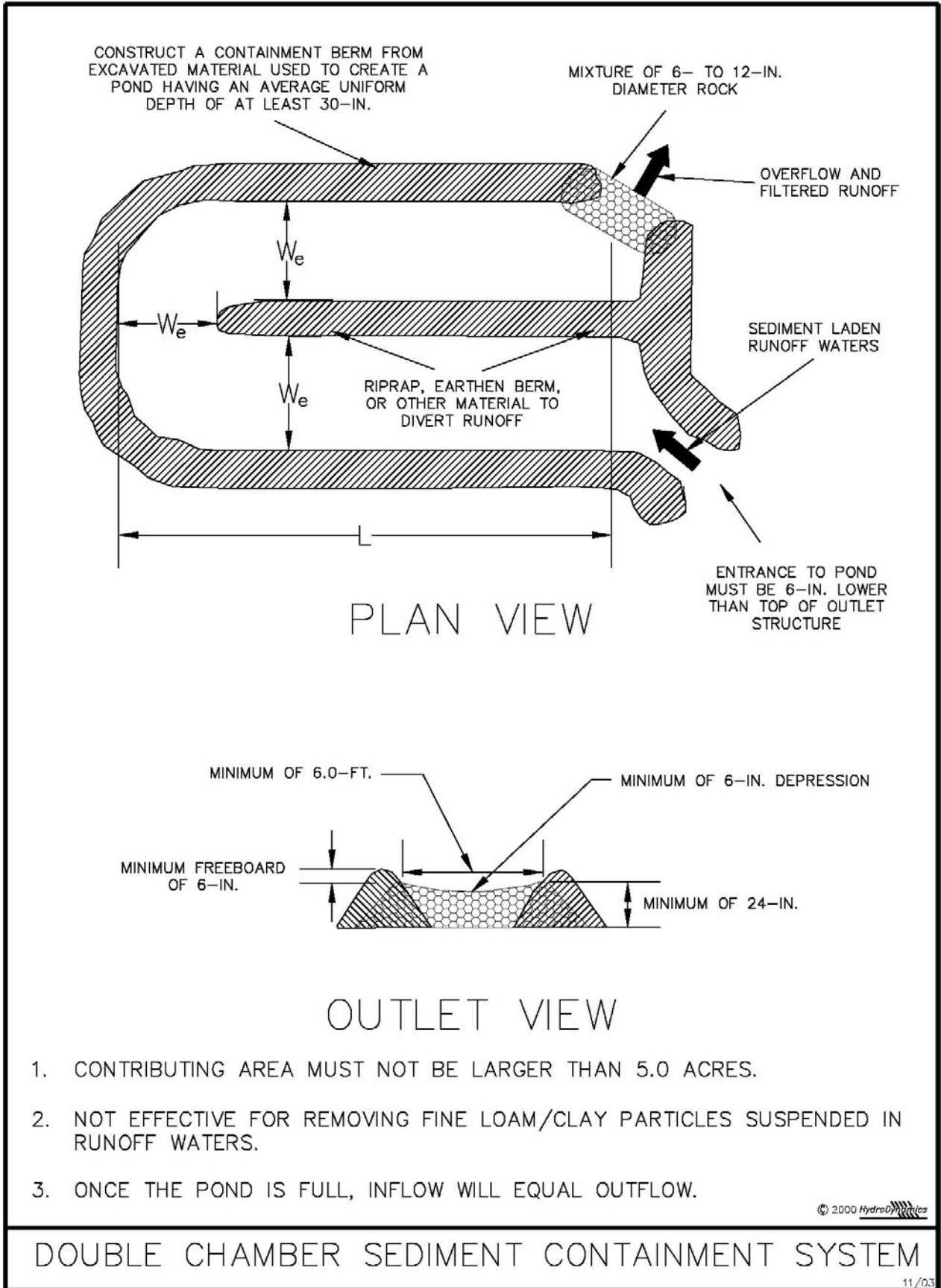

**Figure IV-14: Illustration of a Double Chamber SCS**

Permission is given by HydroDynamics Incorporated to copy and reproduce this detail

### Sediment Containment System Barrier for Culvert

#### **WHAT IS ITS PURPOSE?**

To reduce inflow velocity so that deposition of suspended particles found in runoff can occur upstream of the barrier.

#### **WHERE AND HOW IS IT COMMONLY USED (SEE FIGURE IV-14)?**

- On the upstream side of culverts.
- As part of a sediment containment system.

#### **WHEN SHOULD IT BE INSTALLED?**

- Before construction activities begin.
- While construction activities are occurring.

#### **WHEN SHOULD IT NOT BE INSTALLED?**

- After grading activities are completed.
- If it appears they will interfere with the discharge of major runoff.

#### **WHAT NEEDS TO BE INSPECTED?**

- Does water flow through the rock?
- Is the rock full of sediment?
- Is the right sized rock used?
- Is the barrier placed far enough away from the pipe opening?

#### **WHAT MAINTENANCE ACTIVITIES CAN BE EXPECTED?**

- Replacement of rock.
- Removal of sediment.

#### *Notes*

- Installation of a fabric that does not become clogged with clay and silt particles that impact the material's permeability might be adequate for use in place of a rock barrier.

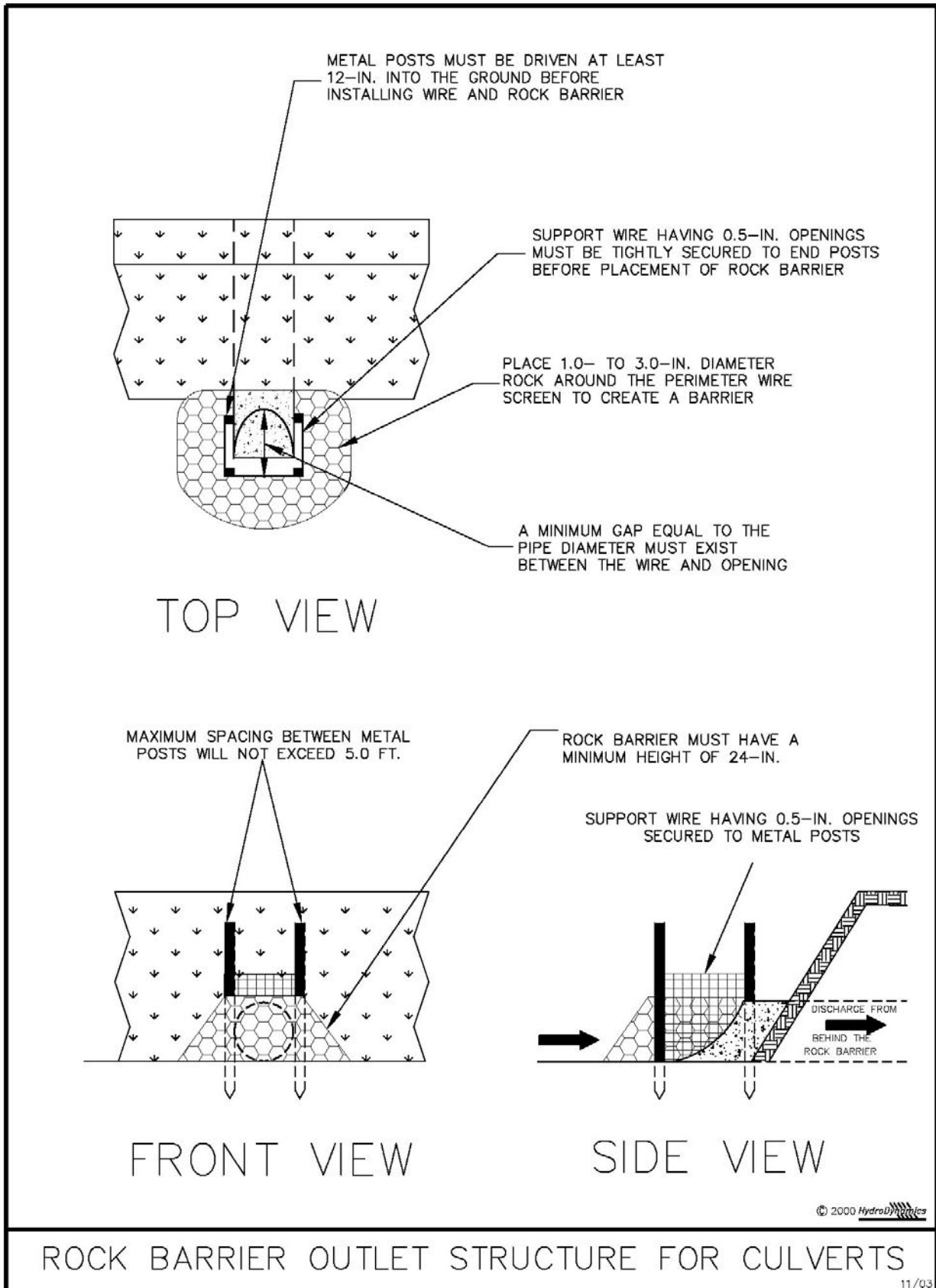

Figure IV-15: Illustration of a Rock Barrier Structure for Culverts

### Sediment Containment System Filter Bag

#### **WHAT IS ITS PURPOSE?**

To remove larger diameter size particles from sediment-laden waters by filtration.

#### **WHERE AND HOW IS IT COMMONLY USED (SEE FIGURE IV-15)?**

- Removing water collected behind cofferdams.
- Small ponds on construction sites.
- Removing water collected behind water barriers.
- Use in dewatering operations.

#### **WHEN SHOULD IT BE INSTALLED?**

- Prior to pumping contained water captured behind a barrier.
- Prior to pumping operations associated with dewatering activities.
- While construction activities are occurring.

#### **WHEN SHOULD IT NOT BE INSTALLED?**

- After grading activities are completed.

#### **WHAT NEEDS TO BE INSPECTED?**

- Overall appearance of the filter bag?
- Are there any tears or damage to the filter bag?
- Is the filter bag filled with sediment?
- Is the filter bag draining properly?
- Does water discharging from the bag flow away from water bodies?

#### **WHAT MAINTENANCE ACTIVITIES CAN BE EXPECTED?**

- Removal of accumulated sediment.
- Removal of the bag.
- Repair to damaged parts of bag.



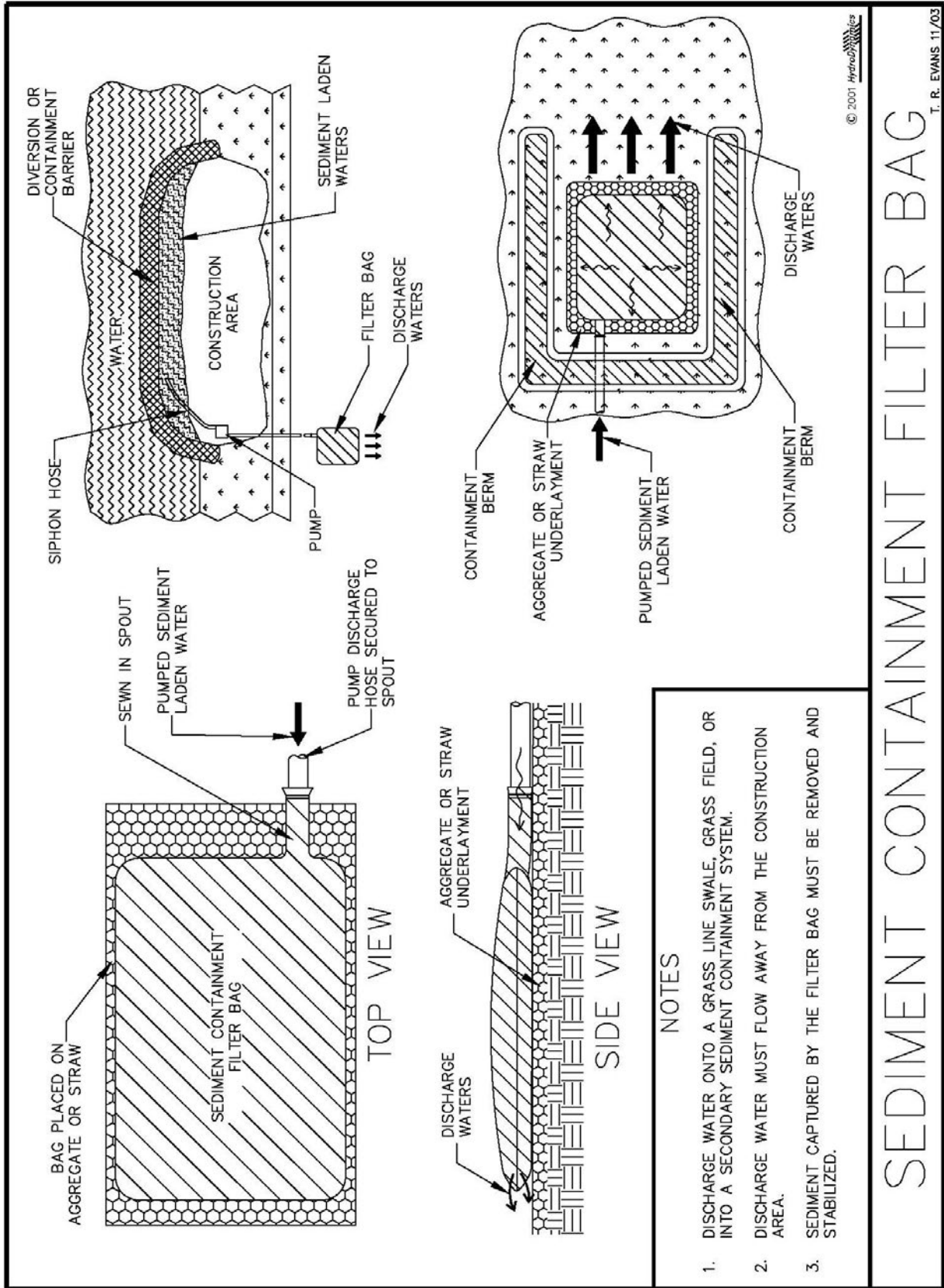

**Figure IV-16: Illustration of a Sediment Containment System Filter Bag**

Permission is given by HydroDynamics Incorporated to copy and reproduce this detail

### ***Use of Polymers or Alum***

When polymers or alum are added in correct amounts to sediment-laden waters, suspended colloidal particles combine resulting in an increased mass that is subject to acceleration by gravity through the water column. However, designers need to be aware that polymers or alum may be detrimental to aquatic life if introduced in inappropriate quantities or not properly selected for site conditions. For example, only cationic charged polymers can adhere to the gills of fish and may cause suffocation if not properly evaluated and introduced into contained waters. Anionic polymers do not adhere to fish gills. More detailed information about the use of polyacrylamides, dual-polymers and alum appears in Appendix III.

If the erosion of contributing soils results in runoff having suspended clay colloidal particles, properly introducing the use of polymers into these waters may dramatically reduce the size of a SCS, perhaps down to a pre-sedimentation basin. More importantly, proper use of polymers may assist in ensuring discharge waters from construction sites do not exceed Florida's water quality standard of 29 (or less) NTUs above background conditions. If suspended particles are not clay colloidal particles, then the Designer may require more detailed analyses if other chemicals (e.g., alum) may have to be introduced into runoff waters to achieve deposition (see Appendix III).

#### **Steps for Introducing Polymers into Runoff Waters**

If polymers are to be used to increase the efficiency of an SCS, it is important that Designers complete the following steps:

##### ***Step 1: Select Polymers Using Performance Based Standards***

Obtain representative soil and water samples from the active construction site and have them tested for a polymer that demonstrates superior removal capacity of suspended particles found in runoff waters. Tests need to demonstrate that within 60 seconds; at least 95% of all sediment and suspended colloidal particles found in 29-inch (735 mm) high vertical water column are captured and accelerating downward. More than likely, performance-based tests will have to be completed while construction activities continue to ensure optimal capturing capabilities of the polymer remains viable.

##### ***Step 2: Determine Design Inflow Values and Accompanying Polymer Concentration***

Sediment yields will vary depending upon the amount of land not protected against erosion as well as the magnitude of rainfall. Thus, it is important that Designers fully evaluate anticipated flows in drainage ditches and storm sewer systems that discharge into a SCS.

Specific frequency storm events are a norm for designing a detention pond or selecting the size of an inlet opening. The EPA emulated this requirement by specifying that when 10-acres or more of land is disturbed, a sediment containment system is to capture runoff resulting from a 2-year, 24-hour storm event. As a minimum, FDEP requires that once 10-acres or more of land are disturbed, at least 1-inch of runoff per unit area is to be contained (i.e. 3,600 cubic feet per disturbed upstream acre).

At each major inflow location (e.g. pipe, drainage swale, etc.) to a SCS, it is important that Designers determine flow rates resulting from at least a 2-year, 24-hour frequency storm event. More stringent requirements may be imposed by different regulatory agencies. It is at these inflow locations where the introduction of polymers is to occur in a manner (using manufacturer's specifications) that ensures optimal mixing.

*Step 3: Determine Anticipated Sediment Yields*

Figure IV-8 through Figure IV-11 provide charts to calculate anticipated sediment yields for 100% bare ground conditions assuming Hydrologic Type A through Hydrologic Type D soils, respectively. These values were calculated using the Modified Universal Soil Loss Equation (MUSLE) (Williams, 1976) as customized by Fifield (2004) and can be adjusted for different erodibility (i.e.  $K$ -Factor) values to reflect site conditions.

*Step 4: Complete Sizing of the Pre-Sedimentation (a.k.a. forebay) Basin*

When proper selection of a polymer is done, it is possible for nearly 100% of the suspended and colloidal particles to settle out of the runoff waters when design storm events occur. However, when these particles settle to the bottom of a detention/retention pond or lake, the possibility exists that infiltration properties will be compromised. Fortunately, development of a properly sized pre-sedimentation (a.k.a. forebay) basin to capture deposited material can overcome this potential problem.

Sediment Retention Barriers Using Polymers

Appendix III illustrates a different SCS from above, namely Sediment Retention Barriers (SRB). These structures are placed around area (a.k.a. catch basin) drains to treat sediment-laden runoff waters.

As discussed in Appendix III, SRBs can consist of a double row of silt fence barriers placed about 4- to 6-feet apart. Loose mulch, straw, woodchips, or other organic matter is mixed or blended with the site-specific polymer and placed between the silt fence barriers. The polymer within the mulch reacts with the suspended sediments, binding them into large particles that are trapped within the material.

Failure of these SRBs will occur if they are not installed correctly. Some specific items Designers need to address in their SWPPP include the following:

1. Selection of silt fence fabric material must be made to ensure passage of runoff waters will allow inflows to equal outflows. This implies that the standard woven or needle punched silt fence materials often found on construction sites will not be adequate. A minimum suggested permeability value of silt fence material is  $75 \text{ gpm/ft}^2$ .
2. Silt fence barriers will require diagonal bracing and wire backing to prevent collapsing of the structure.
3. Site selection of an SRB must be made to ensure sufficient containment volume exists around the structure to allow for temporary storage of inflow waters for a proposed design storm event.
4. Inspection and maintenance of SRBs is critical to ensure free passage of contained runoff waters.

It is important that Designers work with professionals that are experienced in using polymers on construction sites. In this manner, potential environmental problems can be professionally addressed and problems avoided.

### Using Alum to Remove Sediment from Runoff Waters

Some sediment found in runoff waters will not react with polymers (e.g. coral), but may react with alum. The use of alum within an erosion and sediment control plan will require the use of a properly designed sediment containment system.

Once alum has been identified as an option in a stormwater retrofit project, extensive laboratory testing must be performed to verify the feasibility of alum treatment and to establish process design parameters. The feasibility of alum treatment for a particular construction activity related stormwater stream is typically evaluated in a series of laboratory jar tests conducted on representative runoff samples collected from the project watershed area.

Alum treatment requires close monitoring of dosages since overdosing may be harmful. In addition, alum may result in lowered pH and elevated levels of  $Al^{+3}$  if improperly applied. As with using polymers, it is important that Designers work with professionals that are experienced in using alum on construction sites. In this manner, potential environmental problems can be professionally addressed and problems avoided. Additional information on the use of alum appears in Appendix III.

## **EXAMPLES**

***SCS Effectiveness of an Existing Pond***

When a detention/retention pond is to be part of the development, it should be one of the first items constructed and converted into an effective SCS. As an example, consider a site having the following parameters for a land development project in Orange County, Florida where predominate soil types are Smyrna loamy fine sands.

- Contributing Basin = 18.5 Acres
- Maximum Surface Area of Pond = 12,800 Square Feet
- Flow Path within Pond = 200 Feet
- Average Pond Width = 64 Feet

If a SCS is to be effective it must meet criteria that ensure an efficient system exists. The following steps illustrate how this is accomplished:

*Step 1: Complete a PEG Soils Analyses*

Usually, when development occurs, soil analyses of contributing lands are routine; however, in the event that such data are not available, cursory values can be obtained from the Natural Resource Conservation Service (NRCS) by consulting their soil surveys. Assume for this example that data obtained from the NRCS survey resulted in development of the graph shown at the right.

The PEG graph of Smyrna loamy fine sands demonstrates that about 90% of particles have diameters that are about 0.075 mm (0.003-in.) and larger. This indicates that at least 10% of the suspended particles entering the pond will be smaller than 0.075 mm (0.003-in.). More than likely, turbidity values associated with runoff waters can be related to particles having diameters smaller than 0.075 mm (0.003-in.).

For this example, we will consider our design size particle to have a diameter of 0.075 mm (0.003-in.).

*Step 2: Evaluate how Surface Area Varies with Discharges*

For this exercise, our design size particle for the SCS calculations will remain at 0.075 mm (0.003-in.). Using equations found in Table IV-2, we see that a minimum surface area (square feet) of a pond is calculated by:

$$SA_m = (1.2 \times Q_{out}) \div V_s$$

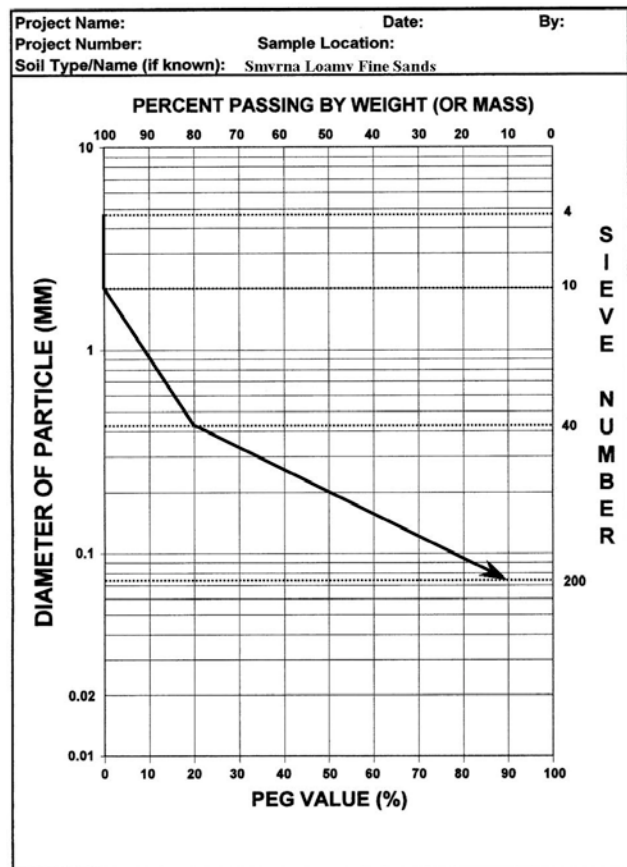

From Table IV-3, a 0.075 mm (0.003-in.) diameter particle will have a settling velocity of about 0.01107 ft. /sec. at a water temperature of 50 degrees Fahrenheit. Notice that settling velocities of suspended particles become less in colder water due to greater fluid viscosity. Conversely, settling velocities increase for warmer waters. *Designers should always select a representative cold-water temperature when designing a SCS to ensure greater capture of suspended particles when warmer inflow water conditions exist.*

From Table IV-2, we see that:

$$SA_m = (1.2 \times Q_{out}) \div V_s = (1.2 \times Q_{out}) \div 0.011 = 109 \times Q_{out} \quad (\text{square feet})$$

Since minimum surface area of the pond is dependent upon the discharge from the system, the above equation allows for development of the following table to evaluate what pond surface areas must exist if capturing 0.075 mm (0.003-in.) diameter particles is feasible for different outflows:

Discharge (ft. <sup>3</sup> /sec.)	Surface Area (ft. <sup>2</sup> )
10	1,090
20	2,180
30	3,270
40	4,360
50	5,450

The above table demonstrates for large discharge values that the existing pond surface area of 12,800 square feet is more than adequate for capturing suspended 0.075 mm (0.003-in.) diameter particles. Now the only question lies with determining a pond effectiveness to capture design size and larger, particles by gravitational means.

*Step 3: Calculate the Apparent Effectiveness of the System to Capture Design Size Particles*

Using the above information, it is found that  $L/W_e$  ratio is 200 feet  $\div$  64 feet = 3.1. By using Figure IV-1, the following graph illustrates the apparent effectiveness of this pond to capture 0.075 mm (0.003-in.) and a larger diameter particle is about 52%.

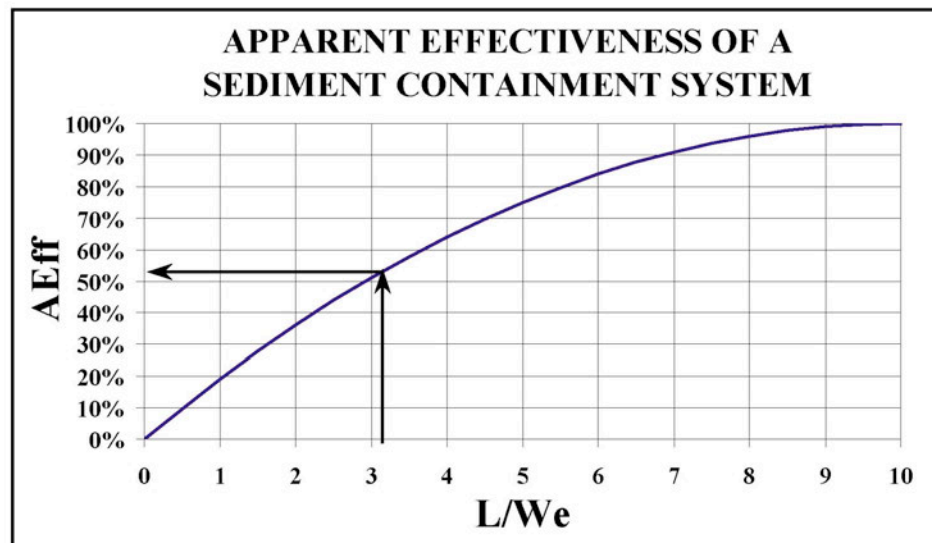

*Step 4: Calculate the Net Effectiveness of the System*

The  $AEff$  value of 52% gives an indicator of effectiveness for the existing pond to capture design size and larger particles associated with inflows of runoff from contributing lands, assuming terminal velocity conditions exist. However, this value does not represent the net effectiveness of a SCS to remove all suspended particles.

Earlier, we found that about 90% of the contributing land particles (i.e.  $PEG = 90\%$ ) are 0.075 mm (0.003-in.) and larger. Therefore, the net effectiveness (see Table IV-2) of this pond to capture suspended design size particles of 0.075 mm (0.003-in.) and larger is:

$$NEff = AEff \times PEG = 52\% \times 90\% = 46.8\%$$

While this pond may capture about 47% of the particles that are 0.075 mm (0.003-in.) and larger, it still will release nearly  $100\% - 47\% = 53\%$  of all incoming sediments when discharge occurs.

***Sizing a Dewatering SCS***

Dewatering activities need to occur to reduce the ground water level for construction activities. It has been decided that pumping rates will vary from 125 to 300 gallons per minute ( $gpm$ ). In order to maximize the treatment of waters, the Designer has decided a SCS structure should have a length to width ratio of at least 7.0 with the pumped water being discharged into a double chamber system (see Figure IV-14):

*Step 1: Decide Upon a Design Size Particle to Treat.*

Since no information about the size of suspended particles exist, assume treatment will be for a 0.02 mm (0.0008-in.) diameter particle when ground water has a temperature of 60°F.

*Step 2: Determine the Settling Velocity and Range of Discharge Values.*

From Table IV-3, a 0.02 mm (0.0008-in.) particle will fall through 60°F water at about 0.00105 ft./sec.

$$125 \text{ gallons per minute} = 125 \text{ gpm} \times 0.00228 \text{ cfs/gpm} = 0.29 \text{ cfs}$$

$$\text{and } 300 \text{ gpm} = 0.68 \text{ cfs.}$$

*Step 3: Calculate and Decide Upon the Minimum SCS Pond Surface Area.*

$$SA_m = (1.2 \times Q_{out}) \div V_s = (1.2 \times 0.29) \div 0.00105 = 331 \text{ ft.}^2$$

and

$$SA_m = (1.2 \times Q_{out}) \div V_s = (1.2 \times 0.68) \div 0.00105 = 777 \text{ ft.}^2$$

The Designer decides to be conservative and uses 800 ft.<sup>2</sup>

*Step 4: Calculate the Remaining Parameters.*

$$L = [(L \div W_e) \times SA_m]^{0.5} = [7.0 \times 800]^{0.50} = 75 \text{ feet}$$

$$W_e = SA_m \div L = 800 \div 75 = 11 \text{ feet}$$

$$D_{avg} \geq 2.2 \text{ ft.}$$

$$VOL_m \geq 2.2 \times SA_m \geq 2.2 \times 800 \geq 1,760 \text{ ft.}^3$$



*Step 5: Since a Double Chamber is to be used, Convert the Length and Width Values.*

From Page IV-26,  $L_{\text{final}} = \frac{1}{2} \times L = 37.5$  feet long. Thus, each chamber in the temporary SCS should be about 37.5 feet long, 11 feet wide, and have an average depth of around 2.2 feet.

Additional information on dewatering methods appears in Appendix II.

### ***Builder Pre-Sedimentation Basin***

A builder purchases 15 acres of re-vegetated land from a developer on which 50 condominiums will be built. The land has an average slope ( $V: H$ ) of 0.50% with approximately 10% held in a natural condition.

The development is located within Hydrologic Type B soils having an erodibility factor of 0.24. Assuming a polymer is introduced into the storm drain system, determine the size of a pre-sedimentation basin constructed at the outfall of the storm sewer system to treat runoff due to a 2-year, 24-hour storm event of 3.50 inches.

*Step 1: Determine the Amount of Land that will be Under Construction.*

Different land disturbing scenarios can exist depending upon how the builder wants to construct the condominiums. However, a worse case scenario exists when all the possible land is being disturbed.

$$A = 15 \text{ acres} - (10\% \text{ of } 15 \text{ acres}) = 13.5 \text{ acres}$$

*Step 2: Determine the Sediment Yield.*

From Figure IV-8,  $LR = 46$  cubic feet/acre<sup>1.12</sup> when a 2-year, 24-hour storm event occurs on a watershed with a 0.50% ( $V: H$ ). Notice that the chart erodibility value is  $K = 0.30$ , but the site erodibility value is 0.24. Thus, it is necessary to adjust the LR value.

$$\text{Sediment Yield} = (0.24 \div 0.30) \times 46 \times 13.5^{1.12} = 679 \text{ cubic feet}$$

*Step 3: Determine the Pre-Sedimentation Basin Parameters.*

$$\text{Surface Area} = 0.67 \times 679 = 455 \text{ square feet}$$

$$\text{Length} = 3.79 \times (455)^{0.5} = 81 \text{ feet}$$

$$\text{Width} = 0.10 \times 81 = 8 \text{ feet}$$

$$\text{Depth} = 18 \text{ in.} = 1.5 \text{ ft. (recommended minimum depth)}$$

Thus, creating a structure at the storm sewer discharge pipe that is at least 81 feet long, about 8 feet wide, and 18 inches deep will serve as a pre-sedimentation basin.

### ***Linear Road Pre-Sedimentation Basin***

A highway project contractor has to ensure runoff waters from about 5.0 acres of disturbed lands that flows through a drainage ditch before discharging into a river will meet 29 NTUs above background conditions when a storm event of 2.75 inches occur.

The Designers completed an analysis of the area and concluded the following:

- The average slope of contributing lands is about 2.50% (2.5 feet  $V$ : 100 feet  $H$ ).
- Contributing lands are Hydrologic Type C soils with  $K = 0.40$

Assume tests indicate that the addition of a polymer within the drainage channel will provide conditions to remove nearly 100% of the suspended colloidal particles, determine the parameters of an “in-line” temporary sedimentation basin.

*Step 1: Determine the Sediment Yield.*

When 2.75 inches of rain falls on a bare ground slope of 2.50%, then  $LR = 210 \text{ cu. ft/ac}^{1.12}$  and

$$\text{Sediment Yield} = (0.40 \div 0.43) \times 210 \times 5.0^{1.12} = 1,185 \text{ cubic feet}$$

*Step 2: Calculate the Temporary Sedimentation Basin Parameters.*

$$\text{Surface Area} = 0.67 \times 1,185 = 794 \text{ square feet}$$

$$\text{Length} = 3.79 \times (794)^{0.5} = 106 \text{ feet}$$

$$\text{Width} = 0.10 \times 106 = 11 \text{ feet}$$

$$\text{Depth} = 1.5 \text{ feet}$$

Thus, when sufficient polymer is continually introduced into runoff waters discharging from 5.0 acres of disturbed lands, a pre-sedimentation basin about 106 feet long, 11 feet wide, and 18 inches deep is required. It may be adequate to place the SCS in line with the drainage swale to capture anticipated sediment loads caused by a 2.75-inch (and smaller) storm event.

**SECTION V**  
**TEMPORARY CONSTRUCTION SITE BMPs**

## Table of Contents

<b>INTRODUCTION .....</b>	<b>1</b>
<b>USING BARRIERS TO REMOVE SEDIMENT FROM RUNOFF WATERS.....</b>	<b>1</b>
LIMITATION OF BALE BARRIERS .....	1
SILT-FENCE BARRIERS.....	2
FIBER LOGS .....	2
TEMPORARY COMPOST BERMS .....	2
AREA-DRAIN (A.K.A. DROP, CATCH BASIN, OR DITCH BOTTOM) INLET BARRIERS .....	2
BARRIERS FOR STORM SEWER CURB INLET OPENINGS .....	3
<i>Curb and Gutter Sediment Containment System</i> .....	4
<i>Inlet Inserts</i> .....	4
<i>Cellular Confinement Systems</i> .....	4
USING POLYMERS TO INCREASE SEDIMENT REMOVAL FROM RUNOFF WATERS .....	5
USING BMPs WHEN BUILDING BOX CULVERTS.....	47
<b><u>Summary Sheets for Sediment Control BMPs</u></b>	
<b>Silt Fence Barrier.....</b>	<b>6</b>
<b>Fiber Log Barriers for Individual Lots.....</b>	<b>8</b>
<b>Continuous Berm Barrier .....</b>	<b>16</b>
<b>Geosynthetic Barrier .....</b>	<b>20</b>
<b>Turbidity Barrier .....</b>	<b>Error! Bookmark not defined.</b>
<b>Water Filled Barrier .....</b>	<b>26</b>
<b>Rock Barrier for an Area Drain (a.k.a. Drop, Catch Basin, or Ditch Bottom) Inlet.....</b>	<b>31</b>
<b>Frame &amp; Filter Barrier for Area Drain (a.k.a. Drop, Catch Basin, or Ditch Bottom) Inlets .....</b>	<b>33</b>
<b>Curb Inlet “Sump” Barrier.....</b>	<b>35</b>
<b>Curb Inlet Diversion Berm .....</b>	<b>37</b>
<b>Curb and Gutter Sediment Containment System Detail.....</b>	<b>39</b>
<b>Curb Inlet Insert .....</b>	<b>41</b>
<b>Soil Tracking Prevention Device .....</b>	<b>43</b>
<b>Cellular Confinement System .....</b>	<b>45</b>

## Table of Figures

FIGURE V-1:	HOW BARRIERS AROUND AREA DRAINS ON A GRADE FAIL DURING RUNOFF EVENTS	3
FIGURE V-2:	ILLUSTRATION OF A SILT FENCE BARRIER .....	7
FIGURE V-3:	ILLUSTRATION OF FIBER LOG BARRIERS FOR INDIVIDUAL LOTS .....	15
FIGURE V-4:	ILLUSTRATION OF A CONTINUOUS BERM BARRIER .....	19
FIGURE V-5:	ILLUSTRATION OF A GEOSYNTHETIC BARRIER .....	21
FIGURE V-6:	ILLUSTRATION OF A TURBIDITY BARRIER CURTAIN. <b>ERROR! BOOKMARK NOT DEFINED.</b>	
FIGURE V-7:	ILLUSTRATION OF A WATER FILLED BARRIER.....	30
FIGURE V-8:	ILLUSTRATION OF ROCK BARRIERS AROUND AREA DRAINS .....	32
FIGURE V-9:	ILLUSTRATION OF A FRAME & FILTER BARRIER FOR AREA DRAINS .....	34
FIGURE V-10:	ILLUSTRATION OF A CURB INLET "SUMP" BARRIER.....	36
FIGURE V-11:	ILLUSTRATION OF A CURB INLET DIVERSION BERM .....	38
FIGURE V-12:	ILLUSTRATION OF A CURB AND GUTTER SEDIMENT CONTAINMENT SYSTEM .....	40
FIGURE V-13:	ILLUSTRATION OF AN INLET INSERT SEDIMENT CONTAINMENT SYSTEM .....	42
FIGURE V-14:	ILLUSTRATION OF A SOIL TRACKING PREVENTION DEVICE .....	44
FIGURE V-15:	ILLUSTRATION OF USES FOR CELLULAR CONFINEMENT SYSTEMS.....	46
FIGURE V-16:	ILLUSTRATION OF USING BMPs WHILE BUILDING BOX CULVERTS.....	49

## **INTRODUCTION**

Examples of sediment control methods commonly found on construction sites are barriers. These structures are usually inexpensive and easy to install. Also, since their effectiveness is minimal for large runoff events, they do not require the detailed design needed for sediment containment systems. However, they are expensive Best Management Practices (BMPs) to use when considering the need for frequent maintenance.

## **USING BARRIERS TO REMOVE SEDIMENT FROM RUNOFF WATERS**

A barrier is any structure that obstructs or prevents the passage of water. If runoff cannot pass through a barrier, then water will either be contained or flow over the structure. Consequently, small sediment barriers may function as a small SCS or as a method to reduce flow velocity.

Some examples of commonly used sediment barriers are:

- Silt fences
- Belted Strand Reinforced Silt Fences
- Inlet barriers
- Staked turbidity barriers
- Diversion barriers

Appropriate places for sediment barriers are:

- Along sections of a site perimeter
- Below disturbed areas subject to sheet and rill erosion
- Below the toe of exposed and erodible slopes
- Along the toe of stream and channel banks
- Around area drains or inlets located in a “sump” when properly supported
- Downstream edge of areas undergoing vertical and/or big box construction activities

Inappropriate places for sediment barriers include:

- Parallel to a hillside contour
- In channels where concentrated flows occur, unless properly reinforced
- Upstream or downstream of culverts where concentrated flows occur
- In front of or around inlets on a grade where concentrated flows occur
- In flowing streams

Illustrations of different barriers commonly used on construction sites appear in Summary Sheets and associated Figures within this section.

### ***Limitation of Bale Barriers***

Use of straw or hay bales has traditionally been one of the more popular methods used in trying to reduce sediment from construction sites. Unfortunately, their widespread use does not justify the fact that they are relatively ineffective. It is for this and other reasons that the FDOT does not allow use of straw or hay bale barriers on construction sites.

### ***Silt-Fence Barriers***

Silt (also known as sediment) fence barriers consist of geosynthetic material placed in a manner that controls **sheet flow** from disturbed lands (see Figures V-2 through V-4). Except for very large diameter (e.g. sand) particles, silt fences do not "filter" sediment out of runoff waters. Instead, the effectiveness of a silt fence is dependent upon its ability to create a small "containment system" to allow for deposition of suspended particles.

If a silt fence is to be successful in removing sediment from runoff waters, installation must occur in a manner that allows for the deposition of suspended particles. Consequently, proper installation and continued maintenance is essential.

### ***Fiber Logs***

Fiber logs (a.k.a. fiber rolls or wattles) are beginning to be used more extensively on construction sites. These tightly bound "logs" of material (see Figure V-5) must be viewed as a barrier that is simulating bales. As such, they must be installed correctly, will require extensive maintenance, and have limited use.

Installing fiber logs along hillsides will provide a temporary erosion control BMP. However, proper seeding and mulching will be more effective in stabilizing disturbed slopes. Usually, fiber logs should not be used in drainage channels since they will be impacted by large flows. However, their use on vertical and/or big box construction sites might be appropriate where small runoff events occur.

### ***Temporary Compost Berms***

Temporary compost berms are commonly found where runoff sheet flows from a site. Examples include at the base of hills and along the downstream edges of lots where homes are being built.

Typical berm materials include shredded wood (wood chips, wood bark, wood cellulose fiber, and wood excelsior) and "green" material (vegetative trimmings such as grass, shredded shrubs, and trees).

Tests in Texas have shown compost berms do not have much resistance to failure unless a root structure is found within the material. Thus, it is important that when these containment systems are installed, vegetation be established as soon as possible.

### ***Area-Drain (a.k.a. Drop, Catch Basin, or Ditch Bottom) Inlet Barriers***

Placing barriers around an area drain or drop inlet must be avoided unless it is located in a low area that receives runoff from surrounding lands (i.e. in a "sump"). When the drain is located on a grade, runoff diverted by the barrier might cause significant downstream flooding problems as depicted in Figure V-1.

When not in a sump condition, placing barriers upstream of the structure and across a drainage channel perpendicular to the flow should be considered. The barriers will create a SCS and the drainage system will continue to remove runoff waters to reduce the potential of downstream flooding. Attention should be given to the surrounding topography and placement of the upstream barrier so that runoff waters flow over, and not around, the structure.

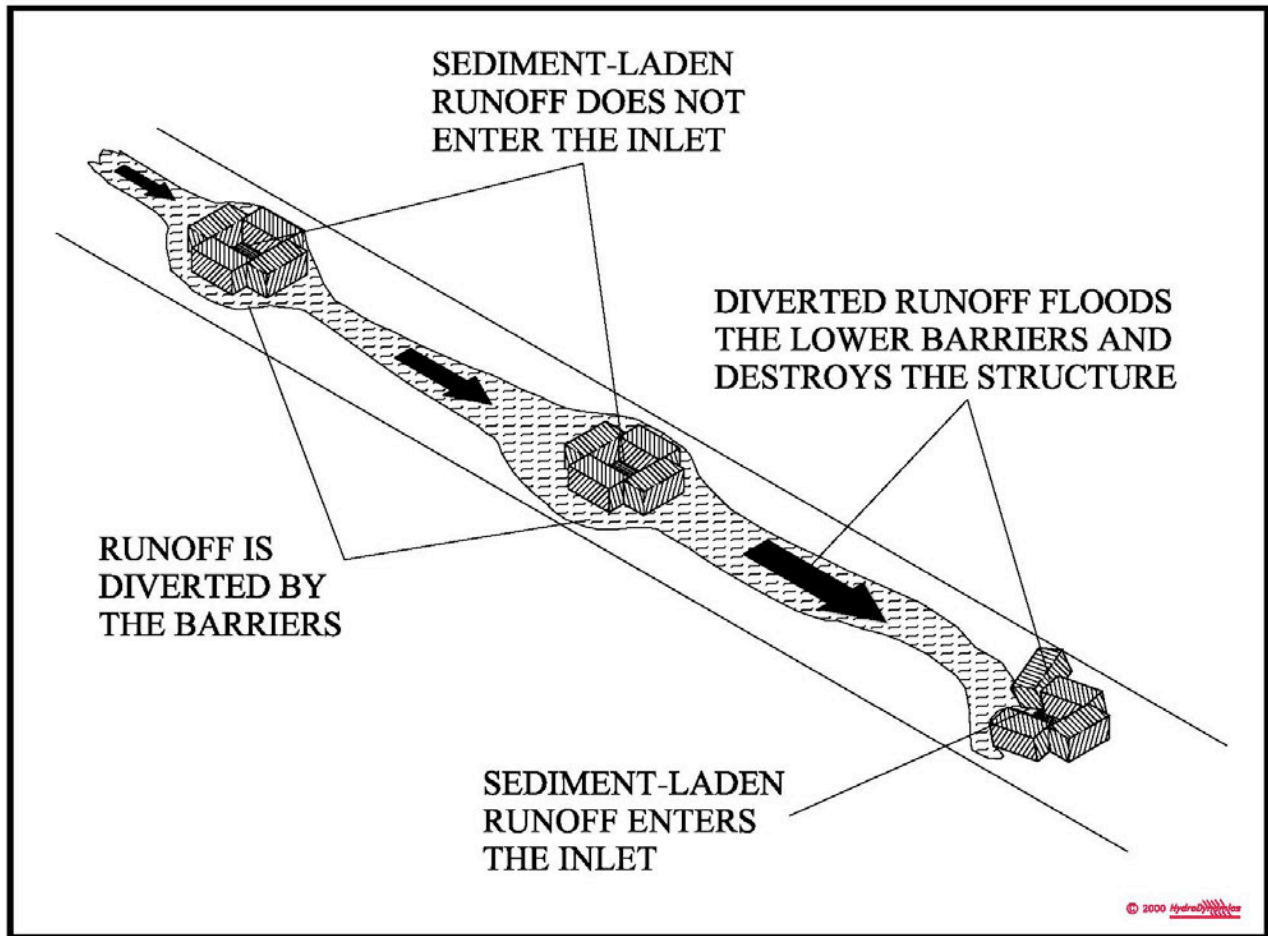

**Figure V-1: How Barriers Around Area Drains on a Grade Fail During Runoff Events**

When sump conditions exist, various methods exist to allow for ponding of runoff. For example, installing rock or fabric filter (having adequate support) barriers or placing a fiber log having a height of at least 12-inches might be alternatives. However, use of silt fence barriers is *not recommended* unless properly installed and supported.

***Barriers for Storm Sewer Curb Inlet Openings***

Placing rock barriers in front of inlets where street grades exist prevents the capturing of flows in gutters. Once runoff waters are prevented from entering inlets, downstream flooding becomes a major problem.

Only when a curb inlet is at a sump location should placement of a rock or coral barrier in front of a curb inlet occur. Otherwise, the possibility of diverting runoff waters away from the inlet and causing downstream flooding exists. In addition, at no time should rock or coral completely cover the opening of an inlet. Finally, install warning signs to alert drivers about potential damage to vehicles.

The advantage of using rock or coral barriers at curb inlets is that they will drain and reduce ponding around the inlet when sump conditions exist. However, maximum efficiency will be



realized only by collecting runoff behind the barrier. Once runoff waters flow over the top and into the inlet, little sediment will be captured (Fifield, 1997).

A reported (by contractors) disadvantage of allowing runoff to pond in front of an inlet is the damage that often occurs to the pavement. As water seeps between the concrete and asphalt junction, structural integrity may become compromised and could cause damage to the road.

#### Curb and Gutter Sediment Containment System

Figure V-17 illustrates how placing rock or sand bags in a gutter flow line will create small SCS on streets having a grade. When properly installed, deposition of sediment will occur without compromising the role of an inlet to capture runoff waters in gutters.

One would think that rock bags are recommended over sand bags to allow for drainage. However, rock bags tend to be rigid whereas partially filled sand bags conform to the gutter system. In addition, rock bags tend to become clogged with sediment and function similar to sand bags, which is as barriers.

When installed in the gutter, bag tops must be lower than the curb height. As with all barriers, these systems will capture only a small amount of the total suspended particles found in runoff waters. Hence, they are more effective for small runoff events.

#### Inlet Inserts

During the grading phase of a project, it is advisable to install fabric under a grate or within a storm sewer opening to prevent soil from entering the system. However, these fabrics will become clogged and prevent the passage of water into a storm sewer system. As a result, once pavement is placed or developed conditions exist for vertical construction, localized flooding occurs.

Designers must clearly indicate on the E&SC plans that placing fabric material in a manner that totally blocks (e.g. under grates) runoff waters entering a storm sewer system will result in localized flooding. Inlet inserts overcome this problem by catching sediment but not preventing runoff from entering the storm sewer system. They are placed inside the inlet structure to treat incoming flows. Refer to Figure V-18 for more information on inlet inserts.

Inflow waters continually stir the captured soil before discharging into existing drainage pipes. Thus, only a small amount of the total suspended particles found in runoff waters are actually captured. However, the ability of an inlet to control drainage is not compromised. As with all SCSs, continual maintenance of the inserts must occur.

#### Cellular Confinement Systems

When conditions result in high flow values, it may be necessary to install cellular confinement systems. These rigid units can be installed on hillsides, in drainage ditches, as a soil tracking prevention device, or serve as temporary stream crossings. Each system has cells in which rock, soil, or cement can be placed. Once this occurs, increased stabilization exists creating a system that can withstand large loads while preventing erosion. Refer to Figure V-20 for additional information on cellular confinement systems.

***Using Polymers to Increase Sediment Removal from Runoff Waters***

Temporary sediment control measures by themselves are not very effective in removing sediment from runoff waters. However, their efficiency can increase by properly applying polymers. Some of these techniques include the following (see Appendix III):

1. Apply soil-specific polymer surrounding an area drain and cover the soil with a layer of jute fabric.
2. Install polymer logs inside and/or upstream of water conveyance devices to treat runoff after it has moved through a rock barrier.
3. Place the polymer logs so that runoff within a drainage channel having check structures will flow over and around them. The number of logs is determined by the flow rate of the water. Longer mixing times will have the best reduction of turbidity.
4. Cover rock check structures with jute fabric that has been applied with a site-specific polymer powder.

It is important that Designers work with professionals that are experienced in using polymers on construction sites. In this manner, potential environmental problems can be professionally addressed and problems avoided.

### Silt Fence Barrier

#### **WHAT IS ITS PURPOSE?**

Temporary sediment containment structures while construction activities occur.

#### **WHERE AND HOW IS IT COMMONLY USED?**

- At the toe of cut and fill slopes.
- As small containment systems.
- On downstream sides of lots.
- Protecting water bodies.

#### **WHEN SHOULD IT BE INSTALLED?**

- Before construction activities begin.
- While construction activities are occurring.

#### **WHEN SHOULD IT NOT BE INSTALLED?**

- Where concentrated flows are expected such as in drainage ditches, around inlets, and above/below where culverts discharge.
- After construction activities are completed.

#### **WHAT NEEDS TO BE INSPECTED?**

- Are stakes on the downstream side?
- Does water flow under the fabric?
- Has water "flattened" the structure?
- Is the fabric torn?
- Is the fabric secured in the ground?
- Is the fabric attached to posts?
- Will water flow around the fence?
- Has wind destroyed the fence?

#### **WHAT MAINTENANCE ACTIVITIES CAN BE EXPECTED?**

- Repair and replacement of material.
- Removal of sediment.
- Removal of fence material.

#### ***NOTES***

- Silt fence barriers are not to be used where concentrated flows of water are anticipated such as in drainage ditches, around inlets, or above/below where culverts discharge.
- When installed properly, silt fence barriers can create Type-2 sediment containment systems to allow for deposition of suspended particles, especially on vertical/big box construction sites.
- Silt fence barriers do not filter small-suspended particles in runoff waters.
- Using wire backing for support is discouraged due to disposal problems.
- Compacting trench fill material is very critical.

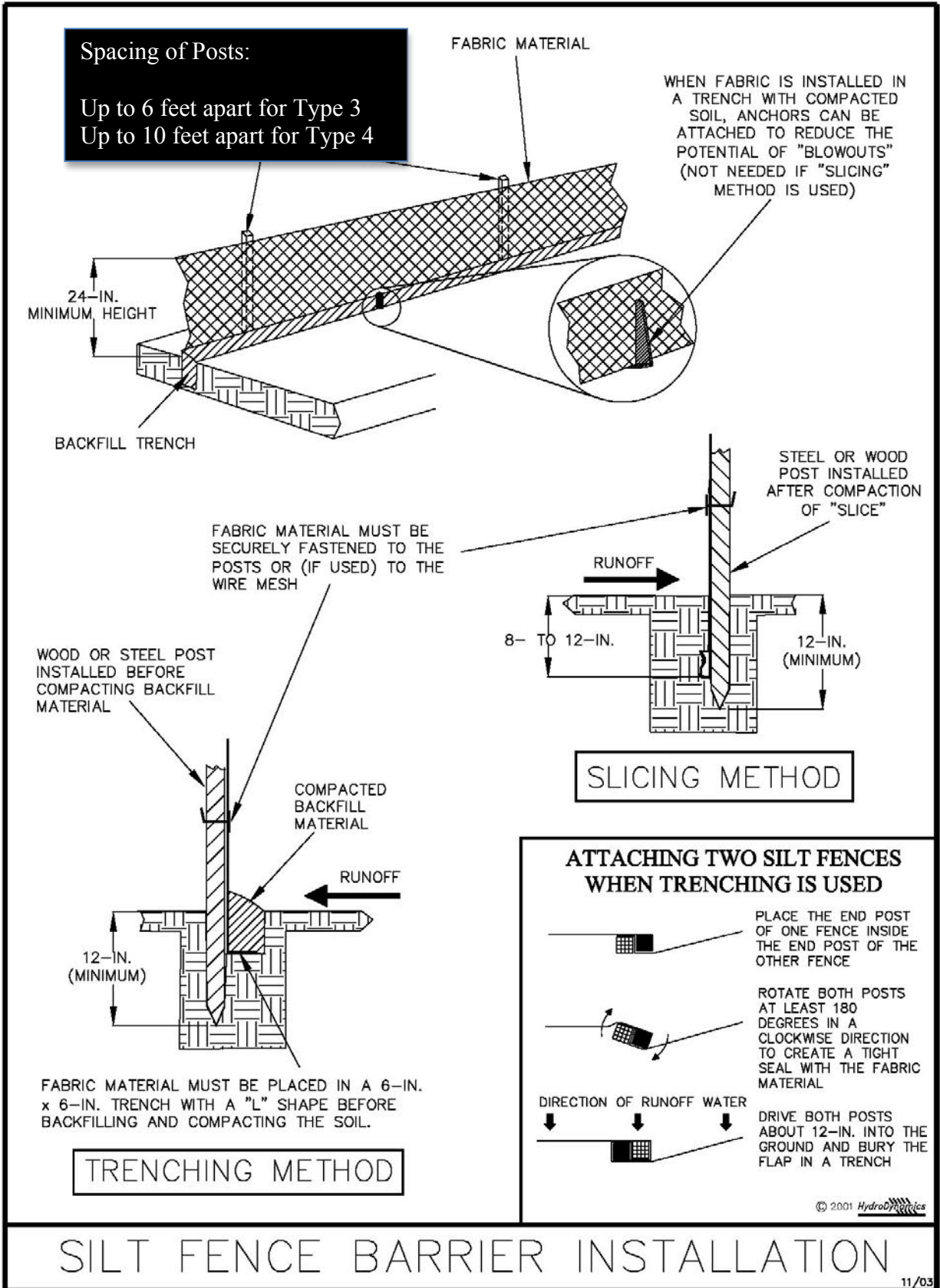

Figure V-2: Illustration of a Silt Fence Barrier

Permission is given by HydroDynamics Incorporated to copy and reproduce this detail

## Silt Fence Priority 2 (Black Band)

### **WHAT IS ITS PURPOSE?**

The Priority 2 Silt Fence shall be used as a vertical interceptor of sediment transported by overland *sheet flow* on construction sites. This silt fence is a 36-inch wide, non-woven, spun-bond polyester fabric. The system encompasses wood stakes and a specific method of attachment (see Installation Specifications in Notes below).

### **WHERE AND HOW IS IT COMMONLY USED?**

- At the toe of cut and fills slopes
- To protect water bodies.
- As a small sediment containment system
- To provide filtering capabilities in slurry conditions

### **WHEN SHOULD IT BE INSTALLED?**

- Before construction activities begin.
- It is designed for control of sheet flow.

### **WHEN SHOULD IT NOT BE INSTALLED?**

- Shall not be installed across streams, ditches, waterways, or anywhere there is concentrated flow.
- Shall not be placed around storm water inlets, which receive concentrate flow.

### **WHAT NEEDS TO BE INSPECTED?**

- Are stakes on the downstream side?
- Does water flow under the fabric?
- Has water flattened the structure?
- Is the fabric torn?
- Is the fabric secured correctly in the ground?
- Is the fabric attached to the posts?
- Will water flow around the fence?
- Has wind destroyed the fence?

### **WHAT MAINTENANCE ACTIVITIES CAN BE EXPECTED?**

- Regular inspection at the end of each workday and after each rainfall event.
- Remove the fence and accumulated sediment and stabilize the exposed area at completion of the project.
- Accumulated sediment should be removed when it reaches half the height of the fence to prevent failures.

## ***NOTES***

- The life of the product is determined at the point in which it is no longer effective or needed to do the job for which it is designed (Approximately one year).
- Installation Specifications: The method of installation for the Priority 2 Silt Fence is an integral part of the system and is unlike other installation practices. The specifically designed process includes wood (oak) stakes and wood bonding strips placed at six (6') foot intervals. The silt fence shall be installed in a trench 4" wide and 8" deep. Installation of trenches over 4" wide are not recommended. Stakes are driven to a depth, which allows 24" of fabric to be above ground. The bonding strips (typically 1" x 3/8" x 24") are attached to the stake with 1" x 1/4" staples. Four staples are used to secure the fabric in place against the 1 1/8" x 1 1/8" oak posts. This installation bonds the fabric to the vertical support post. The remaining fabric is now tucked into the trench forming a "J" and when filled with dirt creates a "ground bite". With its firm attachment to each post, the load is now spread to the total linear strength of all the posts within the system.
- *Any variance from the material specifications installation requirements may alter the performance of this product.* The product is available pre-staked to these specifications.

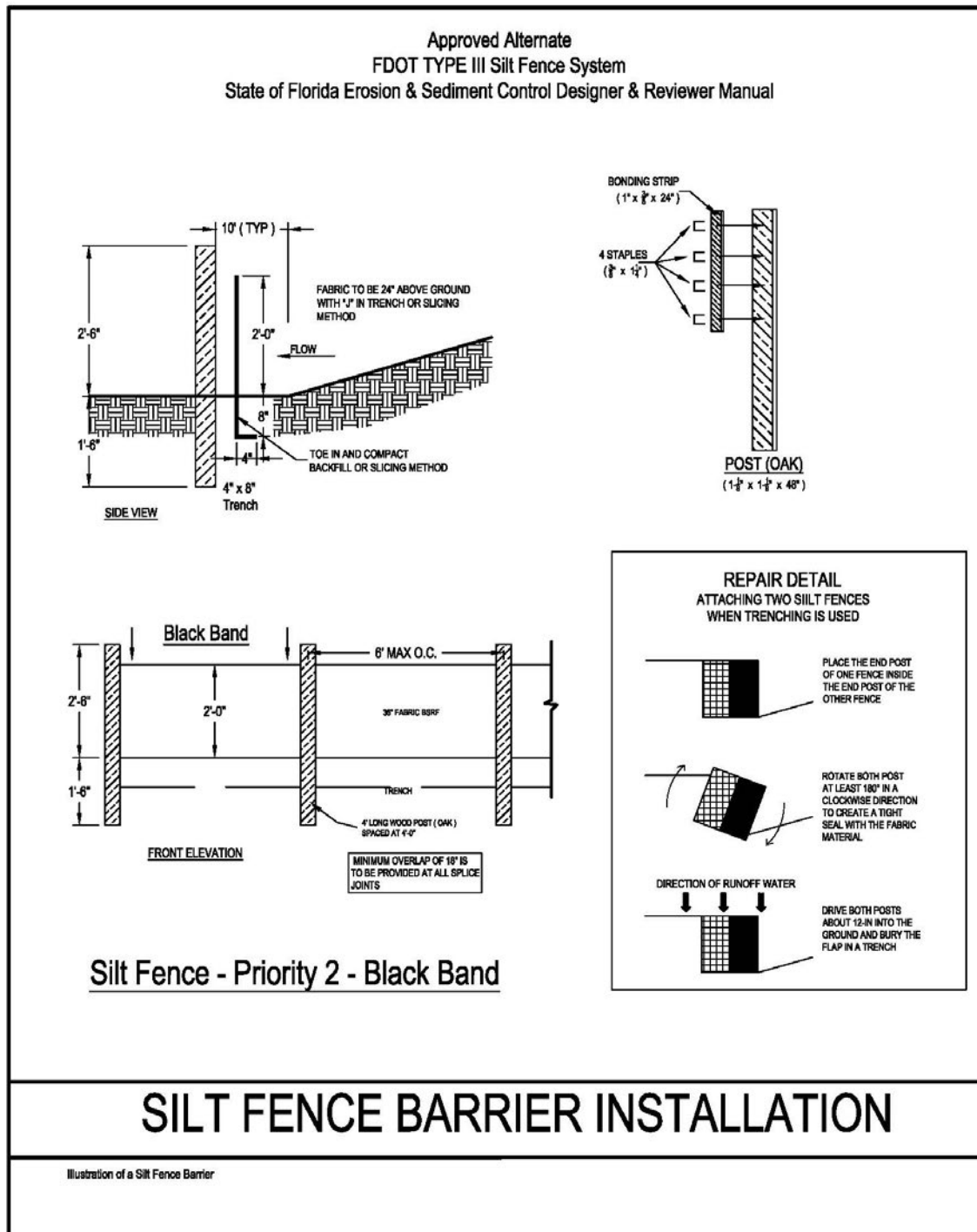

Figure V-3: Illustration of Silt Fence Priority 2 – Black Band

## Belted Silt Retention Fence – Type IV Priority 1

### **WHAT IS ITS PURPOSE?**

The BSRF shall be used as a vertical interceptor of sediment transported by overland *sheet flow* on construction sites. The Belted Silt Retention Fence (BSRF) has been designed and tested as a silt fence *system* with steel posts and wire supports. The BSRF is a 36-inch wide, spun-bond polyester fabric with an internal scrim. The system encompasses wood stakes and a specific method of attachment (see Installation Specifications in Notes below).

### **WHERE AND HOW IS IT COMMONLY USED?**

- At the toe of cut and fills slopes
- To protect water bodies.
- As a small sediment containment system
- To provide filtering capabilities in slurry conditions

### **WHEN SHOULD IT BE INSTALLED?**

- Before construction activities begin.
- It is designed for control of sheet flow.

### **WHEN SHOULD IT NOT BE INSTALLED?**

- Shall not be installed across streams, ditches, waterways, or anywhere there is concentrated flow.
- Shall not be placed around storm water inlets, which receive concentrate flow.

### **WHAT NEEDS TO BE INSPECTED?**

- Are stakes on the downstream side?
- Does water flow under the fabric?
- Has water flattened the structure?
- Is the fabric torn?
- Is the fabric secured correctly in the ground?
- Is the fabric attached to the posts?
- Will water flow around the fence?
- Has wind destroyed the fence?

### **WHAT MAINTENANCE ACTIVITIES CAN BE EXPECTED?**

- Regular inspection at the end of each workday and after each rainfall event.
- Remove the fence and accumulated sediment and stabilize the exposed area at completion of the project.
- Accumulated sediment should be removed when it reaches half the height of the fence to prevent failures.



### ***NOTES***

- As evidenced by a recent study, the BSRF meets the 75% filtration efficiency requirements of the Federal Highway Administration.
- Installation Specifications: The method of installation for the BSRF is an integral part of the system and is unlike any other installation practices. The specifically designed process includes wood (oak) stakes and wood bonding strips at four (4') foot intervals. Stakes that 4 feet high are driven to a depth, which allows 24" of fabric to be above ground. The fabric is then stretched along the inside perimeter of the stakes, pulled tightly and held in place with bonding strips. The bonding strips (typically 1" x 3/8" x 24") are attached to the stake with 1" x 1 1/4" staples. Four staples are used to secure the fabric in place against the 1 1/4" x 1 3/4" wood posts. This installation bonds the fabric and support system (scrim) to the vertical support post. The remaining fabric is now tucked into the trench forming a "J" and when filled with dirt creates a "ground bite". With its firm attachment to each post, the load is now spread to the total linear strength of all the posts within the system.
- *Any variance from the material specifications installation requirements may alter the performance of this product.* The product is available pre-staked to these specifications.

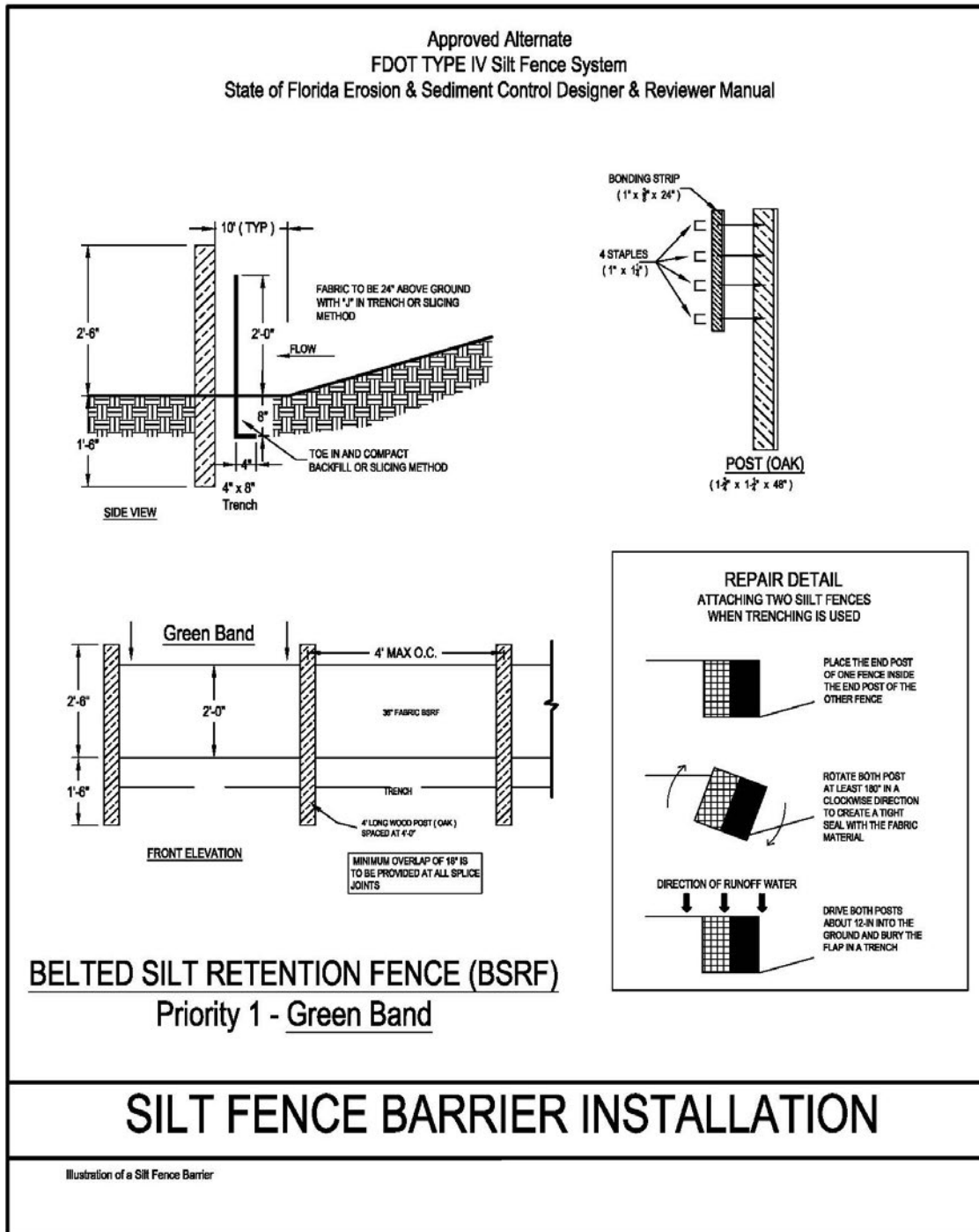

**Figure V-4: Illustration of Belted Silt Retention Fence – Type IV Priority 1**

### Fiber Log Barriers for Individual Lots

#### **WHAT IS ITS PURPOSE?**

Temporary sediment containment structures while construction activities occur.

#### **WHERE AND HOW IS IT COMMONLY USED?**

- As a temporary barrier to contain sediment on vertical construction lots.
- As a barrier in front of an area drain.
- As diversion structures.

#### **WHEN SHOULD IT BE INSTALLED?**

- Before construction activities begin.
- While construction activities are occurring.

#### **WHEN SHOULD IT NOT BE INSTALLED?**

- Where concentrated flows are expected such as in drainage ditches, around inlets, and above/below where culverts discharge.
- After construction activities are completed.

#### **WHAT NEEDS TO BE INSPECTED?**

- Is the material staked properly?
- Does water flow under the fiber log?
- Has traffic "flattened" the structure?
- Is the fiber log placed within a depression?
- Is the fiber log "pinned" on the upstream side?
- Will water flow around the fiber log?

#### **WHAT MAINTENANCE ACTIVITIES CAN BE EXPECTED?**

- Repair and replacement of the wattle.
- Removal of fiber log materials.
- Removal of sediment.

#### ***NOTES***

- Fiber logs are not to be used where concentrated flows of water are anticipated (e.g. in drainage ditches, around inlets, or above/below where culverts discharge) unless properly installed.
- Fiber logs can create a very small Type-2 sediment containment system to allow for deposition of suspended particles on vertical/big box construction sites.
- Fiber logs do not filter small (e.g. clay) suspended particles in runoff waters.

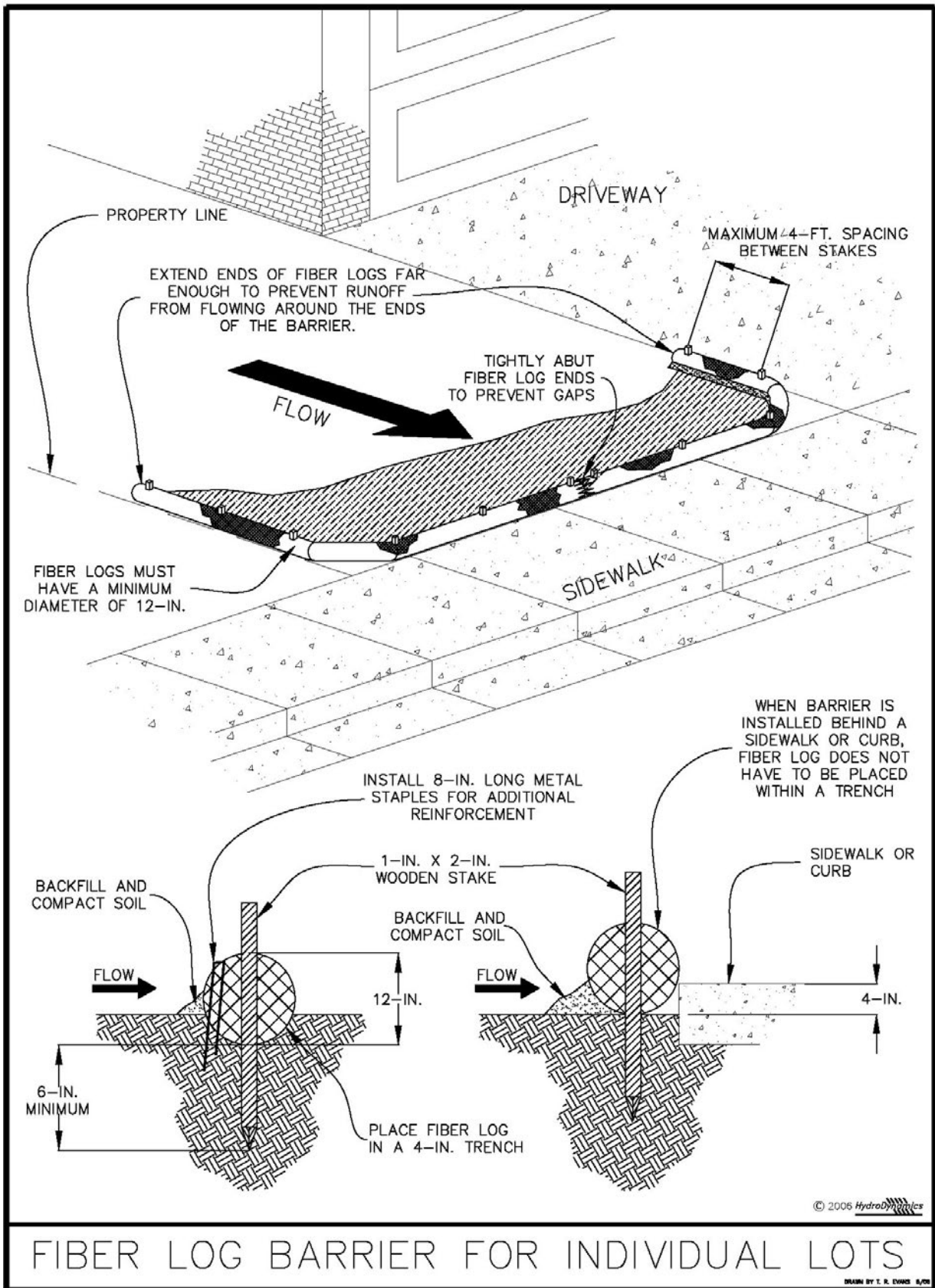

**Figure V-5. Illustration of Fiber Log Barriers for Individual Lots**

Permission is given by HydroDynamics Incorporated to copy and reproduce this detail

## Compost Filter Socks for Sediment Control

### **WHAT IS ITS PURPOSE?**

Temporary sediment containment structures while construction activities occur.

### **WHERE AND HOW IS IT COMMONLY USED?**

- As a temporary barrier to contain sediment on vertical construction lots.
- As a barrier in front of an area drain.
- As diversion structures.
- As a check dam.

### **WHEN SHOULD IT BE INSTALLED?**

- Before construction activities begin.
- While construction activities are occurring.

### **WHEN SHOULD IT NOT BE INSTALLED?**

- In streams or ephemeral waterways.
- On extremely rocky, bumpy, or unprepared ground surfaces.

### **WHAT NEEDS TO BE INSPECTED?**

- Is the material staked properly?
- Does the water flow under the compost filter sock?
- Has traffic “flattened” the structure?
- Will water flow around the compost filter sock?
- Is the correct compost media used inside the sock (Particle sizes = 99% < 3 in, 50% > 3/8 in)?
- Is the mesh netting material made of photodegradable (polypropylene, HDPE) or biodegradable (cotton) knitted fabric with 1/8 to 3/8 in openings?

### **WHAT MAINTENANCE ACTIVITIES CAN BE EXPECTED?**

- Repair and replacement of sock (if needed).
- Removal of netting (compost may be incorporated into landscape).
- Removal of sediment.

### ***NOTES***

- Compost filter socks have been shown to remove suspended solids, heavy metals, petroleum hydrocarbons, harmful bacteria, and nutrients from stormwater runoff.
- Compost filter media may be left on site and incorporated into the landscape once stabilization is complete. Netting should be removed.
- Compost filter socks are available in a variety of diameters, including 8 in, 12 in, 18 in, and 24 in.
- Compost filter socks can be used as a Type-2 sediment containment system to allow for deposition of suspended particles on vertical/big box construction sites.

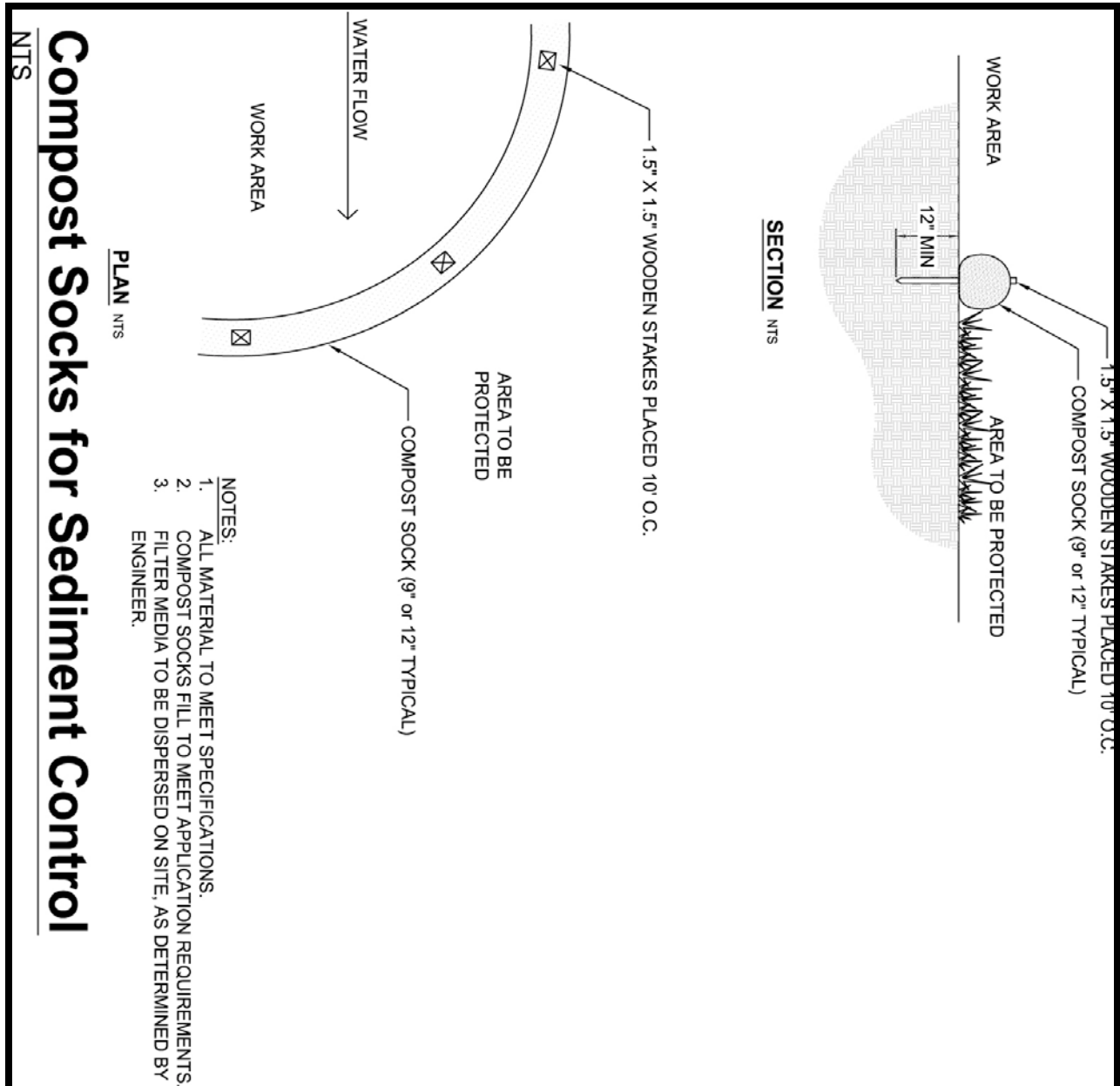

Figure V-6. Illustration of Compost Filter Sock for Sediment Control

Continuous Berm Barrier

**WHAT IS ITS PURPOSE?**

Temporary sediment containment structures while construction activities occur.

**WHERE AND HOW IS IT COMMONLY USED?**

- At the toe of cut and fill slopes.
- As small sediment containment structures.
- As diversion structures.
- Protecting water bodies.

**WHEN SHOULD IT BE INSTALLED?**

- Before construction activities begin.
- While construction activities are occurring.

**WHEN SHOULD IT NOT BE INSTALLED?**

- After construction activities are completed.

**WHAT NEEDS TO BE INSPECTED?**

- Is the fabric material torn?
- Has the berm been destroyed?
- Are the top fasteners in place?
- Does water drain through the rock?

**WHAT MAINTENANCE ACTIVITIES CAN BE EXPECTED?**

- Repair destroyed sections.
- Removal of sediment.
- Removal of the berm.

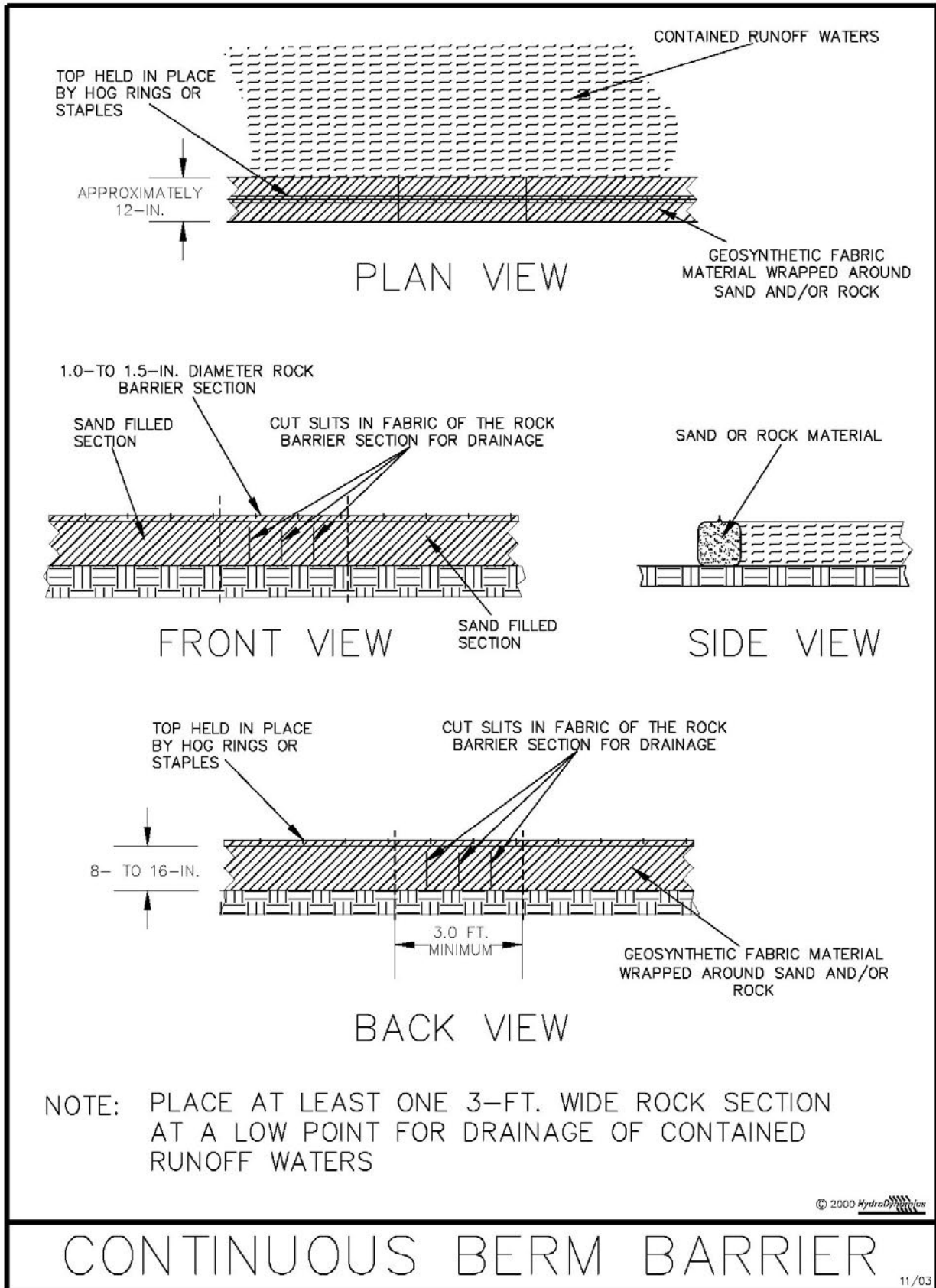

**Figure V-7: Illustration of a Continuous Berm Barrier**

Permission is given by HydroDynamics Incorporated to copy and reproduce this detail



## Geosynthetic Barrier

### **WHAT IS ITS PURPOSE?**

Temporary sediment containment structures while construction activities occur.

### **WHERE AND HOW IS IT COMMONLY USED?**

- At the toe of cut and fill slopes.
- As small check structures.

### **WHEN SHOULD IT BE INSTALLED?**

- Before construction activities begin.
- While construction activities are occurring.

### **WHEN SHOULD IT NOT BE INSTALLED?**

- After construction activities are completed.

### **WHAT NEEDS TO BE INSPECTED?**

- Is the structure installed per manufacturer specifications?
- Is it properly stapled?
- Will water flow over the structure?
- Will water flow around the structure?
- Does water flow between the structures?
- Does water flow under the structure?

### **WHAT MAINTENANCE ACTIVITIES CAN BE EXPECTED?**

- Repair and replacement of structures.
- Removal of sediment.
- Repair of eroded ground.
- Removal of structures.

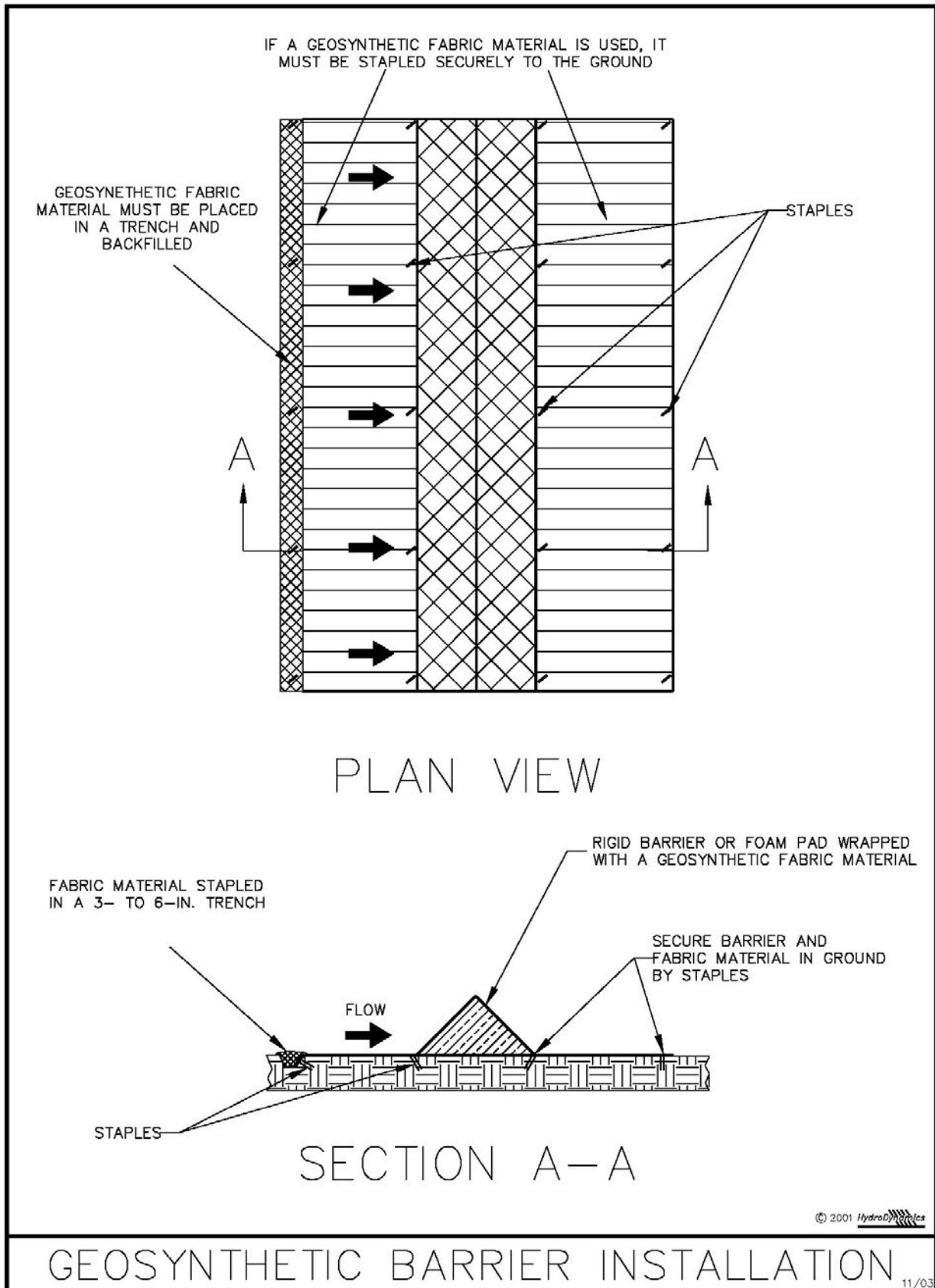

Figure V-8: Illustration of a Geosynthetic Barrier

Permission is given by HydroDynamics Incorporated to copy and reproduce this detail

## Floating Turbidity Barrier

### **WHAT IS ITS PURPOSE?**

A temporary sediment containment structure suspended vertically in water bodies for the purpose of preventing sediment-laden water from escaping the immediate work area and entering the main body of water during construction activities

### **WHERE AND HOW IS IT COMMONLY USED?**

- In bays, lakes, rivers, and streams.
- To protect wetlands.
- As a sediment containment system

### **WHEN SHOULD IT BE INSTALLED?**

- Before construction activities begin.
- While construction activities are occurring.

### **WHEN SHOULD IT NOT BE INSTALLED?**

- Where water currents perpendicular to the barrier exceed 3 knots, or wind/weather conditions are too great to be effective.
- After construction activities are completed.

### **WHAT NEEDS TO BE INSPECTED?**

- Is the curtain anchored properly for the site conditions?
- Does the curtain contain turbidity?
- Does the barrier float with at least 4-inch freeboard?
- Does the curtain move excessively?

### **WHAT MAINTENANCE ACTIVITIES CAN BE EXPECTED?**

- Regular inspection of installed barrier and anchor systems.
- Removal of curtain material at completion of job.
- Repair and replacement of damaged barrier material.

### ***NOTES***

- Do not install turbidity barriers where the flow of water is greater than 3 knots perpendicular to the barrier.
- When winds/tides change regularly, anchor systems must be placed on opposite sides of the barrier to prevent it from overriding an anchor.
- When used in a live stream, turbidity barriers must be installed parallel, not perpendicular, to the water flow.

- Barrier should never be anchored from the bottom hem.
- Barrier should not be installed so close to construction activity as to risk damaging the barrier or otherwise reducing its efficiency.
- A minimum distance of 12 inch must be maintained between the barrier skirt hem and the bottom at the mean low water level.
- When barrier is installed in a navigable waterway, lighted buoy(s) must conform to regulatory standards.
- Installation should follow manufacturer's guidelines.

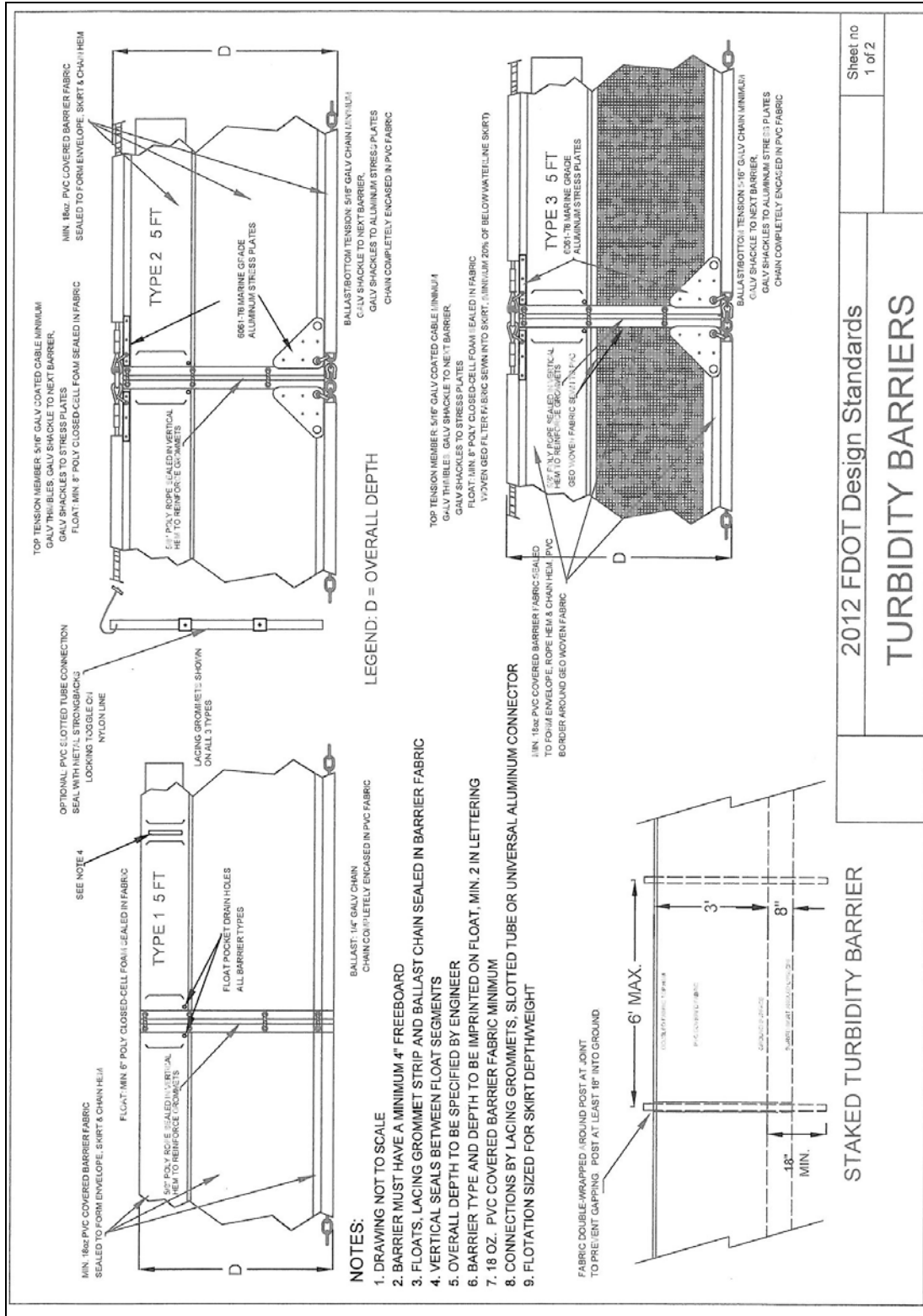

Figure V-9: Illustration of Installing a Floating Turbidity Barrier

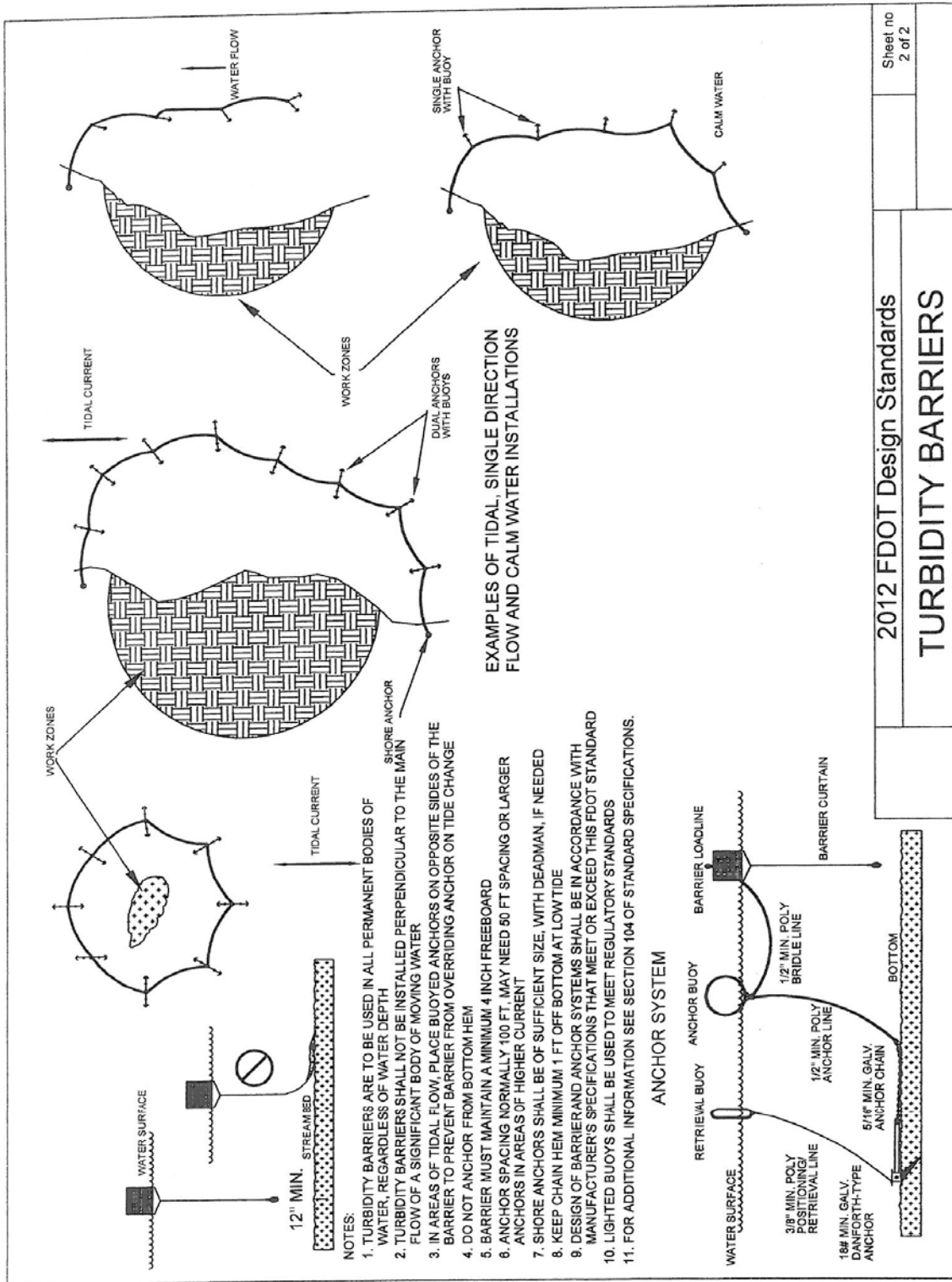

Figure V-10: Illustration of Installing a Floating Turbidity Barrier

## Staked Turbidity Barrier (Belted Silt Retention Fence)

### **WHAT IS ITS PURPOSE?**

The BSRF shall be used as a vertical interceptor of sediment transported by overland *sheet flow* on construction sites. The Belted Silt Retention Fence (BSRF) has been designed and tested as a silt fence *system*. The BSRF is a 36-inch wide, spun-bond polyester fabric with an internal scrim. The system encompasses wood stakes and a specific method of attachment (see Installation Specifications in Notes below).

### **WHERE AND HOW IS IT COMMONLY USED?**

- At the toe of cut and fills slopes
- To protect water bodies.
- As a small sediment containment system
- To provide filtering capabilities in slurry conditions

### **WHEN SHOULD IT BE INSTALLED?**

- Before construction activities begin.
- It is designed for control of sheet flow.

### **WHEN SHOULD IT NOT BE INSTALLED?**

- Shall not be installed across streams, ditches, waterways, or anywhere there is concentrated flow.
- Shall not be placed around storm water inlets, which receive concentrate flow.

### **WHAT NEEDS TO BE INSPECTED?**

- Are stakes on the downstream side?
- Does water flow under the fabric?
- Has water flattened the structure?
- Is the fabric torn?
- Is the fabric secured correctly in the ground?
- Is the fabric attached to the posts?
- Will water flow around the fence?
- Has wind destroyed the fence?

### **WHAT MAINTENANCE ACTIVITIES CAN BE EXPECTED?**

- Regular inspection at the end of each workday and after each rainfall event.
- Remove the fence and accumulated sediment and stabilize the exposed area at completion of the project.
- Accumulated sediment should be removed when it reaches half the height of the fence to prevent failures.

### ***NOTES***

- As evidenced by a recent study, the BSRF meets the 75% filtration efficiency requirements of the Federal Highway Administration.
- Installation Specifications: The method of installation for the BSRF is an integral part of the system and is unlike any other installation practices. The specifically designed process includes wood (oak) stakes and wood bonding strips at four (4') foot intervals. Stakes that 4 feet high are driven to a depth, which allows 24" of fabric to be above ground. The fabric is then stretched along the inside perimeter of the stakes, pulled tightly and held in place with bonding strips. The bonding strips (typically 1" x 3/8" x 24") are attached to the stake with 1" x 1 1/4" staples. Four staples are used to secure the fabric in place against the 1 1/4" x 1 3/4" wood posts. This installation bonds the fabric and support system (scrim) to the vertical support post. The remaining fabric is now tucked into the trench forming a "J" and when filled with dirt creates a "ground bite". With its firm attachment to each post, the load is now spread to the total linear strength of all the posts within the system.
- *Any variance from the material specifications installation requirements may alter the performance of this product.* The product is available pre-staked to these specifications.



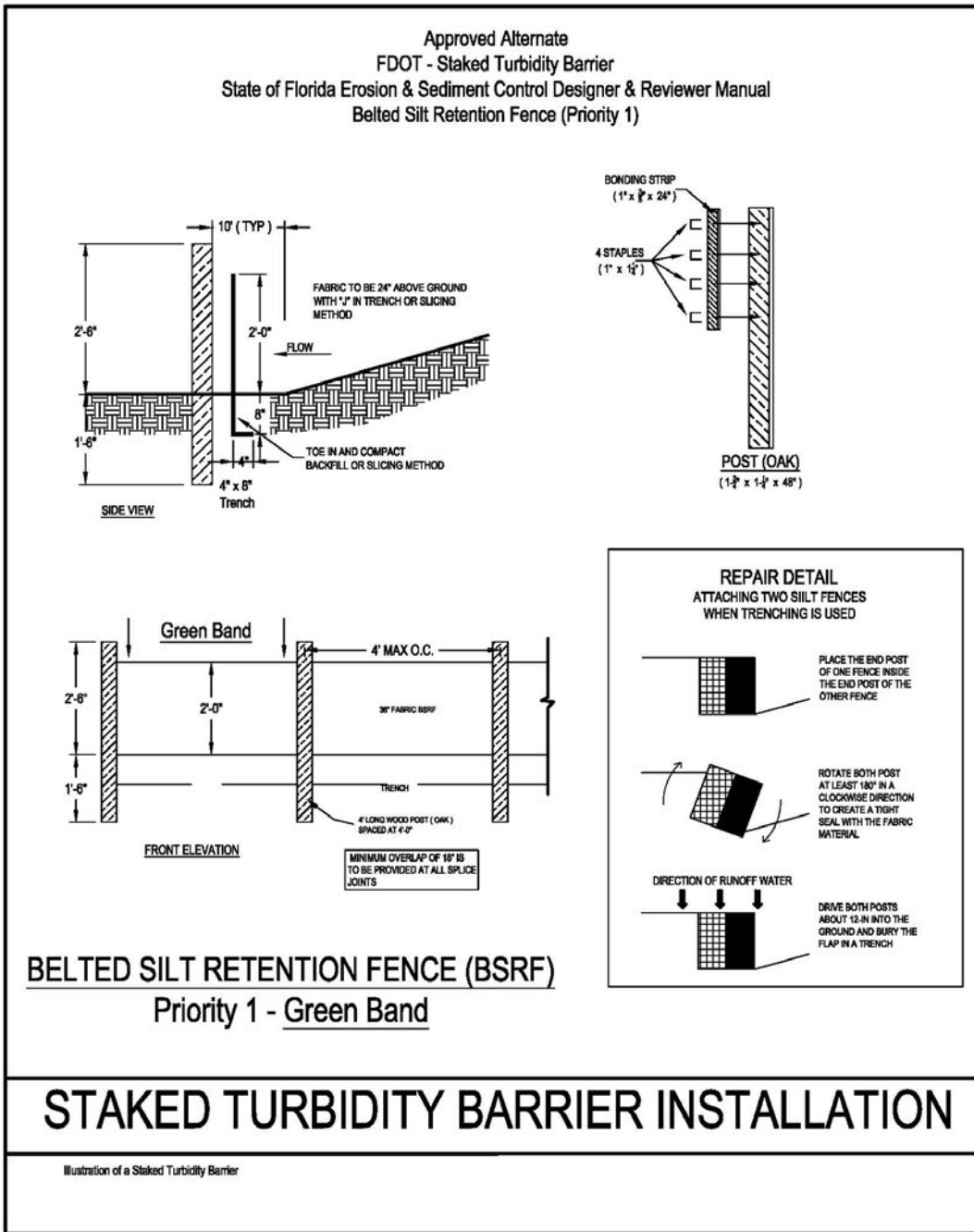

Figure V-11: Illustration of Staked Turbidity Barrier (Belted Silt Retention Fence)

### Water Filled Barrier

#### **WHAT IS ITS PURPOSE?**

Temporary containment structures that force water away from a construction site as activities occur to create a “dry” working space.

#### **WHERE AND HOW IS IT COMMONLY USED?**

- At water embankments.
- As a small cofferdam.
- As small containment systems.
- In streambeds and ponds.
- To create a dry working space.
- To protect water bodies.

#### **WHEN SHOULD IT BE INSTALLED?**

- Before construction activities begin.
- While construction activities are occurring.

#### **WHEN SHOULD IT NOT BE INSTALLED?**

- Streams where high flows could destroy the barrier.
- After construction activities are completed.

#### **WHAT NEEDS TO BE INSPECTED?**

- Is the tube sufficiently filled with water?
- Where and how are captured sediment-laden waters discharged?
- Does the barrier hold water?
- Is water entering the working area?
- Is the construction area stabilized before removing the barrier?
- Have flows destroyed the barrier?

#### **WHAT MAINTENANCE ACTIVITIES CAN BE EXPECTED?**

- Repair of the barrier.
- Discharge of waters.
- Removal of accumulated sediment.
- Removal of barrier.

#### ***NOTES***

- A water-filled barrier provides a temporary work area where extensive amounts of water can be anticipated.
- Sediment-laden waters are to be pumped away from the barrier using a sediment containment filter bag.

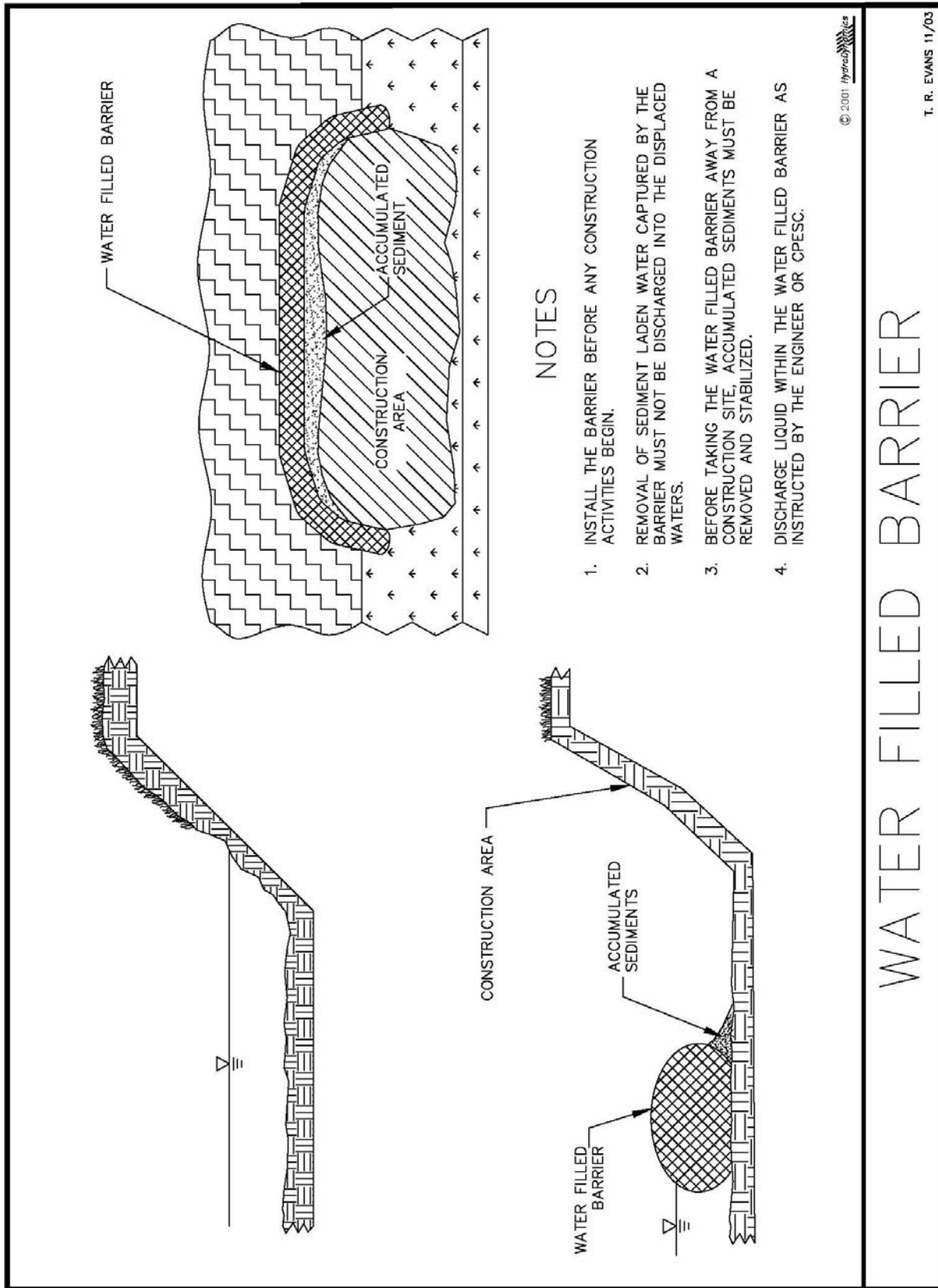

**Figure V-12: Illustration of a Water Filled Barrier**

Permission is given by HydroDynamics Incorporated to copy and reproduce this detail

Rock Barrier for an Area Drain (a.k.a. Drop, Catch Basin, or Ditch Bottom) Inlet

**WHAT IS ITS PURPOSE?**

Temporary barriers to cause waters to pond and drain so that sediment can settle out of runoff waters while construction activities occur.

**WHERE AND HOW IS IT COMMONLY USED?**

- Around median inlets.
- Around inlets to which runoff water flows.

**WHEN SHOULD IT BE INSTALLED?**

- While construction activities are occurring.
- Only where sump conditions exist.

**WHEN SHOULD IT NOT BE INSTALLED?**

- After construction activities are completed.
- Where sump conditions do not exist.

**WHAT NEEDS TO BE INSPECTED?**

- Is at least 1.0-in. diameter rock used?
- Has wire mesh been used?
- Can water flow over the rock?
- Should the rock be replaced?
- Does water flow through the rock?
- Does the rock need "raking?"
- Will water be diverted downstream?

**WHAT MAINTENANCE ACTIVITIES CAN BE EXPECTED?**

- Repair and replacement of rock.
- Removal of sediment.
- Removal of rock.

***NOTES***

- Rock barriers placed around inlets will allow water to drain.
- Use only wire mesh instead of materials such as chicken wire.
- Rock barriers are to be installed in "sump" conditions only. Rock barriers in front of inlets on a grade will divert runoff to downstream locations.
- Rock barriers in front of inlets provide little filtering and capture little sediment from runoff waters for large frequency storm events.

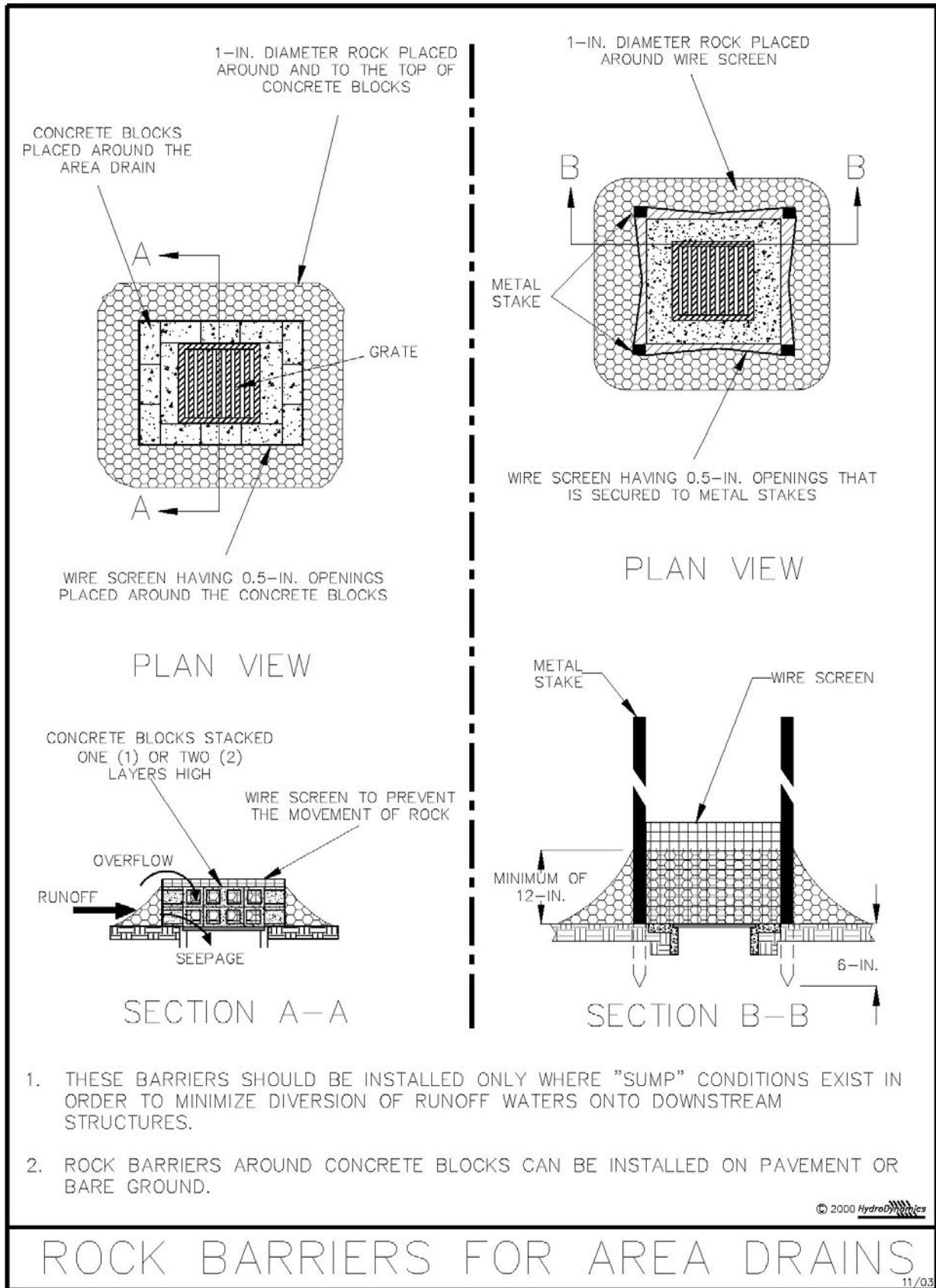

**Figure V-13: Illustration of Rock Barriers around Area Drains**

Permission is given by HydroDynamics Incorporated to copy and reproduce this detail

Frame & Filter Barrier for Area Drain (a.k.a. Drop, Catch Basin, or Ditch Bottom) Inlets

**WHAT IS ITS PURPOSE?**

Temporary barriers to cause waters to pond and drain so that sediment can settle out of runoff waters while construction activities occur.

**WHERE AND HOW IS IT COMMONLY USED?**

- Around median inlets.
- Around inlets to which runoff flows.

**WHEN SHOULD IT BE INSTALLED?**

- While construction activities are occurring.
- Only where “sump” conditions exist.

**WHEN SHOULD IT NOT BE INSTALLED?**

- After construction activities are completed.
- Where “sump” conditions do not exist.
- In locations that could lead to potential flooding such as encroachment on travel lanes of a roadway.

**WHAT NEEDS TO BE INSPECTED?**

- Has the unit been placed over the grate?
- Is there sufficient soil or gravel to seal the cover?
- Does accumulated sediment cover 2/3 of the filter barrier height?
- Does it appear that runoff is flowing under the fabric material?
- Do “sump” conditions exist?
- Is the fabric material torn?
- Is the frame still supporting the fabric material?
- Does runoff drain through the fabric material?

**WHAT MAINTENANCE ACTIVITIES CAN BE EXPECTED?**

- Repair and replacement of gravel in the pocket.
- Replacement of fabric material.
- Removal of sediment around the unit.

***NOTES***

- These barriers are to be installed in "sump" conditions only. If placed in front of inlets on a grade, runoff will be diverted to downstream locations and could cause flooding.
- It is critical that a good seal exist between the ground and fabric material using adequate amounts of soil or gravel.
- Multiple types of filter media are available for this system. The correct type of filter fabric should be chosen that considers both safety and environmental concerns.

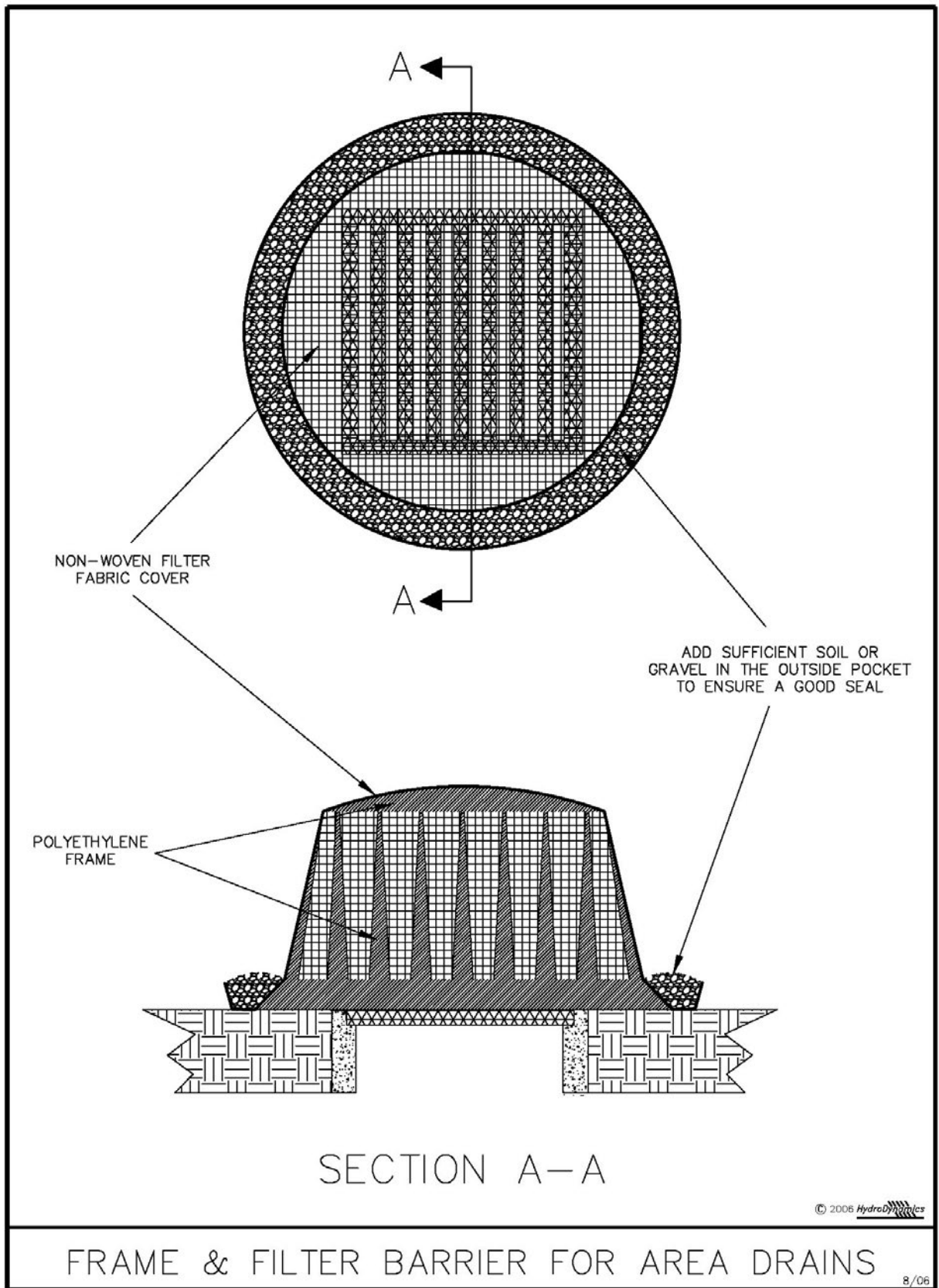

**Figure V-14: Illustration of a Frame & Filter Barrier for Area Drains**

Permission is given by HydroDynamics Incorporated to copy and reproduce this detail

### Curb Inlet “Sump” Barrier

#### **WHAT IS ITS PURPOSE?**

Temporary barriers to cause waters to pond and drain so that sediment can settle out of runoff waters while construction activities occur.

#### **WHERE AND HOW ARE THEY COMMONLY USED?**

- In front of curb inlets.
- Reduce sediment entering a storm sewer system.

#### **WHEN SHOULD IT BE INSTALLED?**

- While construction activities are occurring.
- Only where “sump” conditions exist.

#### **WHEN SHOULD IT NOT BE INSTALLED?**

- After construction activities are completed.
- Where “sump” conditions do not exist.

#### **WHAT NEEDS TO BE INSPECTED?**

- Is at least 1.0-in. diameter rock used?
- Has wire mesh been used?
- Can water flow over the rock?
- Should the rock be replaced?
- Does water flow through the rock?
- Does the rock need "raking?"
- Will water be diverted downstream?
- Have vehicles destroyed the structure?

#### **WHAT MAINTENANCE ACTIVITIES CAN BE EXPECTED?**

- Repair and replacement of rock.
- Removal of sediment.
- Removal of rock.

#### ***NOTES***

- Rock barriers are to be installed in “sump” conditions only.
- Wire mesh should be used instead of more open materials such as chicken wire.
- Rock barriers in front of inlets provide little filtering effect and capture little sediment from runoff waters.
- Warning signs should be used to alert drivers of the structures.
- Rock barriers in front of inlets may cause destruction of the pavement due to excess seepage of water or freezing conditions.
- If placed on a grade, the structure will divert runoff downstream and may cause flooding.



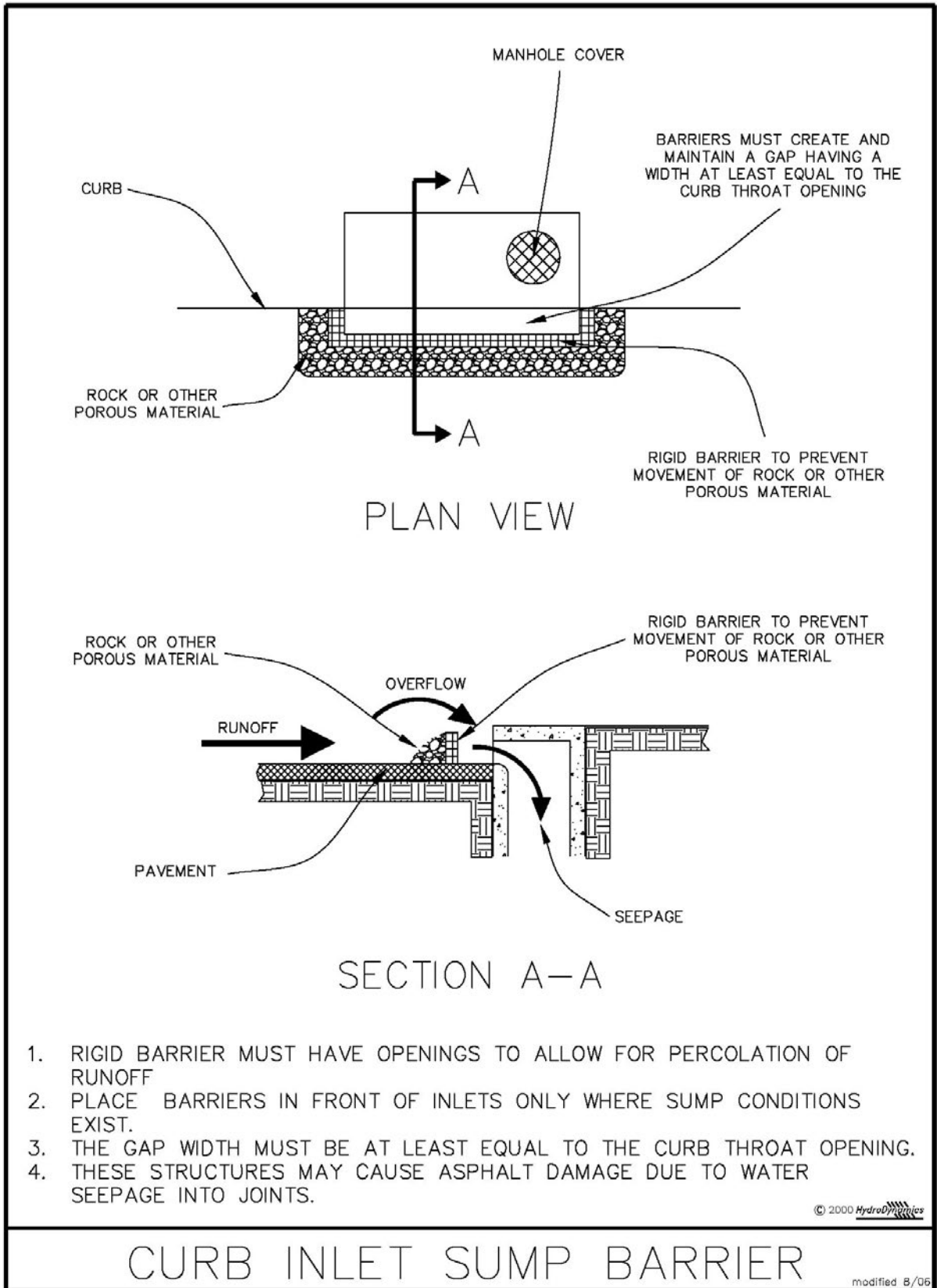

**Figure V-15: Illustration of a Curb Inlet “Sump” Barrier**

Permission is given by HydroDynamics Incorporated to copy and reproduce this detail

### Curb Inlet Diversion Berm

#### **WHAT IS ITS PURPOSE?**

Temporary barriers to force runoff into a curb inlet when a downstream sediment containment system exists.

#### **WHERE AND HOW IS IT COMMONLY USED?**

- Immediately below an inlet opening.
- Used to force runoff into an inlet that drains into a sediment containment system.

#### **WHEN SHOULD IT BE INSTALLED?**

- While construction activities are occurring.
- At any curb inlet.

#### **WHEN SHOULD IT NOT BE INSTALLED?**

- After construction activities are completed.
- Where diverted runoff will not enter a sediment containment system.

#### **WHAT NEEDS TO BE INSPECTED?**

- Have the diversion bags been destroyed?
- Is water being diverted into the inlet?
- Should signage be installed?
- Should the bags be replaced?

#### **WHAT MAINTENANCE ACTIVITIES CAN BE EXPECTED?**

- Repair and replacement of bags.
- Removal of the diversion bags as full build out conditions develop.

#### ***NOTES***

- Warning signs should be used to alert drivers of the structures.

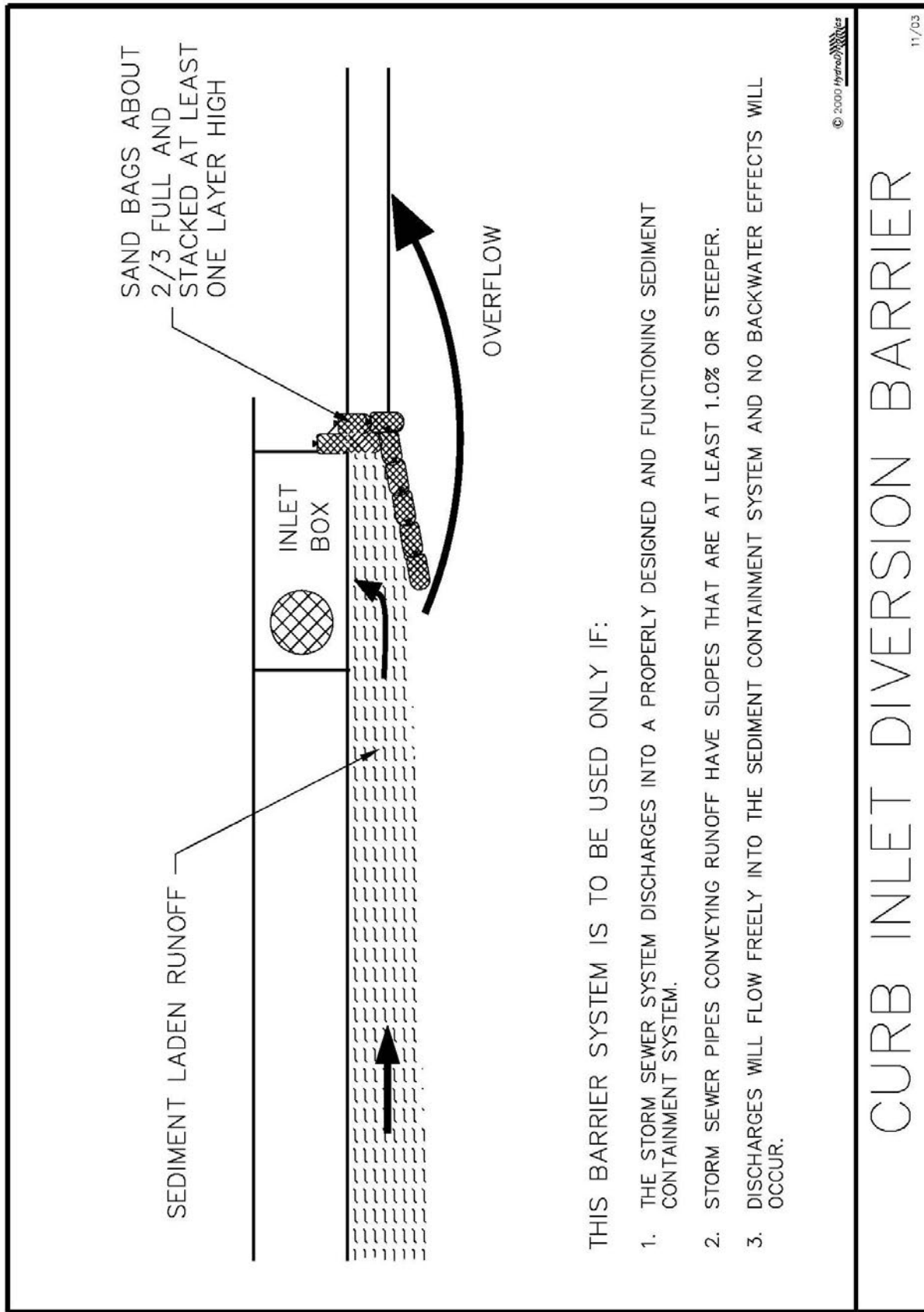

**Figure V-16: Illustration of a Curb Inlet Diversion Berm**

Permission is given by HydroDynamics Incorporated to copy and reproduce this detail

### Curb and Gutter Sediment Containment System Detail

#### **WHAT IS ITS PURPOSE?**

Temporary barriers to cause waters to pond and drain so that sediment can settle out of runoff waters while construction activities occur.

#### **WHERE AND HOW IS IT COMMONLY USED?**

- In gutters and upstream of inlets.
- Reduce sediment entering a storm sewer system.

#### **WHEN SHOULD IT BE INSTALLED?**

- While construction activities are occurring.
- Where street grades exist.

#### **WHEN SHOULD IT NOT BE INSTALLED?**

- After construction activities are completed.
- Where “sump” conditions exist.

#### **WHAT NEEDS TO BE INSPECTED?**

- Are the bags about 2/3 full?
- Is collected sediment being removed?
- Is the spacing correct (see table)?
- Have vehicles destroyed the bags?

#### **WHAT MAINTENANCE ACTIVITIES CAN BE EXPECTED?**

- Repair and replacement of bags.
- Removal of sediment.
- Removal of bags.

#### ***NOTES***

- Vehicles will destroy the bags.
- Warning signs should be used to alert drivers of the structures.
- Sediment must be removed after every runoff event.
- Water should not be allowed to remain behind the bags.

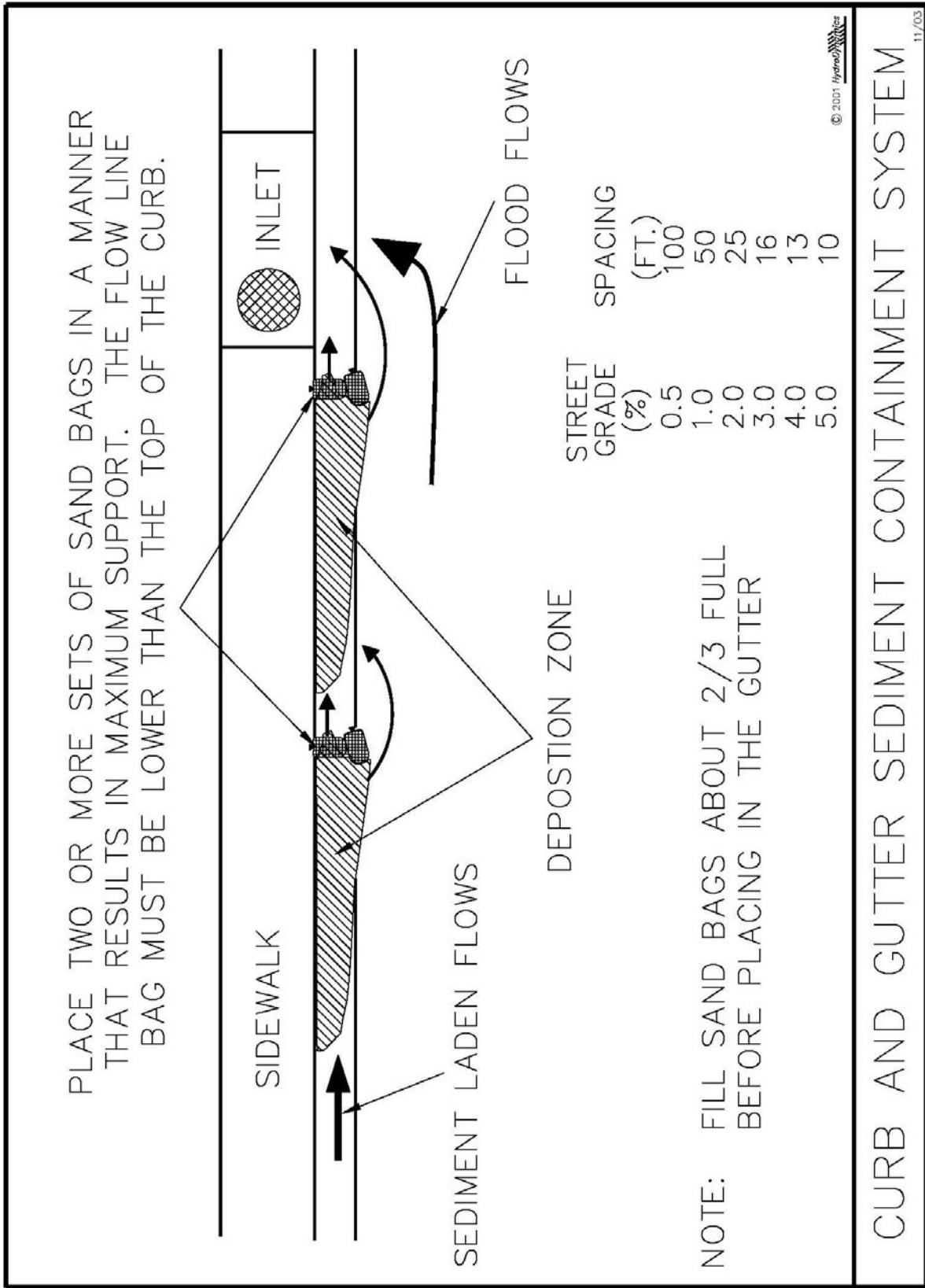

**Figure V-19: Illustration of a Curb and Gutter Sediment Containment System**

Permission is given by HydroDynamics Incorporated to copy and reproduce this detail

### Curb Inlet Insert

#### **WHAT IS ITS PURPOSE?**

Temporary SCS inserted into an inlet to capture larger diameter sediments found in runoff waters.

#### **WHERE AND HOW ARE THEY COMMONLY USED?**

- Within curb inlets.
- Within a catch basin.

#### **WHEN SHOULD IT BE INSTALLED?**

- While construction activities are occurring.
- Within inlets that are on a grade or in a sump.

#### **WHEN SHOULD IT NOT BE INSTALLED?**

- At a location to serve as the only sediment containment system.

#### **WHAT NEEDS TO BE INSPECTED?**

- Is the fabric material torn?
- Is the containment bag over ½ full?
- Will water flow into the material?
- Does the fabric appear around the grate?

#### **WHAT MAINTENANCE ACTIVITIES CAN BE EXPECTED?**

- Repair and replacement of material.
- Removal of sediment.

#### ***NOTES***

- Be sure to empty the units before winter conditions occur.
- Do not rely on these units to be the only sediment control devices on a construction site.

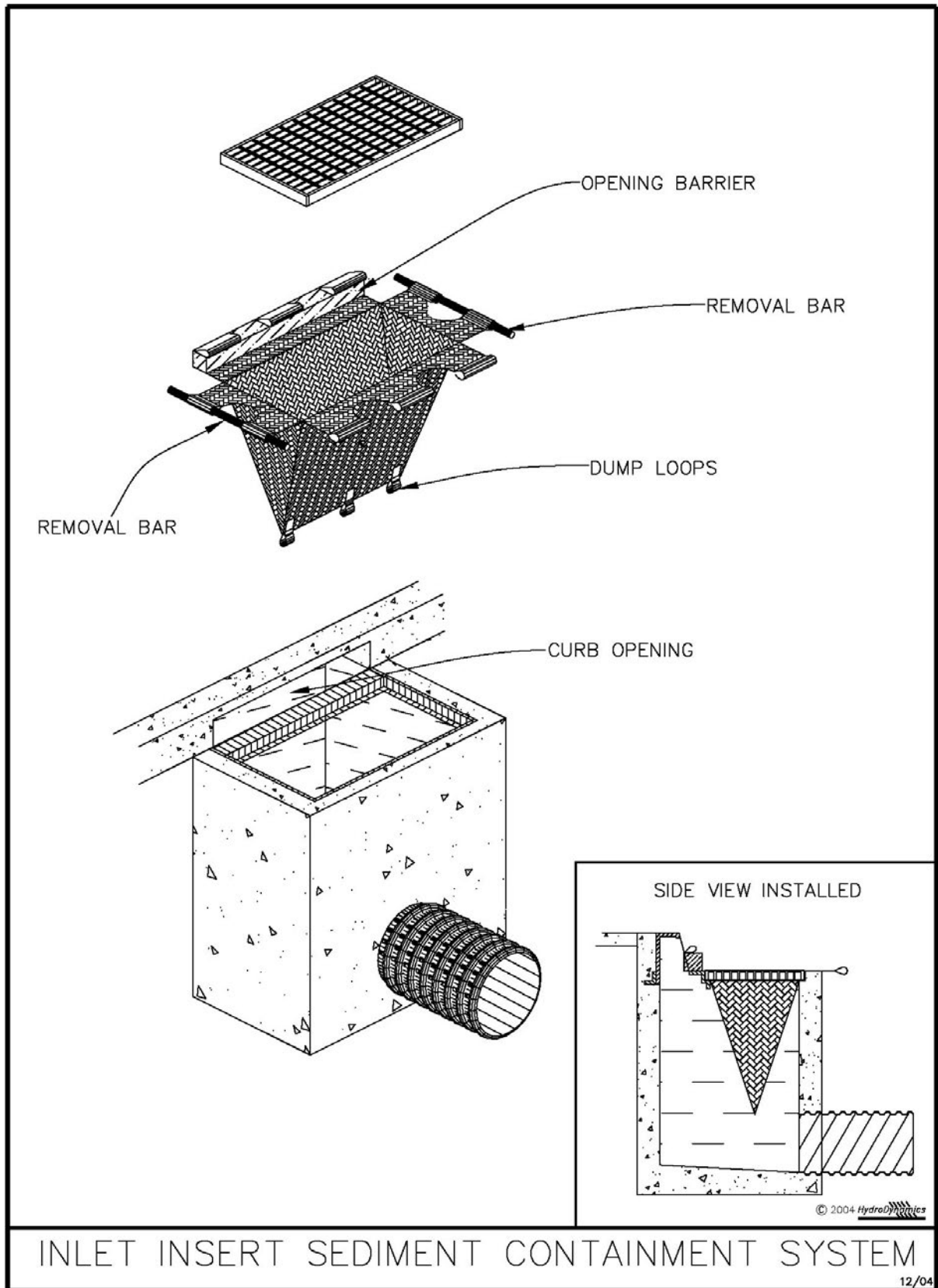

**Figure V-18: Illustration of an Inlet Insert Sediment Containment System**

Permission is given by HydroDynamics Incorporated to copy and reproduce this detail

### Soil Tracking Prevention Device

#### **WHAT IS ITS PURPOSE?**

Temporary structures to assist with removal of soil material captured on vehicle tires entering and leaving a construction site.

#### **WHERE AND HOW IS IT COMMONLY USED?**

- Major entrances into construction sites.

#### **WHEN SHOULD IT BE INSTALLED?**

- Before construction activities begin.
- During construction activities.

#### **WHEN SHOULD IT NOT BE INSTALLED?**

- After construction activities are completed.

#### **WHAT NEEDS TO BE INSPECTED?**

- Are the correct rock diameters used?
- Is there a depression for runoff?
- Is rock being carried out into a street?
- Does rock need to be replaced?

#### **WHAT MAINTENANCE ACTIVITIES CAN BE EXPECTED?**

- Replacement of rock.
- Removal of sediment on adjacent streets.



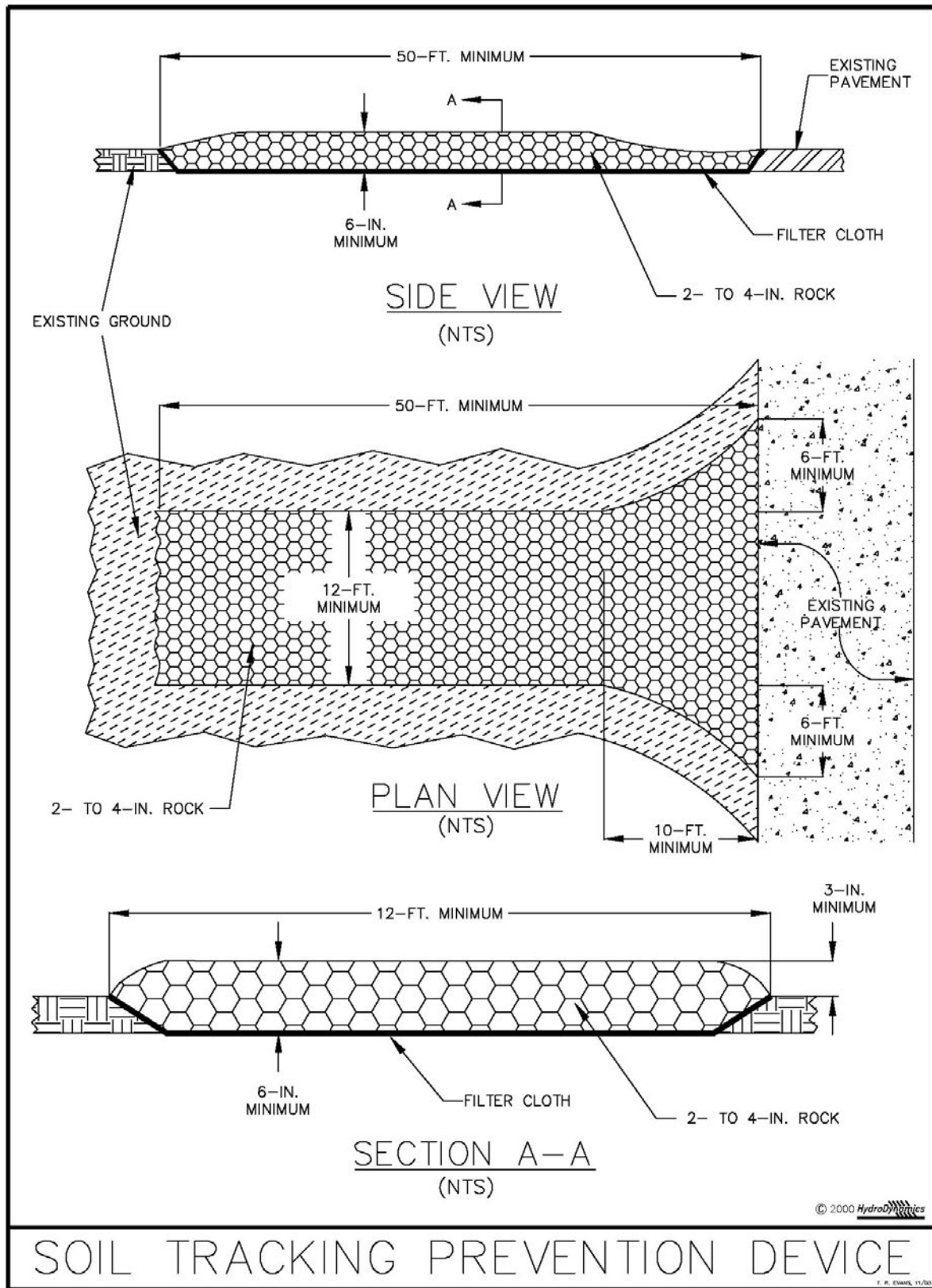

**Figure V-19: Illustration of a Soil Tracking Prevention Device**

Permission is given by HydroDynamics Incorporated to copy and reproduce this detail

### Cellular Confinement System

#### **WHAT IS ITS PURPOSE?**

To protect hillsides or drainage channels against erosion due to flowing water or to be used as a temporary stream crossing.

#### **WHERE AND HOW IS IT COMMONLY USED?**

- In areas where concentrated flows occur and where greater erosion protection is needed that exceeds what a Rolled Erosion Control Product (RECP) provides.
- Provides a temporary stream crossing system that is able to withstand heavy loads and traffic.

#### **WHEN SHOULD IT BE INSTALLED?**

- While construction activities are occurring.
- After construction activities are finished.

#### **WHEN SHOULD IT NOT BE INSTALLED?**

Over impervious surfaces.

#### **WHAT NEEDS TO BE INSPECTED?**

- Does the system display any damage?
- Is the system held in place by staples or pins?
- Have all the cells been filled with rock, soils or cement?
- Has the system been installed as required by the manufacturer?
- Is a geotextile blanket used?
- If the cells are filled with soil, has seeding and mulching been completed?

#### **WHAT MAINTENANCE ACTIVITIES CAN BE EXPECTED?**

- Repair and replacement of cell material.      ▪ Evaluation of material in cells.
- Slippage down a slope.

#### ***NOTES***

- Possibly can be used as a temporary soil tracking prevention device.



### ***Using BMPs When Building Box Culverts***

Sections III, IV, and V provide illustrations of many different BMPs that can be utilized before, during, and after construction activities occur. Figure V-16 illustrates four different scenarios that might be considered in using different BMPs during the construction of box culverts.

Scenario No. 1: If a Designer is confident that offsite runoff waters will not discharge through the construction activity area, the only BMPs that may be necessary are properly installed silt fence barriers, slope drains, and erosion control of the embankments. Also, this scenario assumes that access to the construction site is through an existing (or under construction) roadway. Some important items for Designers to consider include:

- Concentrated off-site flows cannot discharge through the construction site.
- Access to the construction site is through an existing road.
- Topsoil storage, staging, and access to the site must be completed in a manner that ensures runoff from these areas discharge into a temporary containment system created by the silt fence barrier.
- A slope drain is installed to ensure road runoff is conveyed down the fill slope and away from the active construction site.
- Erosion protection of disturbed slopes must occur as soon as possible.

Scenario No. 2: Consideration of this scenario can occur when periodic offsite flows will not inundate the construction site and/or access cannot occur from an existing roadway. Some important items for Designers to consider include:

- Only periodic and small concentrated off-site flows will discharge through the construction site.
- All temporary earthen berms must be stabilized against erosion while construction activities occur.
- Topsoil storage and staging must be completed in a manner that ensures runoff from these areas discharge into the temporary containment system created by the earthen berm and rock outlet structure.
- Frequent maintenance activities can be expected to remove accumulated sediments and runoff waters.
- A silt fence barrier is required along the downstream side of an access road.
- A slope drain may be required to ensure road runoff is conveyed down the fill slope and away from the active construction site.
- Erosion protection of disturbed slopes must occur as soon as possible.

Scenario No. 3 and No. 4: These scenarios are perturbations of the first two scenarios when offsite flows need to be diverted and/or installation of box culverts occur through an existing or developing roadway. Along with items identified above, Designers also need to consider the following:

- If pumping is to occur, sufficient containment volume must exist for the anticipated inflow of offsite waters and removal by pumping.

- Erosion protection of any diversion channels and embankments must occur while construction activities happen.

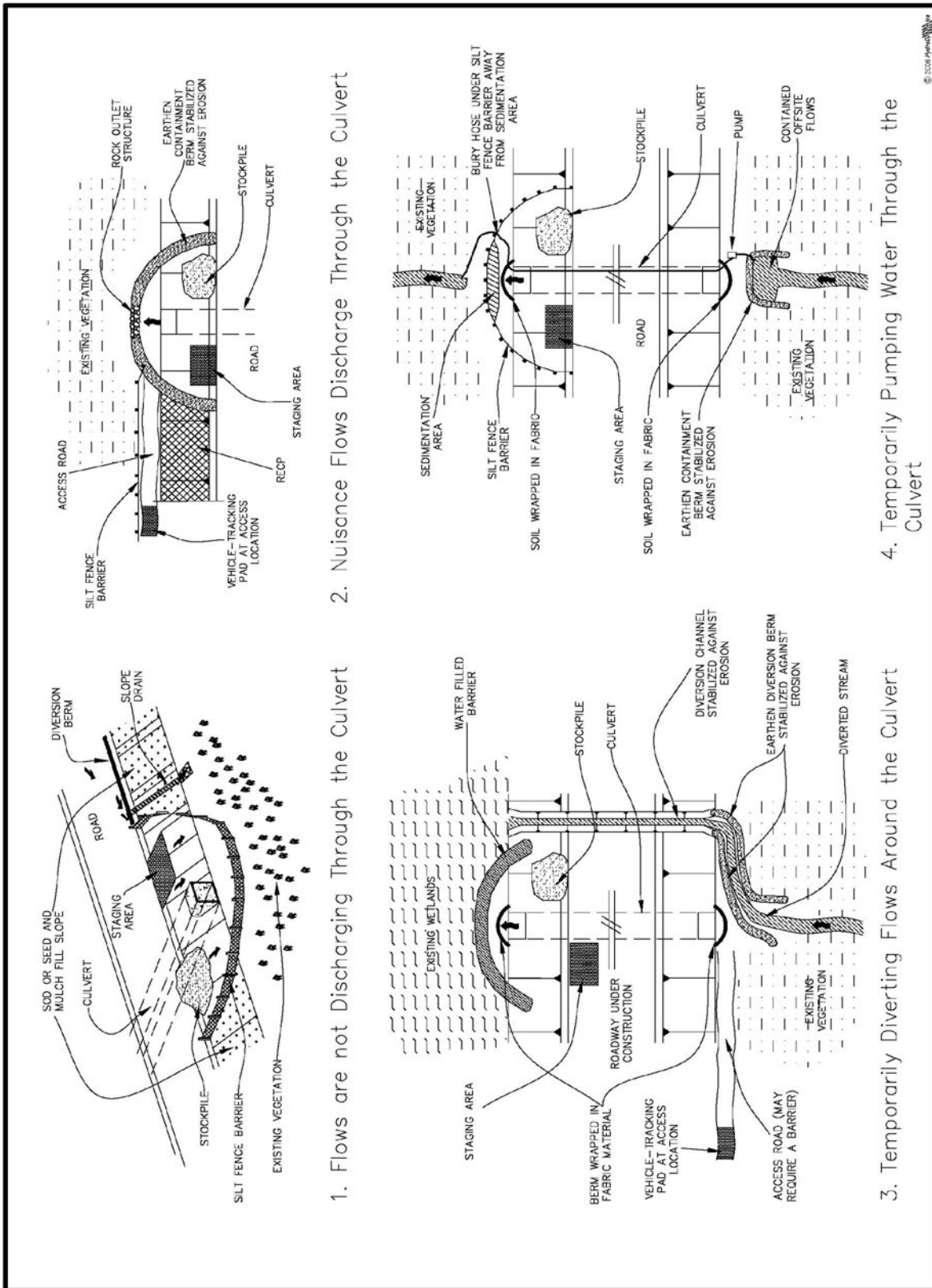

Figure V-21: Illustration of Using BMPs While Building Box Culverts

Permission is given by HydroDynamics Incorporated to copy and reproduce this detail

**APPENDIX I.**  
**COASTAL APPLICATIONS**

## **INTRODUCTION**

### ***Overview of Coastal Settings***

Construction sites in a coastal environment present unique challenges because of the direct link to sensitive water bodies and the limited available area to implement erosion and sediment control practices. Coastal settings are often subject to higher wind speeds, saline-laden air moisture, and wave action that require the selection of appropriate erosion control practices that can withstand these elements. Florida is partially surrounded by coastline and is often a target for tropical depressions, storms, and hurricanes. In addition, approximately 77% of Florida's population lives in coastal areas, necessitating continuous development of roads and infrastructure along Florida's coastline. Thus, there is a significant need for erosion and sediment control practices which can be adapted to coastal environments.

### ***Purpose and Overview***

This Appendix presents technologies available to designers, hydrologists, and construction personnel for mitigating erosion and sedimentation in coastal areas of Florida. The technologies are divided into two groups, Erosion Control Technologies and Sediment Containment Technologies. Temporary and permanent control technologies are presented for each group. The information provided for each technology includes:

- A description of the technology.
- The general purpose(s) of the technology.
- Considerations for implementation of the technology in coastal areas.
- When the technology should be installed.
- Where and when the technology should not be installed.
- Inspection and maintenance needs.

Additional specifications and steps for implementation of many of the technologies are provided in Sections I through V of this manual.

### ***Design Considerations for Coastal Settings***

Coastal environments present a number of challenges to infrastructure design, construction practices, and implementation of erosion and sediment control which are unlike challenges found in inland environments. These challenges often necessitate longer design processes, careful consideration and research of expected environmental conditions, and using designers and construction contractors who are experienced in coastal environments. Some of the elements to consider when designing infrastructure and developing erosion control plans are:

- Materials must be resistant to salt spray and contact with saline water.
- Coastal areas often have a high water table; excavation activities are therefore restricted. As a result, sediment containment ponds are often unpractical.
- Soil compaction and site preparation are difficult due to sandy, non-cohesive soils. In addition, sandy soils are easily transported in runoff.
- Coastal soils are typically alkaline and nutrient-poor, which provides a difficult medium for establishing soil-stabilizing vegetation. Selected vegetation must be salt-tolerant.
- Coastal areas are typically high-energy environments due to exposure to wind and waves; selected erosion control practices therefore must be resistant to these elements.



- Frequent maintenance of erosion and sediment control practices may be needed due to high exposure and damage potential.
- Tidal fluctuations can limit the area available for construction and for erosion and sediment control.
- Coastal watersheds can be large and difficult to delineate due to small changes in elevation, and it can be difficult to accurately estimate design storm runoff and to design proper erosion control features.
- Coastal geology in southern Florida is typically dominated by limestone rock (a.k.a. limerock). Limerock can be exposed to air and water during site excavation and roadbed construction. During storm events, the limerock can be easily eroded, resulting in milky-colored stormwater filled with fine sediment that is difficult to flocculate.
- Coastal environments in Florida are widely varied. Environments such as estuaries, inlets, open shoreline, reef-protected shoreline, and lagoons have different conditions, including wave energy, wind exposure, tidal fluctuations, and cross-currents. These conditions must be thoroughly evaluated for each site prior to the design of erosion control features.

This Appendix provides guidance to the designer or construction contractor when selecting appropriate erosion and sediment control technologies for coastal areas. However, much of the material presented is also applicable to interior lands. General design and technology sizing information is provided in Sections I through V of this manual. Where possible, detailed design information related to coastal environments is presented in the technology summaries that follow.

## **EROSION CONTROL TECHNOLOGIES**

### ***Temporary Controls***

#### **Compost/Wood Mulching**

-- *A mixture of compost, wood mulching, bark, or other vegetative material applied to an area. Materials include: shredded wood (wood chips, wood bark, wood cellulose fiber, and wood excelsior) and other organic material (vegetative trimmings such as grass, shredded shrubs, and trees).* --

#### **What is its Purpose?**

- To reduce soil erosion through temporary soil stabilization.
- To protect exposed soil from wind and raindrop impact.
- To decrease velocity of runoff over exposed soil areas, thereby increasing infiltration.
- To provide an appropriate medium for the growth of seeds for further stabilization.

#### **Where and How is it Commonly Used in Coastal Areas?**

- Can be applied to exposed soil surfaces, often up to the soil/water interface.
- May be applied by hand or by mechanical methods.
- Best performance is on slopes 1:5 (*V:H*) or flatter.
- Caution should be used when applying mulch or compost at the soil/water interface because of the potential for sedimentation of the water body.
- If on-site vegetation is used, ensure that invasive species such as melaleuca and Brazilian pepper are removed from the site prior to grinding or shredding of existing vegetation.
- If shredded wood is used, evenly distribute material across the soil surface to a depth of 2 to 3 inches. Desired application rates are as follows:
  - Wood chips or bark: 4 to 6 tons per acre
  - Wood cellulose fiber: 0.5 to 1.0 tons per acre

- Wood excelsior: 2 tons per acre
- If vegetative trimmings are used, evenly distribute material across the soil surface to a depth of not more than 2 inches. Application rates vary widely based on source of material.
- Vegetative trimmings, wood cellulose fiber, and wood excelsior are the best choices if the soil surface is to be seeded, since seed germination is often difficult under a thick, heavy wood chip or bark cover.
- The application of a soil binder is required in most coastal areas to maintain placement of mulch. Follow guidelines for soil binder selection and application rates under “Soil Binders” in this Appendix.

**When Should it be Installed?**

- While construction activities are occurring.
- After construction activities are completed.

**Where and When Should it not be Installed?**

- Areas with heavy wave action or concentrated flows.
- Slopes greater than 1:3 (*V:H*).
- Areas with high tidal fluctuations.
- Avoid placement of mulch on pavement, sidewalks, existing or expected drainage channels, and on existing vegetation.

**What Needs to be Inspected?**

- All areas of application on a weekly basis, particularly after a heavy storm or wave action.

**What Maintenance Activities can be Expected?**

- Bare areas must be re-covered with mulch/compost immediately, or if removal is somewhat uniform, reapply when more than 20% of ground is exposed in application area.

*Notes*

- Wood fiber mulches are typically short-lived.
- Undesirable weeds can be introduced in the mulch.
- Possible introduction of organic (tannic) acids and dissolved organic carbon from decaying plant material to nearby coastal water bodies can occur.

## Design Example

### *Photos of Application*



Wood and bark mulch (Source: KCSWCD, 2006)  
2007)



Wood excelsior fiber close-up (Source: Wholesale Supplies,

### *Design Example*

See design example under “Hydraulic Mulch” in this Appendix.

## Hydraulic Mulch

-- *A mixture of shredded wood fiber or a bonded fiber matrix and a soil binder such as a stabilizing emulsion, tackifier, or lineal non-toxic polymer, applied with specialized hydro-mulching equipment. Common soil binders included in hydraulic mulch are acrylic polymer, guar gum, and psyllium (plantago).* --

### **What is its Purpose?**

- To reduce soil erosion through temporary soil stabilization.
- To protect exposed soil from wind and raindrop impact.
- To decrease velocity of runoff over exposed soil areas and increase infiltration.
- To provide an appropriate medium for the growth of seeds for further stabilization.

### **Where and How is it Commonly Used in Coastal Areas?**

- Most applicable for temporary stabilization of surfaces that are either expected to be re-disturbed at a later time or are expected to be treated with permanent stabilization measures.
- Typically applied by hydraulic methods.
- For most effective soil stabilization and coverage, exposed soil surface should be loose (un-compacted) at time of application. Soil areas can be roughened by rolling the surface with a crimping or punching-type roller or by track walking to increase the soil surface area available for binding to the hydraulic mulch.
- Exposed soil areas should be covered completely.
- Choose a tackifier/binder that does not introduce contaminants into the adjacent water body.

- Follow guidelines for selection and application rates of binders under “Soil Binders” in this Appendix.
- Typical hydraulic mulch application rates are as follows:
  - Wood fiber mulch: 2,000 – 4,000 lbs/acre
  - Wood fiber with acrylic polymer or other binder: 2,000 – 4,000 lbs/acre wood fiber mulch with 5-10% by weight of binder
  - Bonded fiber matrix with acrylic polymer: 3,000 – 4,000 lbs/acre
- See individual manufacturer’s recommendations for mixture specifications and desirable moisture content of hydraulic mulches.
- Binders *may* require up to a 24-hour cure time to be effective, so weather patterns should be closely monitored during and immediately after application. However, required curing time can vary widely and can be binder-specific. For example, lineal non-toxic binding polymers do not require a cure time. Always check manufacturer’s recommendations prior to use of a soil binder in hydraulic mulch.

**When Should it be Installed?**

- While construction activities are occurring.
- After construction activities are completed.

**Where and When Should it not be Installed?**

- Not suitable for areas with high wave energy (average wave height > 1.2 feet) or concentrated flows.
- Area of application is limited in areas with high tidal fluctuations.

**What needs to be Inspected?**

- Inspect areas of application after a heavy storm or heavy wave action
- Look for bare areas where mulch/compost was removed.

**What Maintenance Activities can be Expected?**

- Bare areas must be re-covered with mulch/compost immediately, or if removal is somewhat uniform, reapply when more than 20% of ground is exposed in application area.

*Notes*

- Avoid spraying hydraulic mulch on adjacent water body or existing vegetation.
- Some materials are susceptible to removal or disturbance by wind in exposed areas.
- Wood fiber hydraulic mulches are typically short-lived.
- Undesirable weeds can be introduced in mulch.

## Design Example

### *Photos of Application*



Hydraulic mulch sprayer (Source: Price and Company, 2006) Dyed hydraulic mulch (Source: Terra-Mulch, 2006)

### *Design Example*

A designer on a 25-acre coastal construction project selects hydraulic mulch for temporary soil stabilization as construction activities are phased across the site. She selects fiber hydraulic mulch with a 10% (by weight) polyacrylamide binder content. She identifies the maximum expected high tide elevation during the construction period prior to establishment of permanent erosion controls and marks this point as the limit of the area to be mulched. The volume of hydraulic mulch and binder needed are calculated as follows:

*Weight of mulch needed = Exposed area x Mulch application rate*

*Weight of mulch needed = 25 acres x 1.5 tons/acre*

***Weight of mulch needed in mix = 37.5 tons***

## Soil Binders

-- Similar to hydraulic mulch, but material includes only a stabilizing emulsion, tackifier, or polymer. General categories of soil binders are plant-based (short- and long-lived), polymeric emulsion blends, cementations binders, lineal non-toxic polymer of high molecular weight, and dry polymeric binders. Typical soil binders are guar gum, psyllium (plantago), starch, pitch/rosen mixture, acrylic copolymer, methacrylate, acrylate, sodium acrylate, polyacrylamide, hydro-colloid polymer, and gypsum. --

### **What is its Purpose?**

- To prevent soil erosion through temporary soil stabilization.

### **Where and How is it Commonly Used in Coastal Areas?**

- Can be used for temporary stabilization of sandy soils in areas with high erosive potential or potential for wind erosion.
- Soil binders tend to work well in areas with high relative humidity, which is typical of coastal areas.
- Typically applied by hydraulic equipment. In some cases, binders may be applied as dry powder with a hand or mechanical spreader, but only when recommended by the manufacturer.
- **Table 1** shows properties of commonly-used soil binders.
- For most effective soil stabilization and coverage, exposed soil surface should be loose (un-compacted) at time of application.
- Exposed soil surface may need to be pre-wetted prior to application. Check binder manufacturer's recommendations.
- Area may need to be crowned or sloped to avoid ponding of binder.
- Avoid spraying binder on adjacent water body, existing vegetation, sidewalks, and roadways.
- Exposed soil areas should be covered completely.
- The selected binder should not introduce contaminants to the adjacent water body and should be non-toxic to plant and animal life.
- Longer cure times (>24 hours) may be needed with some types of binders due to high humidity and salt-laden moisture in coastal areas. Check binder manufacturer's recommendations. Lineal non-toxic polymers, which can be used for binding, tackification, and water clarification, do not require a cure time.
- More than one treatment layer may be necessary.
- Some materials are susceptible to removal or disturbance by wind in exposed areas.
- Some binders require at least a 24-hour cure time to become effective, so weather patterns should be closely monitored during and immediately after application. However, required curing time can vary widely and can be binder-specific. Always check manufacturer's recommendations prior to application of a soil binder.
- See Appendix III for further discussion of polymer flocculants and binders.

### **When Should it be Installed?**

- During construction activities, can be used in areas that need short-term stabilization and will soon be re-worked or re-graded.

### **Where and When Should it not be Installed?**

Not suitable for areas with high energy environment (average wave height > 1.2 feet), concentrated flows, or high tidal fluctuations.

- Not suitable long-term unless combined with another treatment measure.

- Not suitable for areas where contaminants from soil binder can be introduced to nearby coastal water bodies.
- Should not be used in areas expected to have heavy pedestrian or vehicular traffic.

**What needs to be Inspected?**

- Inspect areas of application after a heavy storm or heavy wave action.
- Examine area for bare areas where binder has undergone spot failure or has been removed.
- A sampling and analysis plan and associated inspection plan should be implemented by the designer to ensure binder is not leaching to adjacent water body at the soil/water interface.

**What Maintenance Activities can be Expected?**

- Bare areas must be re-covered with binder immediately, or if removal is somewhat uniform, reapply when more than 20% of ground is exposed in application area.

*Notes*

- Documentation of toxicity testing may be required if a polymer is selected as a soil binder, especially in biologically-sensitive coastal areas. See Appendix III for further information.

**Table 1.** Properties of Soil Binders for Erosion Control (Source: CalTrans, 2004).

Evaluation criteria	Binder type					
	Plant material based (short lived)	Plant material based (long lived)	Polymeric emulsion blends	Cementations binders	Lineal non-toxic polymer	Dry polymeric binders
Relative cost	low	low	low	low	low	low
Resistance to leaching	high	high	low to moderate	moderate	low to moderate	low to moderate
Resistance to abrasion	moderate	low	moderate to high	moderate to high	moderate to high	moderate to high
Longevity	short to medium	medium	medium to long	medium	medium to long	medium to long
Minimum curing time before rain	9 to 18 hours	19 to 24 hours	0 to 24 hours	4 to 8 hours	no cure time	no cure time
Compatibility with existing vegetation	good	poor	poor	poor	good	good
Labor intensive	no	no	no	no	no	no
Specialized application equipment	water truck or hydraulic mulcher	water truck or hydraulic mulcher	water truck or hydraulic mulcher	water truck or hydraulic mulcher	water truck or hydraulic mulcher	hand or mechanical spreader
Liquid/powder	powder	liquid	liquid/powder	powder	liquid/powder	powder
Surface crusting	yes, but dissolves on rewetting	yes	yes, but dissolves on rewetting	yes	yes, but dissolves on rewetting	yes, but dissolves on rewetting
Clean up	water	water	water	water	water	water



**Design Examples**

*Photos of Application*



Soil tackifier applied by sprayer truck (Source: SoilTac, 2006)



Soil binder and seed mixture applied near coastal bay (Source: SoilTac, 2006)

**Design Example**

Mock Site Plan

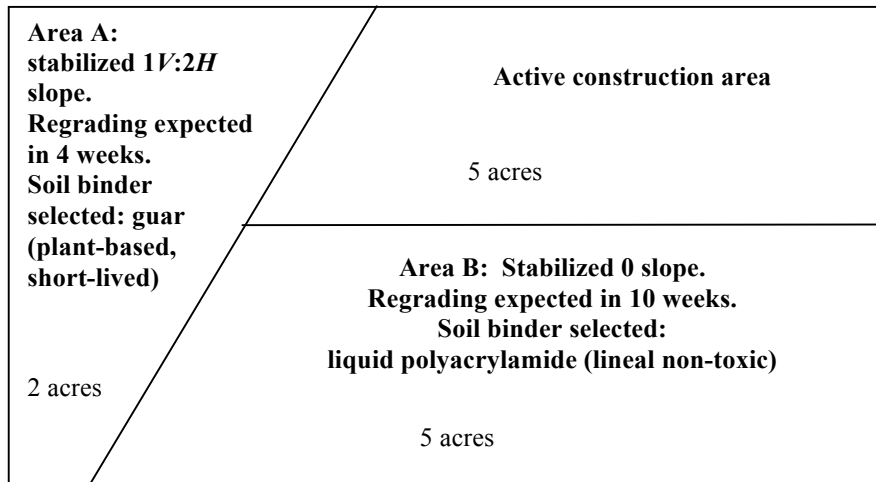

A designer on a 12-acre coastal construction project selects two soil binders for temporary soil stabilization as construction activities are phased across the site. The amount of binder needed is calculated as follows:

**Area A: Guar soil binder**

*Weight of binder needed = Exposed area x manufacturer-recommended binder application rate*

*Weight of binder needed = 2 acres x 60 lbs/acre (example for soil and slope conditions)*

**Weight of binder needed = 120 lbs**

**Area B: Polyacrylamide soil binder**

*Weight of binder needed = Exposed area x manufacturer-recommended binder application rate*

*Weight of binder needed = 5 acres x 5 lbs/acre (example for soil and slope conditions)*

**Weight of binder needed = 25 lbs**

### Temporary Hydroseeding

-- *Hydroseeding is the application of a mixture of water, wood fiber, seed, fertilizer, and a soil stabilizer to temporarily protect exposed areas of soil from erosion due to wind, rain, and runoff. Common seed types used in Florida are bahia, bermuda, bahia/bermuda mix, and annual type ryegrass. Additional seed types that are being tested by the Natural Resource Conservation Service, and may soon become available, for use in temporary or permanent stabilization of soil in construction areas are: eastern gamagrass, lopsided indiagrass, chalky bluestem, hairawn muhly, switchgrass, and wiregrass (NRCS, 2006).* --

#### **What is its Purpose?**

- To reduce soil erosion through temporary soil stabilization.
- To provide an appropriate medium for the growth of seeds for further stabilization.

#### **Where and How is it Commonly Used in Coastal Areas?**

- Seeds are applied using a hydroseeder.
- Seeds that are tolerant to salt water and salt-laden moisture should be selected. In addition, chosen plants should be able to grow quickly in mineral soils with few nutrients.
- Refer to guidelines under “Establishing Permanent, Salt-Tolerant Vegetation” in this Appendix for selecting appropriate seed types for hydroseeding in coastal areas. The designer should always consult with a local agronomist on selection of appropriate seed types.
- For most effective coverage, exposed soil surface should be loose (un-compacted) at time of application. Soil areas can be roughened by rolling the surface with a crimping or punching-type roller or by track walking to increase the soil surface area available for seeding.
- For best results, cover hydroseed layer with a mulch layer to keep applied seeds in place, retain soil moisture, and control soil temperature during seed establishment. Follow guidelines for selection and application rates for mulch under “Hydraulic Mulch” in this Appendix.
- The application of a soil binder may be necessary to further stabilize hydraulic mulch and seed to allow for germination and continued growth of vegetation. Follow guidelines for binder selection and application rates under “Soil Binders” in this Appendix.
- Due to the lack of nutrients in most coastal soils, hydroseeding may need to be used in conjunction with another measure such as the application of mulch and fertilizer in order for the seeds to germinate and become effective in reducing erosion.
- Fertilizers should be included only when soil tests indicate a lack of adequate nutrients to establish and sustain the selected vegetation.
- If fertilizers and/or soil stabilizers are used, additional sediment control measures must be implemented to retain materials on-site and limit transport to and contamination of adjacent water bodies.

#### **When Should it be Installed?**

- While construction activities are occurring.
- After construction activities are completed.

#### **Where and When Should it not be Installed?**

- Avoid application of hydroseed on existing vegetation, water bodies, sidewalks, and roadways.
- Should not be used in areas where re-disturbance is expected within 4-6 weeks.

#### **What needs to be Inspected?**

- Inspect area before a precipitation event to make sure it is properly protected.
- Inspect area after a precipitation event and/or heavy wind for any removal of vegetation, mulch, or other stabilization material.

### What Maintenance Activities can be Expected?

- Repair coverage and re-apply hydroseed material as needed to maintain maximum protection against erosion.
- If plant seeds fail to germinate, or established plants die, area must be re-seeded. Consider consulting with an agronomist for selecting other seed types if widespread failure of plants occurs.

### Notes

- The temperate climate of most coastal areas in Florida allows for an extended growing season in which seeding can be applied.
- Depending on the type of seed selected, the temporary vegetation applied through temporary hydroseeding may have to be removed prior to the application of permanent seeding.

### Design Examples

#### *Photos of Application*



Hand application of hydroseed on construction sites (Source: RMB Craftscapes Ltd, 2006)

### ***Permanent Controls***

#### Polymer-Enhanced Armoring

-- *Armoring is the permanent stabilization of a coastline or streambank that is eroding or susceptible to erosion, using natural or organic materials often in conjunction with a soil stabilizer such as a polymer. Armoring includes nourishing beaches with sand or shells, constructing marshlands, planting submerged aquatic vegetation, planting grass/sod or other salt-tolerant vegetation, and installing natural fiber logs. Possible combinations include:*

- *Rip-rap, jute-mat with polyacrylimide, and sod or grass seed.*
- *Low-profile rock or rubble with marsh vegetation.*
- *Oyster reefs with stone containment groins.*
- *Geo-grid material with implanted marsh vegetation.*
- *Beach replenishment with living breakwater (low profile breakwater made with marine limestone rock and oysters). –*
-

**What is its Purpose?**

- To reduce soil erosion through permanent soil stabilization in low to medium energy environments (average wave height < 1.2 feet).
- In some cases, to slow the velocity of runoff to a water body.

**Where and How is it Commonly Used in Coastal Areas?**

- Armoring can be used to dampen wave impact and to protect shorelines from erosion.
- Armoring can be used when construction is conducted in coastal areas to protect shorelines from greater runoff volumes.
- Some armoring techniques can serve as a filtration system for removing sediment in runoff prior to transfer to the adjacent water body.
- Armoring can preserve or provide for more habitat for benthic, estuarine, shallow water, and inter-tidal organisms.
- The area protected should extend well beyond and below the expected high and low tidal elevations to provide adequate erosion protection and undercutting of the medium.

**When Should it be Installed?**

- While construction activities are occurring.
- After construction activities are completed.

**Where and When Should it not be Installed?**

- High energy environments (average wave height > 1.2 feet) with heavy wave action and wind.
- Areas where access is limited and maintenance is costly.

**What needs to be Inspected?**

- Inspect area before a precipitation event to make sure it is properly protected.
- Inspect area after a precipitation event, heavy wind, and/or high water event for any removal of media.

**What Maintenance Activities can be Expected?**

- Repair coverage and re-apply media as needed to maintain maximum protection against erosion.
- If failure of media occurs routinely, consider another type or size of protective media.

**Design Examples**

*Photos of Application*



Armoring with oyster habitat and constructed wetlands  
(Source: NOAA, 2006)



Armoring on beach with jute netting and salt-tolerant vegetation (Source: Foundation Technologies, 2006)

## ***Case Study: Polymer-Enhanced Armoring***

### ***Damage to U.S. Highway 98 from Hurricane Dennis, Florida Panhandle, 2005***

*Information provided by Josh Boan (FDOT), Michael Shepard (FDOT), and Steve Iwinski (Applied Polymer Systems, Inc.), 2006.*

On July 10, 2005, Hurricane Dennis raged through the Florida Panhandle near Apalachicola and St. George's Island. It made landfall at 3 pm as a Category 3 Hurricane with a maximum sustained wind near 140 mph. U.S. Highway 98, a major tourism and transportation corridor that snakes along the Panhandle's coastline, was a prime target for hurricane damage.



*Path of Hurricane Dennis, July 2005. Area of greatest damage on US Highway 98 was in the east-central portion of the Florida Panhandle.*

Damage was severe on approximately 14 miles of U.S. Highway 98, ranging from erosion of the shoulder to buckling and subsidence of the entire roadway.



*Front slope and shoulder damage on highway, July 12, 2005*



*Full roadway damage on a portion of highway, July 12, 2005*

Immediately, the Florida Department of Transportation (FDOT) took action to re-construct and open traffic on the stretch of damaged highway and awarded a construction contract to complete emergency repairs within 14 days. Travel lanes were reconstructed and traffic soon resumed; within a month, however, shoulder erosion was reoccurring, threatening to again encroach on travel lanes.



*Evidence on sheet erosion and undercutting of sod, August 2005*



*Sheet and gully erosion along shoulder, August 2005*

FDOT immediately sought to implement a short-term (1-2 years) solution to protect the roadway and minimize sheet erosion of shoulders until a more permanent plan could be developed. Due to the proximity of the highway to the ocean and high exposure to saline-laden moisture and wind, any vegetation used to stabilize the shoulders and front slopes would have to be able to resist harsh environments.

FDOT consulted with Applied Polymer Systems and developed a polymer-enhanced armoring countermeasure that was cost-effective and met design objectives. The design consisted of the following elements:

- Removal of existing turf and grading of shoulders and front slopes
- Compost – 2” depth
- Jute fiber erosion control blanket
- Polyacrylamide (PAM) powder (Silt Stop, QPL#M-0203) – applied at a rate of 50 lbs/acre
- Vegetation – bermuda grass sod
- Temporary silt fence installed at base of front slope or shoulder

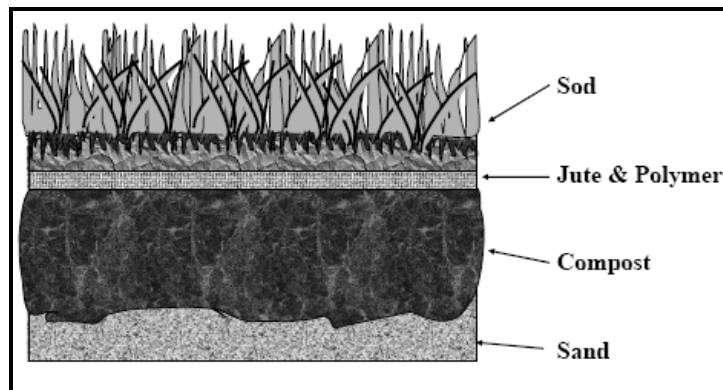

*Cross-sectional schematic of armoring design layers used on U.S. Highway 98 (Applied Polymer Systems, 2006)*



*Placement of compost mulch layer*



*Placement of jute fiber erosion control blanket*



*Placement of bermuda grass sod over jute blanket*



*Final placement of sod*

The jute erosion control blanket provided an initial attachment surface for the PAM powder. The soil-specific PAM reacted with metals and fine, clay-sized particles, binding the soil together and promoting flocculation of fines that were transported in stormwater runoff. The polymer/soil complex further bound to the jute mat and surrounding soil in the compost and sod layers, creating a highly erosion-resistant matrix that allowed the establishment of vegetation.

One year later (August 2006), the polymer-enhanced armoring technique is performing well, requiring little maintenance and successfully mitigating coastal erosion. Over time, the jute blanket is expected to biodegrade, and the sod vegetation will continue to establish roots in the underlying topsoil.



*Armoring in place, one year later*



*Roadway and shoulder successfully protected*

### Establishing Permanent, Salt-Tolerant Vegetation

-- *Establishing permanent vegetation through seeding, sodding, or transfer of adult plants that are tolerant to low-nutrient mineral soils and saline moisture. Common seed types used in Florida are bahia, bermuda, bahia/bermuda mix, and annual type ryegrass. Additional seed types that are being tested by the Natural Resource Conservation Service for temporary or permanent stabilization of soil in construction areas and soon may be available for use are eastern gamagrass, lopsided indiagrass, chalky bluestem, hairawn muhly, switchgrass, and wiregrass (NRCS, 2006). Common sod types used in (but not native to) Florida are centipede, bahia, and bermuda sod.* --

#### **What is its Purpose?**

- To protect exposed soil from wind and raindrop impact.
- To provide a long-term, aesthetically pleasing, natural erosion-resistant environment during or after construction activities.

#### **Where and How is it Commonly Used in Coastal Areas?**

- Seeds that are tolerant to salt water and salt-laden moisture should be selected. In addition, chosen plants should be able to grow quickly in mineral soils with few nutrients.
- This section serves only as a guide. Consultation with an agronomist or landscape architect who is familiar with the area is highly recommended prior to selecting an appropriate plant species. Likewise, the bulk availability of the plant should be verified through the Association of Florida Native Nurseries via their website: [www.afnn.org](http://www.afnn.org).
- In addition to the grass types listed in the description above, plant species that are native to Florida and are able to grow well in low- to high-salt environments are listed in **Table 2**.
  - Plants that are considered to have “**good**” salt tolerance are very resistant to salt drift and moisture and should be selected for highly exposed environments.
  - Plants that are considered to have “**moderate**” salt tolerance are resistant to some salt drift and moisture but should be protected by structures, fences, or more salt-tolerant plant species.
  - The geographical range in Florida is indicated by: **n** = north, **c** = central, **s** = south.
- Plant seeds can be applied by hand or hydroseeder.
- For most effective coverage, exposed soil surface should be loose (un-compacted) at time of application. Soil areas can be roughened by rolling the surface with a crimping or punching-type roller or by track walking to increase the soil surface area available for seeding.
- For best results, cover seeds or plants with a light, coarse mulch layer to keep applied seeds in place, to retain soil moisture, and to control soil temperature during seed establishment. Follow guidelines for selection and application rates for mulch under “Hydraulic Mulch” in this Appendix.
- The application of a soil binder may be necessary to stabilize hydraulic mulch and seed to allow for germination and continued growth of vegetation. Follow guidelines for binder selection and application rates under “Soil Binders” in this Appendix.
- Due to the lack of nutrients in most coastal soils, seeding may need to be used in conjunction with another control measure, such as the application of mulch and fertilizer, in order for the seeds to take hold and become effective in reducing erosion.
- Fertilizers should be used only when soil tests indicate a lack of adequate nutrients to establish and sustain the selected vegetation.
- Another method of rapid soil stabilization while allowing native plant species to develop is to lay sod along the exposed soil area and plant small, native plants by hand within small perforations of the sod. The native plants eventually over-grow and out-compete the surrounding sod for available nutrients.



**Table 2.** Salt-Tolerant Native Plant Species in Florida (Source: David Chiappini, 2006)

<b>Common name</b>	<b>Scientific name</b>	<b>Area of Florida</b>	<b>Relative salt tolerance</b>
Youpon Holly	<i>Ilex vomitoria</i>	n, c, s	good
Southern Red Cedar	<i>Juniperus silicicola</i>	n, c, s	good
Wax Myrtle	<i>Myrica cerifera</i>	n, c, s	good
Sand Pine	<i>Pinus clausa</i>	n, c	good
Live Oak	<i>Quercus virginiana</i>	n, c, s	good
Sand Live Oak	<i>Quercus geminata</i>	n, c, s	good
Dahoon Holly	<i>Ilex cassine</i>	n, c, s	moderate
Southern Magnolia	<i>Magnolia grandiflora</i>	n, c, s	moderate
Florida Red Bay	<i>Persea borbonia</i>	n, c	moderate
Slash Pine	<i>Pinus elliottii</i>	n, c, s	moderate
Sycamore	<i>Platanus occidentalis</i>	n, c	moderate
Chickasaw Plum	<i>Prunus angustifolia</i>	n, c	moderate
Cherry Laurel	<i>Prunus caroliniana</i>	n, c	moderate
Laurel Oak	<i>Quercus laurifolia</i>	n, c, s	moderate
Water Oak	<i>Quercus nigra</i>	n, c	moderate
Bald Cypress	<i>Taxodium distichum</i>	n, c, s	moderate
Christmas Berry	<i>Lycium carolinianum</i>	n, c, s	good
Cabbage Palm	<i>Sabal palmetto</i>	n, c, s	good
Saw Palmetto	<i>Serenoa repens</i>	n, c, s	good
Spanish Bayonet	<i>Yucca aloifolia</i>	n, c, s	good
Adams Needle	<i>Yucca filamentosa</i>	n, c, s	good
Gallberry	<i>Ilex glabra</i>	n, c, s	moderate
Paurotis Palm	<i>Acoelorrhapha wrightii</i>	c, s	moderate
Groundseltree	<i>Baccharis halimifolia</i>	c, s	good
Devil's Backbone	<i>Pedilanthus tithymaloides</i>	c, s	moderate
Dune Sunflower	<i>Helianthus debilis</i>	n, c, s	good
Beach Morning Glory	<i>Ipomoea pes-caprae</i>	n, c, s	good
Virginia Creeper	<i>Parthenocissus quinquefolia</i>	n, c, s	good
Purslane	<i>Portulaca sp</i>	n, c, s	good
Sea Oats	<i>Uniola paniculata</i>	n, c, s	good
Coontie	<i>Zamia pumila</i>	n, c, s	good
Seaside Paspalum	<i>Paspalum vaginatum</i>	n, c, s	good
Blanket Flower	<i>Gaillardia pulchella</i>	n, c	moderate
Mahogany	<i>Swietenia mahogani</i>	s	good

Pigeon Plum	<i>Coccoloba diversifolia</i>	s	good
Satin Leaf	<i>Chrysophyllum oliviforme</i>	s	good
Silver Buttonwood	<i>Conocarpus erectus</i>	s	good
Inkberry	<i>Scaevola plumieri</i>	s	good
Marlberry	<i>Ardisia escallonioides</i>	s	good
Sea Grape	<i>Coccoloba uvifera</i>	s	good
Saltmeadow Cordgrass	<i>Spartina patens</i>	n, c, s	good
Upland River Oats	<i>Chasmanthium latifolium</i>	n, c	good
Black Mangrove	<i>Avicennia germinans</i>	n	good
Red Mangrove	<i>Rhizophora mangle</i>	n, c, s	good
White Mangrove	<i>Laguncularia racemosa</i>	c, s	good
White Stopper	<i>Eugenia axillaris</i>	c, s	good
Spanish Stopper	<i>Eugenia foetida</i>	c, s	good
Leather Fern	<i>Acrostichum danaeifolium</i>	s	good
Smooth Cordgrass	<i>Spartina alterniflora</i>	n, c	good
Sand Cordgrass	<i>Spartina bakeri</i>	n, c, s	moderate
Virginia Dropseed	<i>Sporobolus virginicus</i>	n, c, s	good
False Rosemary	<i>Conradina canescens</i>	n, c	moderate
Rusty Lyonia	<i>Lyonia ferruginea</i>	n, c	moderate
Muhly Grass	<i>Muhlenbergia capillaries</i>	n, c	moderate
Myrtle Oak	<i>Quercus myrtifolia</i>	n, c	moderate
Tough Bumelia	<i>Sideroxylon tenax</i>	n, c	moderate
Devilwood	<i>Osmanthus americanus</i>	n, c	moderate
Beautyberry	<i>Callicarpa americana</i>	n, c, s	moderate
Hercules Club	<i>Zanthoxylum clava-herculis</i>	n, c	moderate
Sparkleberry	<i>Vaccinium arboreum</i>	n, c	moderate
Railroad Vine	<i>Ipomoea pes-caprae</i>	n, c, s	good
Longleaf Pine	<i>Pinus palustris</i>	n, c	moderate
Sweetgum	<i>Liquidambar styraciflua</i>	n, c, s	moderate
Jamaica Dogwood	<i>Piscidia piscipula</i>	s	good
Blackbead	<i>Pithecellobium keyense</i>	s	good
Sea Lavender	<i>Argusia gnaphalodes</i>	s	good
Bay Cedar	<i>Suriana maritima</i>	s	good
Florida Privet	<i>Forestiera segregata</i>	n, c, s	moderate
White Indigoberry	<i>Randia aculeata</i>	c, s	moderate
Joewood	<i>Jacquinia keyensis</i>	s	moderate

**When Should it be Installed?**

- While construction activities are occurring.
- After construction activities are completed.

**Where and When Should it not be Installed?**

- Not recommended for steep slopes.
- Should not be used in areas that expect additional construction activities within 4 – 6 weeks.

**What needs to be Inspected?**

- Inspect area before a precipitation event to make sure it is properly protected.
- Inspect area after a precipitation event and/or heavy wind for any removal of vegetation, mulch, or other stabilization materials.

**What Maintenance Activities can be Expected?**

- Repair coverage and re-apply plants as needed to maintain maximum protection against erosion.
- If plant seeds fail to germinate, or established plants die, area must be re-seeded. Consider another seed type if widespread failure of plants occurs.
- The construction contractor or designer must be responsible for the health of the selected plants until they are established regardless of time and resources. The expected establishment or warranty period should be specified in the landscape plan. Once the contractor deems the vegetation established, a properly-qualified official should inspect the site and determine if additional erosion protection is needed.
- A detailed maintenance plan should be prepared by the designer or construction entity and delivered to the landowner regarding the proper care of the selected plants after establishment. The intent of plant selection and placement that was presented in the landscape plan should be re-iterated in the text of the maintenance plan.

*Notes*

- Transplant of adult plants can be more expensive and more labor-intensive but can provide for more protection, particularly on steeper slopes and sand dunes. The planting process for larger plants typically disturbs more soil than for smaller plants. For example, the typical planting of an adult plant requires excavating a hole that is 3 to 5 times the width of the plant's rootball (Jeff Caster, 2006). When selecting plants, carefully consider the size of the construction area, the extent of exposure of the coastal area to wind, rain, and concentrated flows, and cost of plants and labor to install plants.
- A detailed landscape plan should be prepared and approved prior to the start of construction. The landscape plan should identify location, quantity, and planting time of plants to be used for erosion control.
- If fertilizers and/or soil stabilizers are used, additional stormwater control measures must be implemented to retain materials on-site and to limit transport and contamination of adjacent water bodies.

## Design Examples

### *Photos of Application*



*Sea oats (Source: Univ. of FL, 2006)*



*Black mangrove (Source: NRCS, 2006)*

### Preserving Existing Vegetation

-- *Planning construction activities so that existing trees and natural vegetated areas are avoided and protected.* --

#### **What is its Purpose?**

- To preserve existing vegetation on a construction site, thereby providing permanent soil stabilization and natural filtration of stormwater runoff.
- To provide a long-term, aesthetically-pleasing, natural erosion-resistant environment during and after construction activities.
- To limit maintenance needs by taking advantage of established vegetation.

#### **Where and How is it Commonly Used in Coastal Areas?**

- A detailed landscape plan should be prepared by a qualified person and approved prior to the start of construction. The landscape plan should clearly identify the location and quantity of vegetation to be preserved during the construction process.
- During construction, protect existing areas of vegetation that are not in direct conflict with construction activities by installing physical barriers or placing highly visible fencing.
- Planning construction activities for the height of the growing season will allow for the greatest erosion protection and visualization of the extent of existing vegetation to be protected.
- Care should be taken not to disturb tree roots.
- If roots are disturbed, they should be covered with soil and/or mulch immediately.
- For best results, cover areas immediately adjacent to existing vegetation with a thin mulch layer to help absorb erosive energy of concentrated flows caused by construction practices, to retain soil moisture, and to control soil temperature. Follow guidelines for selection and application rates for mulch under “Hydraulic Mulch” or “Compost/Wood Mulching” in this Appendix.

- The application of a soil binder may be necessary to further stabilize adjacent hydraulic mulch. Follow guidelines for binder selection and application rates under “Soil Binders” in this Appendix.
- After construction, aerate soil that is compacted from construction activities.

**When Should it be Installed?**

- Before construction activities begin.
- While construction activities are occurring.

**Where and When Should it not be Installed?**

- Not applicable.

**What needs to be Inspected?**

- Inspect area prior to start of construction activities to ensure vegetated areas to be avoided are properly marked and protected.
- Inspect area periodically during construction for encroachment of construction activities into protected areas and for any breach in fencing or other barrier.

**What Maintenance Activities can be Expected?**

- Maintain fencing and barriers as needed.
- Inspect existing vegetation for signs of stress. If needed, apply seed or transplant vegetation to maintain natural vegetative covering where possible.
- A detailed maintenance plan should be prepared by the designer or construction entity and delivered to the landowner regarding care of existing plants after construction is complete. The intent of plant preservation that was presented in the landscape plan should be re-iterated in the maintenance plan.

***Notes***

- After areas to be protected are marked, area available for construction activities may be limited.
- Requires additional time in the planning process to locate, mark, and plan activities around vegetated areas.

**Design Examples**

*Photos of Application*



*Natural coastal vegetation, Caribbean  
(Source: University of West Indies, 2006)*



*Natural coastal vegetation in Biscayne Bay, Florida  
(Source: TerraGalleria, 2006)*



*Protected tree on construction site, with fencing outside dripline  
(Source: Treescape, 2006)*



*Marked tree preservation area in construction zone  
(Source: National Gallery, 2006)*

**Design Example**

**Mock Site Plan**

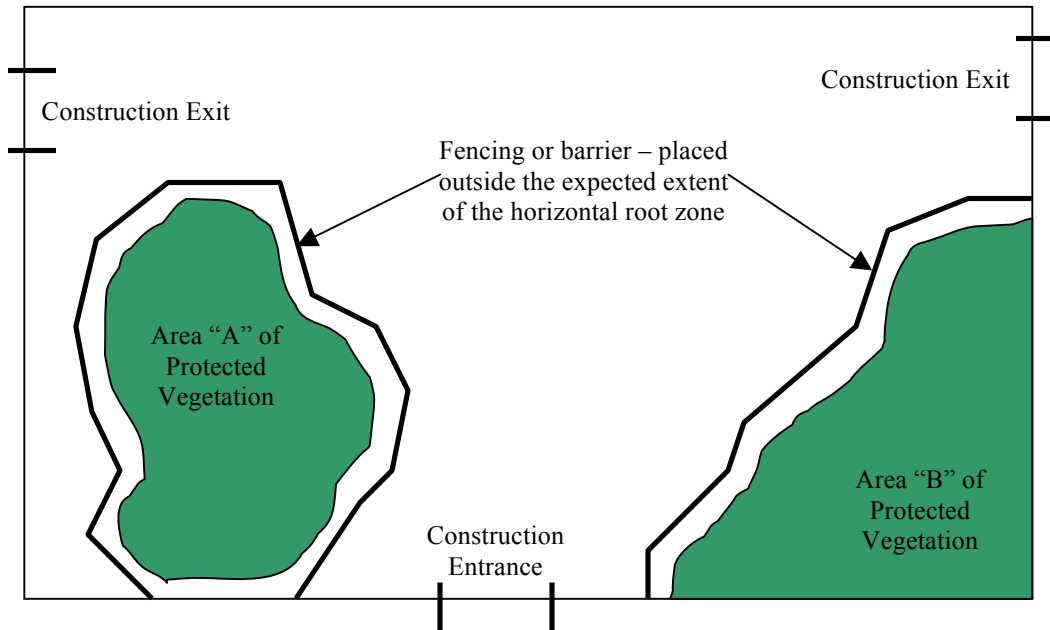

A designer on a coastal construction project wishes to protect existing coastal vegetation to limit erosion in areas that will not be graded. The designer clearly marks and fences off areas to be protected (see mock site plan). Area A includes several small trees, so the fencing is placed just outside the trees' drip lines or canopy extent, which is expected to be similar to the extent of the root zone. Area B contains a large tree, and guidelines state that protective fencing should be placed 1 foot away for every 1 inch diameter of the tree, with a minimum of 10 feet. The tree is 24 inches in diameter, so fencing is placed at least 24 feet away from the edge of the tree. Where possible, construction site entrances and exits are located well away from areas of protected vegetation.

Minimum Fencing Guidelines for Tree Protection (Source: City of Urbana, IL, 2006):

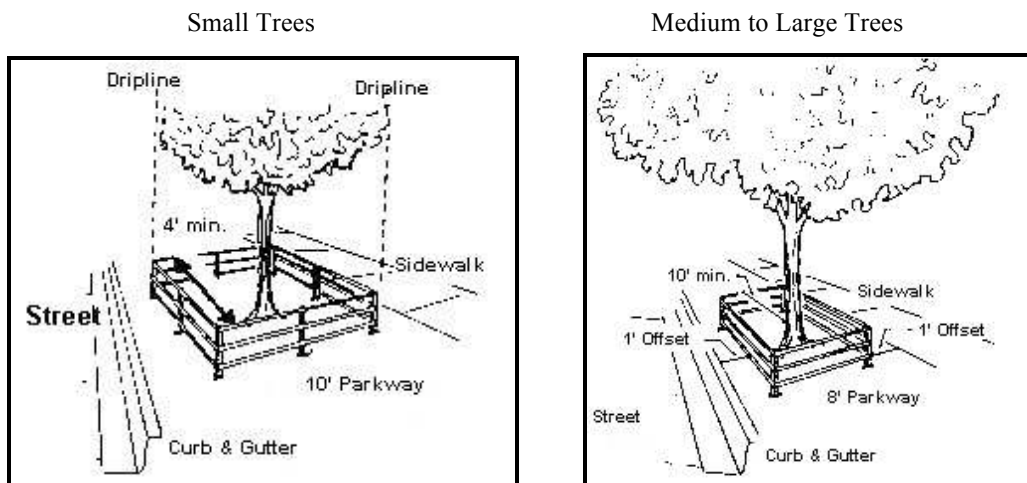

### Construction Site Barrier

-- *Installing a permanent barrier at the soil/water interface to protect construction area from erosion and to limit sediment transfer to adjacent water body. Types of barriers include sheet piles, concrete walls, or earthen dikes.* --

#### **What is its Purpose?**

- To protect construction area from erosion due to waves, tides, and runoff.
- To limit sediment leaving a construction site and transfer to an adjacent water body.

#### **Where and How is it Commonly Used in Coastal Areas?**

- Barriers should be designed to provide protection over the full range of tidal fluctuations and a reasonable design storm surge.
- A temporary barrier may be placed while the permanent barrier is installed landward of the temporary barrier.
- Installation of barrier is specific to type of barrier.

#### **When Should it be Installed?**

- Before construction activities begin.
- While construction activities are occurring.

#### **Where and When Should it not be Installed?**

- In areas where coastal wildlife habitat must not be disturbed.
- In areas where the maintenance of landscape aesthetics is a priority.

#### **What needs to be Inspected?**

- Inspect area periodically during construction for any breach in barrier, particularly any breaches or openings that allow passage of water and subsequent erosion and/or transfer of sediment from construction site to water body.

#### **What Maintenance Activities can be Expected?**

- Maintain and re-construct barriers as needed.

#### *Notes*

- Area available for construction activities may be limited after placement of barrier.
- Installation of barriers may be equipment- and labor-intensive.
- Development of a plan using this method may require the professional skills of a structural engineer.



## Design Examples

### *Photos of Application*



Coastal construction along US Hwy 1, Key West, FL  
(Source: James Smoot, 2006)



Protection of construction site using sheet-pile barrier and jute fiber mat (Source: Foundation Technologies, 2006)

### *Design Example*

A designer on a coastal construction project needs to determine the expected range of tide elevations at the site over the period of construction—June 15 – September 30, 2007—to correctly locate and design a construction site barrier. The construction site is near Naples, FL.

The designer visits the National Oceanic and Atmospheric Administration (NOAA) website:

[http://tidesandcurrents.noaa.gov/station\\_retrieve.shtml?type=Historic+Tide+Data](http://tidesandcurrents.noaa.gov/station_retrieve.shtml?type=Historic+Tide+Data)

The designer selects a nearby tidal station by scrolling through the list of stations on the website. Once the station is selected, actual tidal data from the previous 2 days can be viewed. To pull predicted values for tide elevations for the period of construction, the designer selects the “Tide Predictions” tab on the left side of the screen (see screen capture). The designer selects the dates of the planned period of construction and can view a graphical or tabular summary of hourly tide elevations for that period.

From the predicted data for the construction period, the expected maximum high tide elevation is 3.60 feet above mean low-low water elevation. The expected minimum low tide elevation is 1.00 foot below mean low-low water elevation. Therefore, there is an expected tide range of 4.60 feet during the construction period.

The designer can specify the height of the barrier so that it rises well above the expected maximum high tide elevation to protect the construction site from erosion from waves and tides.

Another NOAA web resource for current and historical data from tidal monitoring sites is as follows:  
<http://tidesonline.nos.noaa.gov/geographic.html>

*Design Example, cont.*

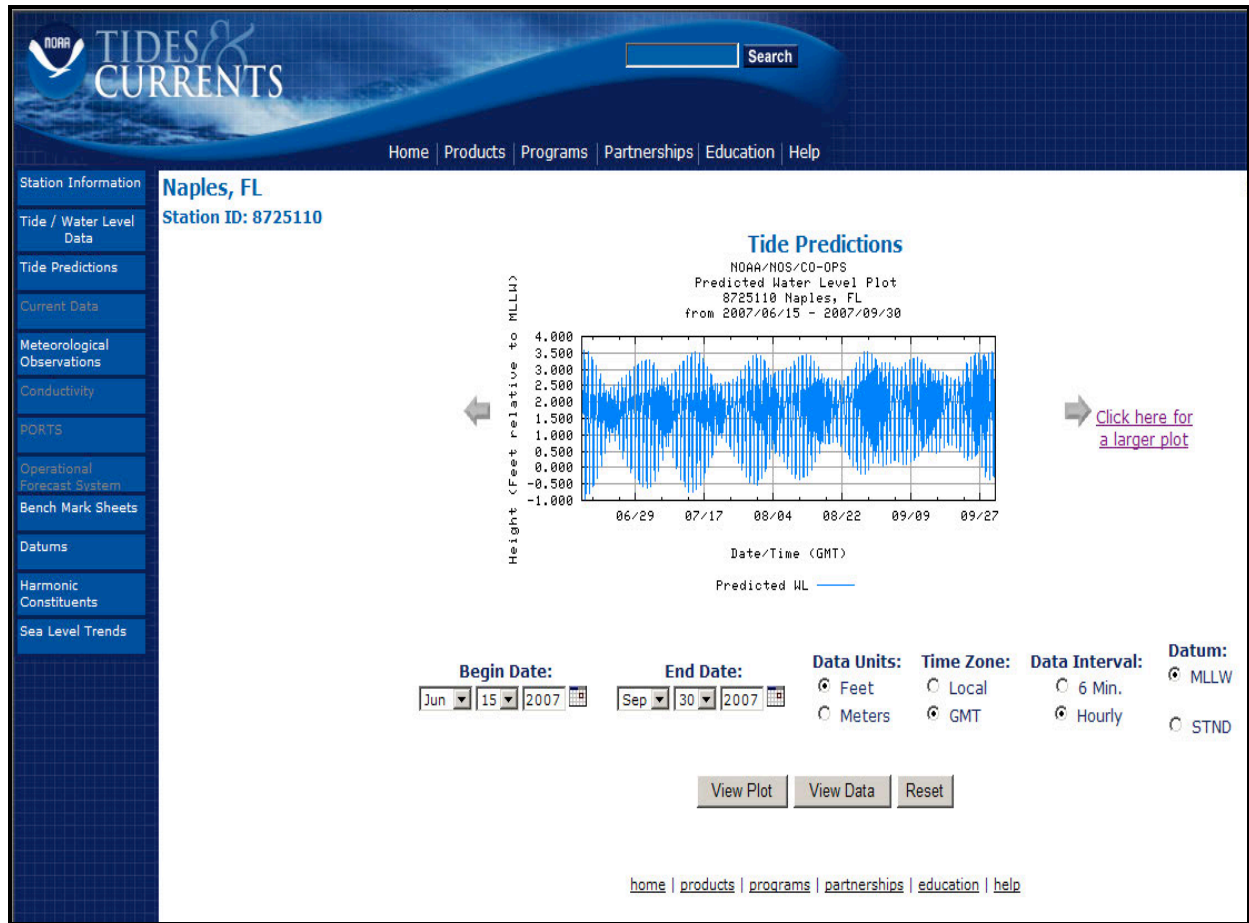

Screen capture of Tide Predictions website for tidal monitoring station #8725110 at Naples, FL (Source: NOAA, 2006)

### Geotextiles, Mats, and Geogrids

-- *A natural or synthetic material used to control soil erosion from wind and water. The material can be formed into fibrous mats, blankets, soil-filled socks, or interlocking grids. Common materials include:*

- *Natural: excelsior, straw, jute, coconut fiber*
- *Synthetic: metal geogrid, polyethylene*

*Seeds, fertilizers, and polymer such as polyacrylamides (PAM) can be applied in conjunction with the geomaterial. See Appendix III for further discussion of polymer flocculants. --*

#### **What is its Purpose?**

- To protect construction area from erosion due to waves, tides, raindrop impact, and concentrated runoff.
- To provide a medium for the growth of seedlings when establishing permanent vegetation.

#### **Where and How is it Commonly Used in Coastal Areas?**

- Geotextiles and mats are most applicable in a coastal area not directly impacted by waves. Selected geomaterial should be resistant to saline water and moisture.
- Sand-filled geosocks can be used to protect large, sensitive construction areas from erosion and to limit sediment transfer to the water body, but should be removed after construction.
- Geotextiles and mats can be used in conjunction with an armoring technique (see “Polymer-Enhanced Armoring” in this Appendix).
- Growth of vegetation is often slow in some coastal environments due to nutrient-poor soils. Geomaterials are useful for establishing a long-term, protective growth medium for seedlings.
- In coastal areas frequented by wildlife, a geotextile without plastic netting should be used. Wildlife can become entangled in plastic or non-breakable netting.
- Site preparation and grading are critical. Geomaterials should be installed in direct, continuous contact with the underlying soil layer.
- Rocks, large vegetation, and debris should be removed from soil prior to installation of geomaterial.
- The top 2–3 inches of soil should be loosened or aerated to provide a good seed bed for vegetation establishment.
- Installation of geomaterial is highly specific to the type of material and setting.

#### **When Should it be Installed?**

- While construction activities are occurring.
- After construction activities are completed.

#### **Where and When Should it not be Installed?**

- Geogrids should not be located in areas with high recreational use due to tripping hazards.
- Cannot be used in excessively steep or rough slopes.
- Not suitable for areas with heavy pedestrian traffic.

#### **What needs to be Inspected?**

- Inspect area before a precipitation event to make sure it is properly protected.
- Inspect area after a precipitation event and/or heavy wind for any removal of geomaterial or additional cover material such as mulch.
- If staples are installed, ensure that they are securely connected and flush with the ground.
- Check any lap joints for proper overlap of materials. Ensure there are no open spaces between segments of geomaterial. Open spaces can channelize runoff and result in concentrated erosion of soil at the lap joints.

### What Maintenance Activities can be Expected?

- Repair coverage and re-apply geomaterial, additional cover, and seed as needed to maintain maximum protection against erosion.
- Ensure that geomaterial maintains contact with the underlying soil.
- If plant seeds fail to germinate, or established plants die, area must be re-seeded. Consider another seed type if widespread failure of plants occurs.

### Design Examples

#### *Photos of Application*



*Jute fiber geomat in Broward County, FL  
(Source: Applied Polymer Systems, 2000)*



*Sandsock, sand-filled tubular geotextile  
(Source: Surfrider Foundation, 2006)*

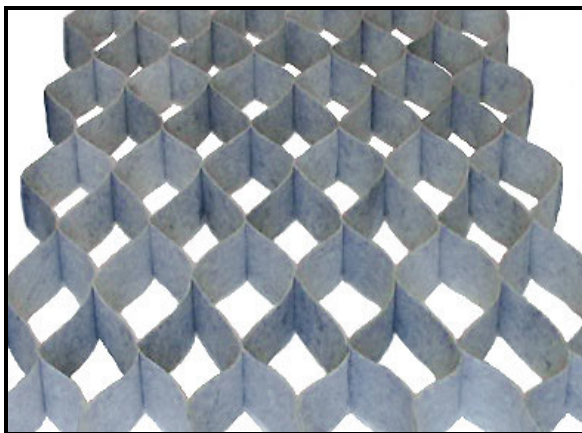

*Metal geogrid (Source: IECA, 2006)*



*Metal geogrid being installed for beach stabilization  
(Source: IECA, 2006)*

## **SEDIMENT CONTAINMENT TECHNOLOGIES**

### **Floating Turbidity Barrier**

-- *A temporary silt barrier consisting of a floating tubular segment with a filter fabric extending into the water column and weighted at the bottom.* --

#### **What is its Purpose?**

- To retain sediment and floating debris from a construction area at the water's edge so that removal or containment is possible.

#### **Where and How is it Commonly Used in Coastal Areas?**

- Most applicable for use in low energy environments such as estuaries and reef-protected shorelines.
- Can also be used in relatively shallow offshore construction and excavation activities to control migration of suspended sediment.
- Floating turbidity barriers are available in three types: Type I, Type II, and Type III. All types are applicable to environments with flow velocity less than or equal to 5 feet per second. Further specifications are as follows:
  - Type I, Light Duty: Intended for low-energy environments with little or no current, wind, or wave action.
  - Type II, Moderate Duty: Intended for environments with some current (<3.5 feet per second) and with some exposure to wind.
  - Type III, Heavy Duty: Intended for environments with greater current (3.5 – 5.0 feet per second) and with moderate exposure to wind and wave action.
- The barrier should be securely anchored to shore at both ends.
- Longer-term construction projects may require that more than one line of barrier is used, as additional protection against migration of sediment and debris.
- The bottom of the barrier should be weighted by a chain or cable weighing 1.1 pounds per linear foot, and each 100 feet length of barrier requires a 24 pound anchor.
- The floating segment should be at least 6 inches in diameter.

#### **When Should it be Installed?**

- Before construction activities begin.
- While construction activities are occurring.

#### **Where and When Should it not be Installed?**

- Should not be used in high energy environments (average wave height > 1.2 *ft*).

#### **What needs to be Inspected?**

- Inspect area after a precipitation event and heavy wind for any breach in the floating barrier; check condition of shore anchors and underwater anchors.
- Migration of floating barriers is common if not properly secured and maintained.

#### **What Maintenance Activities can be Expected?**

- Breaches must be repaired immediately.
- Routinely remove large debris from the barrier to prevent breaching.
- Upon completion of construction or replacement of barrier, remove sediment and debris along with the barrier. Allow at least 24 hours after a precipitation and runoff event before removal of barrier to allow sediment time to settle.

*Notes*

- Removal of suspended sediment from the controlled area may be difficult and costly.
- Turbidity barrier cannot be constructed of materials that entraps or entangles wildlife, particularly manatees. Barrier must not restrict manatee access to manatee habitat.

**Design Examples**

*Photos of Application*



Turbidity barrier along US Hwy 1, Key Largo, FL  
(Source: Molly Wood, 2006)



Turbidity barrier and substantial trapped sediment along  
Maryland coast (Source: IECA, 2006)

*Design Example*

See Section III: Temporary Construction Site BMPs for design specifications on floating turbidity barriers.

### **Sediment Retention Barrier (SRB)**

*-- A temporary barrier constructed of two rows of silt fence, 4 to 6 feet apart, filled with compost, wood mulch, wood chips, or other vegetative material mixed with a polymer flocculant to enhance sediment removal. --*

#### **What is its Purpose?**

- To slow runoff.
- To retain sediment and other pollutants transported in runoff, enhancing water quality of stormwater that passes through the SRB.

#### **Where and How is it Commonly Used in Coastal Areas?**

- Can be installed close to the soil/water interface or at the seaward side of construction activities to slow runoff and trap sediment from construction site.
- Used in coastal areas with water-quality concerns in addition to sediment.
- Drainage area upstream from SRB should be limited to 1 acre/100 *ft* of silt fence.
- Silt fence should allow a water passage rate of 70 *gpm/ft<sup>2</sup>*.
- Filter fabric must be entrenched into underlying soil; otherwise, undercutting will occur.
- The SRB must be installed along slope at zero grade and perpendicular to flow, never up- and down-slope. Fence can channelize and divert runoff if not installed at zero grade.
- Silt fence must be installed so the top of the fence is level in order to adequately retain water and avoid fence failure.
- Ends of silt fence should be continued up-slope so runoff does not flow around ends of fence.
- Allow sufficient space up-slope from the SRB for ponding of water.
- Seams between sections of silt fence should be wrapped and rolled together and staked. See sections I through V for additional guidance.
- The loose mulch or other vegetative material placed inside the SRB should be at least 3 feet deep and should not be compacted.
- The dry polymer flocculants should be applied to and mixed with the loose mulch using a hand spreader.
- See Appendix III for further discussion of polymer flocculants and polymer-enhanced SRBs.

#### **When Should it be Installed?**

- Before construction activities begin.

#### **Where and When Should it not be Installed?**

- In areas where large volumes and rates of runoff are expected.
- Cannot be installed within the tidal zone or where contact with waves is expected.

#### **What needs to be Inspected?**

- Inspect area after a precipitation event for any tears or splits in the fabric material, movement of posts, undercutting of fabric, detachment of fabric from posts, and removal of material between the layers of silt fence.
- Inspect area after a precipitation event for buildup of sediment.

#### **What Maintenance Activities can be Expected?**

- Damaged areas must be repaired immediately.
- SRB may be removed when areas up-slope are permanently stabilized and water-quality of runoff is no longer a significant concern in the area.
- When sediment reaches one-half the height of the silt fence, the sediment should be removed.

**Notes**

- During larger storm events, temporary flooding can occur on the upstream side of the silt fence.
- Design life of silt fence is short (5–8 months if properly installed).

**Design Examples**

**Photos of Application**



SRB prior to placement of mulch barrier  
(Source: Florida Dept. of Envr. Protection, 1988)



SRB with shredded wood mulch and polymer  
(Source: Manoj Chopra, 2006)

**Design Example**

See Appendix III: Polymer and Alum for design specifications on SRBs.

**Compost Filter Berms**

-- *A temporary or permanent ridge of erosion-resistant material at the base of a slope of exposed soil or in any location where runoff of eroded soil should be restricted. Typical berm materials include shredded wood (wood chips, wood bark, wood cellulose fiber, and wood excelsior) and organic material (vegetative trimmings such as grass, shredded shrubs, and trees). Examples of compost filter berms that have been implemented in the eastern U.S. are as follows:*

- *Mesh sock stuffed with coarse bark, wood chips, fine-shredded wood or vegetal fiber suited for seed germination.*
- *Berm constructed of fine, shredded wood and other recycled organic material and installed by a patented pneumatic machine which forms, compacts, and automatically stabilizes the berm with a soil binder. --*

**What is its Purpose?**

- To retain eroded soil on-site.
- To restrict movement of runoff and any eroded soil.
- To channelize runoff to a desired location, perhaps directing it away from the most disturbed areas.



**Where and How is it Commonly Used in Coastal Areas?**

- The filter berm should be constructed near the soil/water interface in coastal areas, but care should be taken to keep the berm above the expected high tide elevations.
- Berms can be constructed above and below the areas of construction, to restrict clean water from moving over any areas of exposed soil and to restrict runoff from entering the nearby water body.
- If berm is designed to re-direct runoff, water can be channelized to a sedimentation pond or other treatment feature. Protect outlets to treatment features with riprap or vegetation, depending on the volume of runoff re-directed. See Sections I through V for additional guidance.
- Compaction of the soil/compost material is necessary.
- Minimum recommended grade of slope where berm is to be installed is 1%.
- The berm should be constructed with an ideal 1V:2H ratio to maintain stability of berm. Common berm sizes and specifications are listed in **Table 3**.
- Berms shall be installed on level contours at zero slope to ensure perpendicular sheet flow.
- If concentrated flows are expected, encase compost in a stabilizing material such as a mesh sock and stake every 10 linear feet.
- The ends of the berm must be constructed to point upslope (ends at higher elevation than remainder of berm) to prevent water from circumventing the berm.
- If possible, berms should be installed on a level surface at a distance of 5 *ft* or greater from the toe of the slope to maximize the area available for sediment deposit behind the berm. It may be necessary to install a second berm behind the initial berm to restrict flow and allow for adequate space for sediment deposit.
- Berm should be immediately seeded with salt-tolerant vegetation to reduce erosion of the berm. Follow guidelines presented under “Establishing Permanent, Salt-Tolerant Vegetation” in this Appendix.

**Table 3.** Compost Berm Specifications (Source: Filtrexx, 2006)

<i>Slope</i>		<i>Maximum slope length</i>	<i>Berm size required</i>	<i>Approx. berm length per cubic yard of material</i>
(percent)	(ratio, <i>V:H</i> )	(linear feet)	(height × width)	(linear <i>ft</i> )
0%-2%	flatter than 1:50	250	1 <i>ft.</i> x 2 <i>ft.</i>	19
2%-10%	1:50-1:10	125	1 <i>ft.</i> x 2 <i>ft.</i>	19
10%-20%	1:10-1:5	100	1 <i>ft.</i> x 2 <i>ft.</i>	19
20%-33%	1:5-1:3	50	1.3 <i>ft.</i> x 2.6 <i>ft.</i>	10
>50%	>1:2	25	1.5 <i>ft.</i> x 3 <i>ft.</i>	7.6

NOTE: To obtain a copy of this information, go to [www.filtrexx.com](http://www.filtrexx.com); on the left side of the screen, click on Specs & Designs; then click on Compost Filter Berms-Silt Fence Alternative; then click Open when prompted; and open the Word file titled, “Filtrexx Berm SpecMaster 1-15-03.doc.” Web site and documentation are subject to change.

- Compost used for berms should have the following characteristics:
  - Free of weeds, refuse, contaminants, or other materials toxic to plant growth
  - Derived from a well-decomposed source of organic matter

- pH between 5.0 and 8.0
  - Particle size between ½” and 2” (99% passing through a 2” sieve and a minimum of 70% not passing through a 3/8” sieve)
  - Moisture content less than 60%
  - Must comply with local, state, and federal regulations.
- If on-site vegetation is used as material for the berm, ensure that invasive species such as melaleuca and Brazilian pepper are removed from the site prior to grinding or shredding of existing vegetation.
  - Application of a soil binder on the berm surface may be necessary in areas with high wind and rain exposure. Follow guidelines for selection and application rates of binders under “Soil Binders” in this Appendix.

**When Should it be Installed?**

- Before construction activities begin.
- While construction activities are occurring.

**Where and When Should it not be Installed?**

- Cannot be placed below high tide elevations.
- Should not be used in areas with high wind exposure unless a soil/compost binder is applied to maintain placement of berm.

**What needs to be Inspected?**

- Inspect berm after precipitation events or heavy wave action for erosion.
- Inspect berm to ensure vegetation is becoming established.

**What Maintenance Activities can be Expected?**

- Eroded areas must be re-filled, compacted, and re-covered with mulch immediately.
- The contractor should remove collected sediment when it reaches one-half of the exposed height of the filter berm.

**Design Examples**

*Photos of Application*



Compost filter berm in sandy soils (Source: Rexius, 2006)



Detail of compost-filled mesh sock (Source: Filtrexx, 2006)



Installation of compost berm (Source: Rexius, 2006)

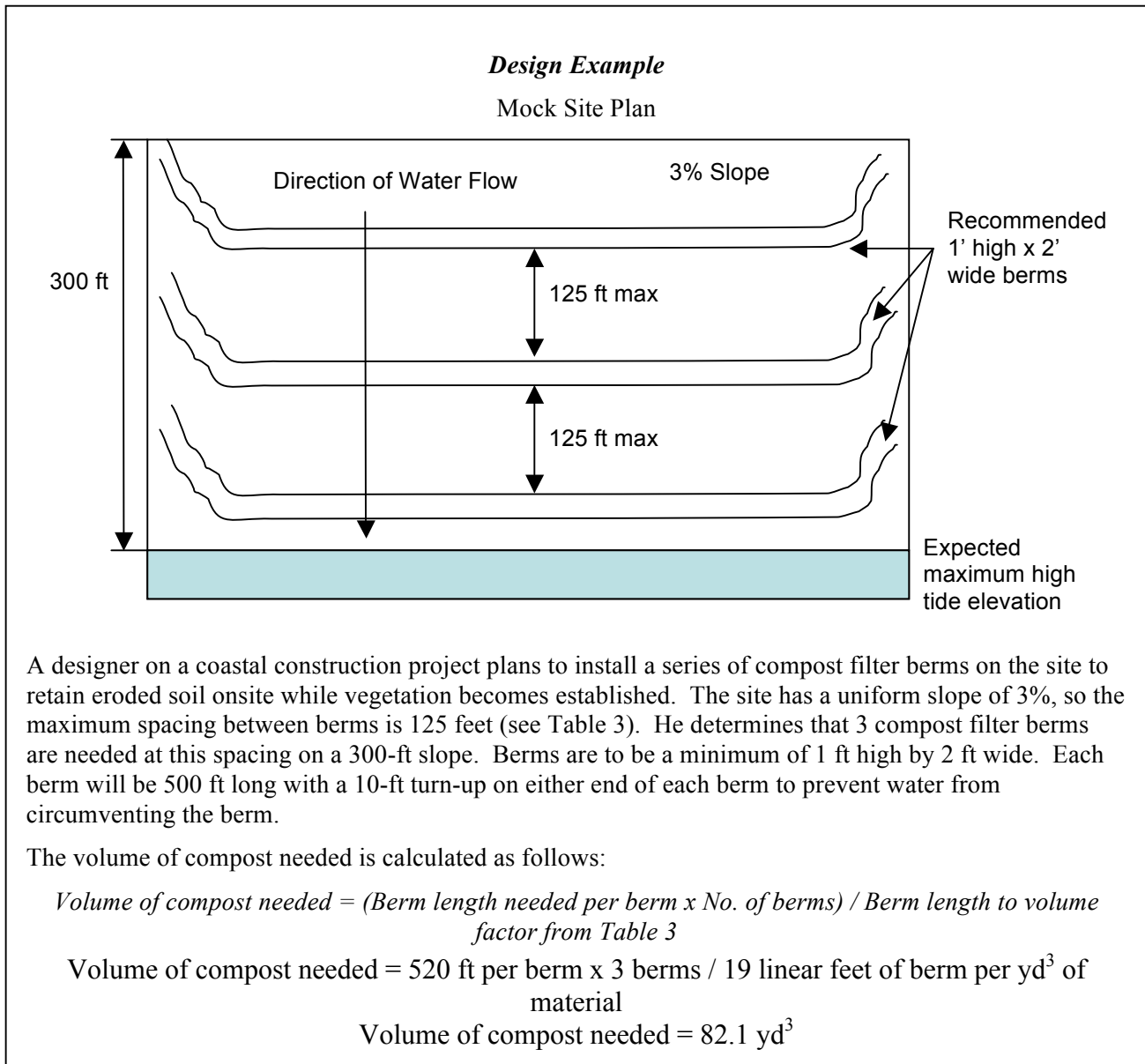

## REFERENCES

1. Applied Polymer Systems, 2000, file photograph
2. Applied Polymer Systems, 2006, Website, <http://www.siltstop.com/index.html>
3. Association of Florida Native Nurseries, 2006, Website, <http://www.afnn.org>
4. Boan, Josh; Shepard, Michael; and Iwinski, Steve, 2006, US 98 Soft Armor Countermeasures Utilizing Polymer Technology, Florida Department of Transportation and Applied Polymer Systems, Presentation at the FICE/FDOT Design Conference, Orlando, FL.
5. CalTrans, 2004, California Stormwater Best Management Practices Manual, Handbook 1 of 11 (Construction).
6. Caster, Jeff, 2006, State Transportation Landscape Architect, Florida Department of Transportation, personal communication.
7. Chiappini, David, September 2006, Chiappini Farm Native Nursery, personal communication via Florida Department of Transportation.
8. Chopra, Manoj, 2006, Associate Professor, University of Central Florida, personal photograph.
9. City of Urbana, Illinois, November 2006, Website, <http://www.ci.urbana.il.us>
10. Filtrexx International, September 2006, Website, <http://www.filtrexx.com/index.htm>
11. Florida Department of Environmental Protection, 1988, The Florida Stormwater, Erosion, and Sedimentation Control Inspector's Manual.
12. Foundation Technologies, Inc., November 2006, Website, <http://www.foundationtechnologies.com/>
13. International Erosion Control Association (IECA), July 2006, Website, <http://www.ieca.org/>
14. Kennebec County Soil and Water Conservation District (KCSWCD), Kennebec, Maine, August 2006, Website, <http://www.kcswcd.org/>
15. National Oceanographic and Atmospheric Association (NOAA), August 2006, Ocean and Coastal Resource Management, Website, <http://coastalmanagement.noaa.gov/>
16. National Gallery of Art, November 2006, Site Construction Website, <http://www.nga.gov>
17. Natural Resource Conservation Service (NRCS), July 2006, U.S. Department of Agriculture, Website, <http://plant-materials.nrcs.usda.gov>
18. North Carolina Department of Environment and Natural Resources (NCDENR), August 2006, Division of Forestry Services, Website, <http://www.dfr.state.nc.us>
19. Price and Company, August 2006, Website, <http://www.priceandcompany.com/>
20. Rexius Erosion Control Systems, September 2006, Website, <http://www.ecoberm.com/>
21. RMB Craftscapes Ltd, July 2006, Website, <http://www.hydroseeding.co.uk/>
22. SoilTac Corporation, July 2006, Website, <http://www.soiltac.com>
23. Smoot, James, 2006, Regional Associate Hydrologist, U.S. Geological Survey, personal photograph.
24. Surfrider Foundation, August 2006, Website, <http://www.surfrider.org>
25. TerraGalleria, November 2006, Website, <http://terragalleria.com>

26. Terra-Mulch, November 2006, Website, <http://terra-mulch.com>
27. Treescape, November 2006, Website, <http://www.treescape.org>
28. University of Florida, July 2006, Department of Horticulture, Website, <http://hort.ufl.edu>
29. University of West Indies, Cave Hill, August 2006, Department of Pure and Applied Sciences, Website, <http://scitec.uwichill.edu.bb/>
30. Wholesale Supplies, January 2007, Website, <http://www.wholesalesupplies.com>
31. Wood, Molly, 2006, Hydrologist, U.S. Geological Survey, personal photograph.

**APPENDIX II.**  
**DEWATERING OPERATIONS**

## **INTRODUCTION**

### ***Overview of Dewatering Operations***

Dewatering operations are an important component in the construction process and receive special attention from the local water management agencies. The removal of suspended sediment and the reduction of the associated turbidity in water produced as a part of dewatering operations provide unique challenges at construction sites. This is primarily because of the possibility of adverse impacts to receiving water bodies and often because of the limited land area available for which to implement control practices. Regulators are especially concerned with the protection of nearby wetlands from drawdown effects and protecting the receiving water body from sedimentation and possible capacity limitations.

The waters associated with dewatering operations are highly variable in their quality and are associated with highly varying geological materials and other environmental influences. Construction sites in Florida are often subject to high water-table conditions and require the employment of various dewatering activities and associated practices to locally lower groundwater levels to facilitate excavation and construction activities and to manage these waters and other waters on the site.

### ***Types of Dewatering Methods***

In Florida, the following three types of dewatering methods are most commonly used:

**Rim-ditching** – Rim-ditching is a method where a ditch is excavated along the inside perimeter of the excavation area and a pump is used to keep the level of the ground water below the bottom surface of the excavation. This type of dewatering method is usually the least expensive of the methods, requiring only a trash pump and backhoe. However, it produces the dirtiest water, which must be treated prior to offsite discharge. While rim ditching may be the cheapest method of construction dewatering, potential costs of water treatment prior to discharge may result in much higher costs.

**Sock pipe/Horizontal wells** – This method of dewatering includes the installation of perforated plastic pipes, usually wrapped in geofabric, in a horizontal fashion on the inside of the excavation pit. The plastic pipes are then attached to a pump. While this method is more expensive to install than the traditional rim ditching, it does produce significantly cleaner discharge water. Initial installation of the sock pipe is limited to 15-20 feet; however, deeper dewatering depth can be achieved in phases. The use of sock pipe is limited in clay soils.

**Well-point systems** – This method of dewatering includes the installation of multiple shallow wells that are attached to a main collection pipe attached to a central pump. Well-point systems are typically used in linear projects such as installation of pipelines and culverts in roadways and shallow linear ponds. The cost of this method is the most expensive of the three methods; however, it produces the cleanest water.

### ***Purpose and Overview***

Presented in this appendix are technologies available to engineers, hydrologists, and construction personnel for the removal of suspended sediment and reduction of the associated turbidity in waters produced as a part of dewatering operations at construction sites in Florida. The technologies are divided into groups: Sediment Traps and Sediment Basins, Weir Tanks and Dewatering Tanks, Filters, and Chemical Treatment. The information provided for each group of technologies, as applied to dewatering operations, generally includes the following types of information:

- Description of the technology
- General application of the technology
- Limitations of the technology
- Considerations for implementation of the technology



- Inspection and maintenance needs
- Design considerations for the technology

Additional design specifications and implementation guidance for many of the presented technologies are provided in other sections of this manual (see the Table of Contents).

### ***Description***

Dewatering operations are practices that manage the discharge of turbidity when waters other than stormwater and accumulated runoff water must be removed from a work location so that construction work may be accomplished. These waters include, but are not limited to, groundwater, water from cofferdams, water diversions, and waters used during construction activities that must be removed from a work area.

### ***Application***

These practices are implemented for discharges of waters from construction sites. Practices identified in this section are also appropriate for implementation when managing the removal of accumulated rainfall excess or runoff from depressed areas at a construction site.

### ***Limitations***

- Site conditions will dictate design and use of dewatering operations.
- The controls discussed in this “best management practice” (BMP) address sediment only.
- The controls described below in this BMP only allow for minimal settling time for sediment particles. Use only when site conditions restrict the use of the other control methods.
- Dewatering operations require, and must comply with, applicable local and Florida Department of Environmental Protection (FDEP), and Water Management District (WMD) regulatory requirements. For discharges of produced ground water from a non-contaminated site activity a FDEP Generic Permit is required ([http://www.dep.state.fl.us/legal/rules/shared/62-621\(2\).doc](http://www.dep.state.fl.us/legal/rules/shared/62-621(2).doc)). For contaminated sites no Generic Permit is available and the FDEP should be contacted for applicable requirements (<http://www.dep.state.fl.us/legal/rules/rulelistnum.htm>). For WMD regulatory requirements contact the WMD with jurisdiction where the construction site is located.
- Avoid dewatering discharges, if possible, by using the water for dust control, infiltration, etc.
- Design of this BMP requires significant professional judgment and experience because of the many influencing environmental variables to consider, such as: pumping rate, depth and area of dewatering, depth to groundwater table, soil hydraulic conductivity, soil particle sizes, and many others.

### ***Implementation***

- Dewatering operations cannot be started without prior notice to and approval from FDEP and local water management districts. This includes runoff water that is co-mingled with groundwater or other water sources. Once the discharge is allowed, appropriate BMPs must be implemented to ensure the discharge complies with all permit and other regulatory requirements.
- FDEP may require a separate NPDES permit prior to the dewatering operation. These permits will have specific testing, monitoring, and discharge requirements and can take significant time to obtain.
- The flow chart shown in Figure AII-1 should be utilized to guide dewatering operations.
- Table AII-1 provides a comparison of the technologies in this appendix.
- Dewatering discharges must not cause erosion at the discharge point.

### ***Inspection and Maintenance***

- Inspect and verify that BMPs are in place prior to the commencement of activities. While activities associated with the BMP are under way, inspect daily during the rainy season and at least weekly in the non-rainy season to verify continued BMP implementation.
- Inspect BMPs subject to dewatering until all dewatering operations are completed.
- Specific maintenance requirements for each BMP are included with the description of each.
- Sediment removed during the maintenance of a dewatering device may be either spread onsite and stabilized, or disposed of at a disposal site as approved by the owner.
- Sediment that is co-mingled with other pollutants must be disposed of in accordance with all applicable laws and regulations and as approved by the owner.

A variety of methods can be used to treat turbid water during dewatering operations. A number of technologies and approaches are presented below and provide options to achieve sediment removal. The size of particles present in the sediment and the receiving water body capacity are key considerations for selecting sediment treatment option(s); in some cases, the use of multiple devices in a “treatment train” may be appropriate.

## Control Technologies

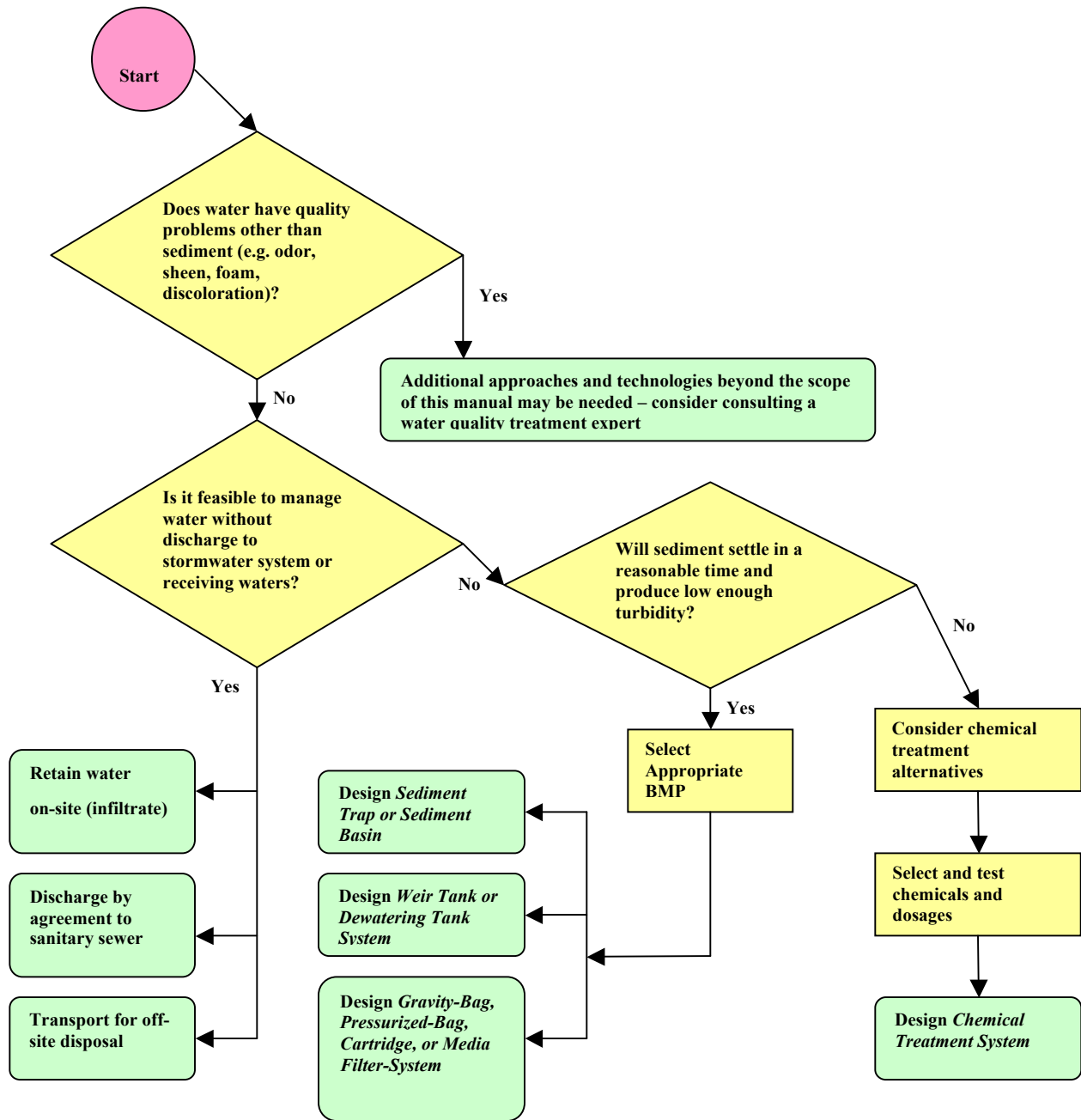

Figure AII-1. Dewatering Operations Flow Chart

**Table AII-1.** Comparison of dewatering technologies.

<b>Treatment Technology Group</b>	<b>Treatment Technology</b>	<b>Pollutant Treated</b>	<b>Design Flow (gpm)</b>	<b>Footprint (sq. ft.)</b>
<i>Sediment Traps &amp; Sediment Basins</i>	<i>Sediment Traps</i>	<i>Sediment</i>	<i>25 to 500</i>	<i>Varies</i>
	<i>Sediment Basins</i>	<i>Sediment</i>	<i>25 to 500</i>	<i>Varies</i>
<i>Weir Tanks &amp; Dewatering Tanks</i>	<i>Weir Tanks</i>	<i>Sediment, Metals, Oil &amp; Grease</i>	<i>60 to 100</i>	<i>1,800</i>
	<i>Dewatering Tanks</i>	<i>Sediment, Metals, Oil &amp; Grease</i>	<i>Varies</i>	<i>1,200 to 1,500</i>
<i>Filters</i>	<i>Gravity Bag Filter</i>	<i>Sediment and Metals</i>	<i>300 to 800</i>	<i>100 to 400</i>
	<i>Sand Media Filter</i>	<i>Sediment, Metals, BOD</i>	<i>80 to 1,000</i>	<i>17 to 450</i>
	<i>Pressurized Bag and Cartridge Filter</i>	<i>Sediment, Metals, BOD, and Hydrocarbons</i>	<i>50 to 1,000</i>	<i>200 to 320</i>
<i>Chemical Treatment</i>	<i>Continuous Chemical Treatment</i>	<i>Sediment</i>	<i>Varies</i>	<i>Varies</i>
	<i>Batch Chemical Treatment</i>	<i>Sediment</i>	<i>Varies</i>	<i>Varies</i>

Source: Caltrans, Management of Construction Site Dewatering Operations, 2006.

## ***Sediment Traps and Sediment Basins***

### **Sediment Trap**

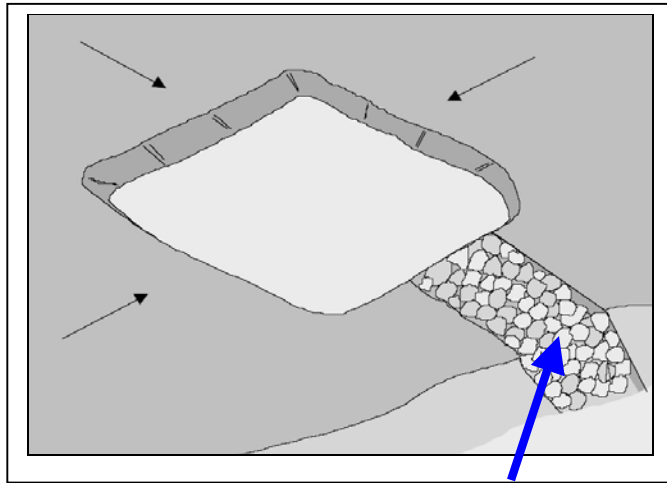

Turbidity Sampling Point Sediment Trap



Sediment Trap (Source: <http://www.mnerosion.org>)

-- A sediment trap is a temporary basin formed by excavation and/or construction of an earthen embankment or low drainage area to detain sediment-laden runoff and allow sediment to settle out before discharging. Sediment traps are generally smaller than sediment basins. --

#### **What is its Purpose?**

- Effective for the removal of large and medium sized particles (sand and gravel) and some metals that settle out with the sediment.

#### **Where and How is it commonly Used?**

- The location of the inflow pipe should be located as far away from the outfall to increase the residence time in the trap and allow more time for sediments to settle out.
- Use rock or vegetation to protect the trap outlets against erosion.
- If off-site discharge is proposed, the turbidity sampling location should be at the discharge point of the sediment trap.

#### **What Maintenance Activities can be Expected?**

- Daily inspections of sediment trap embankments and discharge point should be performed to prevent washout, scouring, and embankment blowouts.
- Removal of sediment is required when the storage volume is reduced by one-half.

## Sediment Basin

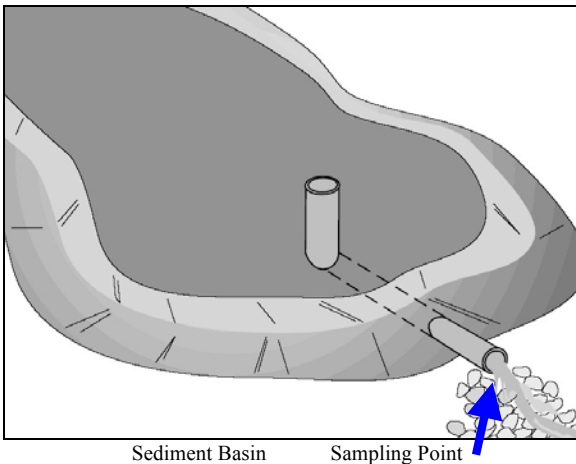

-- A sediment basin is a temporary basin with a controlled release structure that is formed by excavation or construction of an embankment to detain sediment-laden runoff and allow sediment to settle out before discharging. Sediment basins are generally larger than sediment traps. --

### **What is its Purpose?**

- Effective for the settling of sediments such as sand, silt, and some metals that settle out with the sediment.

### **Where and How is it commonly Used?**

- Excavation and construction of related facilities is required.
- Temporary sediment basins must be fenced if safety is a concern.
- Outlet protection is required to prevent erosion at the outfall location.
- If off-site discharge is proposed, the turbidity sampling location should be at the discharge point of the basin.

### **What Maintenance Activities can be Expected?**

- Daily inspections of sediment basin embankments and discharge point should be performed to prevent washout, scouring, and embankment blow-outs.
- Removal of sediment is required when the storage volume is reduced by one-half.

## ***Filters***

### **Gravity Bag Filter**

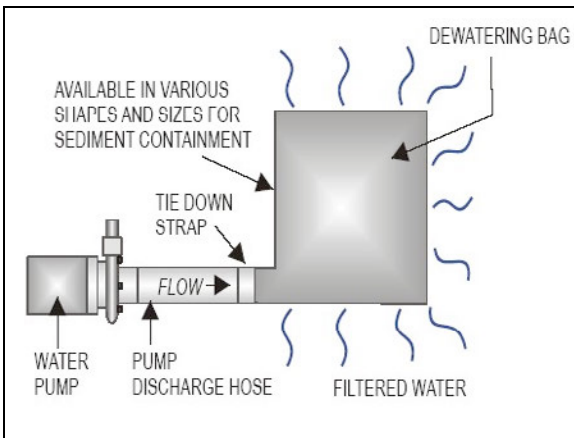

Gravity Bag Filter



Gravity Bag Filter (Source: <http://www.spillcontainment.com>)

-- A gravity bag filter, also referred to as a dewatering bag, is a square or rectangular bag made of non-woven geotextile fabric that collects sand, silt, and fines. --

#### **What is its Purpose?**

- Effective for the removal of sediments (gravel, sand, and silt). Some metals are removed with the sediment.

#### **Where and How is it commonly Used?**

- Water is pumped into one side of the bag and seeps through the bottom and sides of the bag.
- A secondary barrier, such as a rock filter bed or geo barrier, is placed beneath and beyond the edges of the bag to capture sediments that escape the bag.

#### **What Maintenance Activities can be Expected?**

- Inspection of the flow conditions, bag condition, bag capacity, and the secondary barrier is required.
- Replace the bag when it no longer filters sediment or passes water at a reasonable rate.
- The bag is disposed of offsite.

#### **Where and When Should it not be Used?**

- Based on the velocity of water passing through the bag, the seams of the bag may fail.

## ***Weir Tanks and Dewatering Tanks***

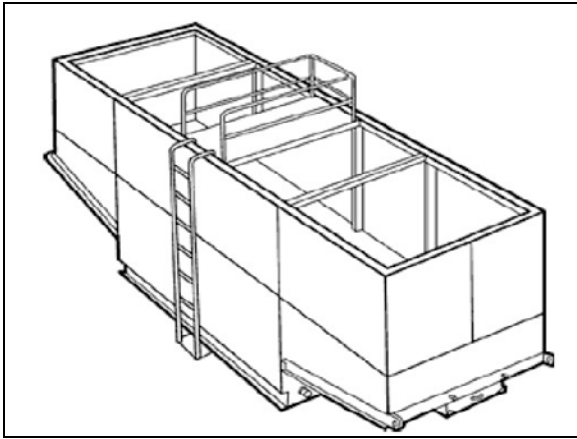

Weir Tank (Baker Tank) (Source: <http://www.dot.ca.gov>)



Dewatering Tank (Source: <http://www.dot.ca.gov>)

### Weir Tanks

-- A weir tank separates water and waste by using weirs. The configuration of the weirs (over and under weirs) maximizes the residence time in the tank and determines the waste to be removed from the water, such as oil, grease, and sediments. --

#### **What is its Purpose?**

- The tank removes trash, some settleable solids (gravel, sand, and silt), some visible oil and grease, and some metals (removed with sediment). To achieve high levels of flow, multiple tanks can be used in parallel. If additional treatment is desired, the tanks can be placed in series or as pre-treatment for other methods.

#### **Where and How is it commonly Used?**

- Tanks are delivered to the site by the vendor, who can provide assistance with set-up and operation.
- Tank size will depend on flow volume, constituents of concern, and residency period required. Vendors should be consulted to appropriately size tank.

#### **What Maintenance Activities can be Expected?**

- Periodic cleaning is required based on visual inspection or reduced flow.
- Oil and grease disposal must be by licensed waste disposal company.

### Dewatering Tanks

-- A dewatering tank removes debris and sediment. Flow enters the tank through the top, passes through a fabric filter, and is discharged through the bottom of the tank. The filter separates the solids from the liquids. --

#### **What is its Purpose?**

- The tank removes trash, gravel, sand, and silt, some visible oil and grease, and some metals (removed with sediment). To achieve high levels of flow, multiple tanks can be used in parallel. If additional treatment is desired, the tanks can be placed in series or as pretreatment for other methods.

#### **Where and How is it commonly Used?**

- Tanks are delivered to the site by the vendor, who can provide assistance with set-up and operation.
- Tank size will depend on flow volume, constituents of concern, and residency period required. Vendors should be consulted to appropriately size tank.



### What Maintenance Activities can be Expected?

- Periodic cleaning is required based on visual inspection or reduced flow.
- Oil and grease disposal must be by licensed waste disposal company.

The following methods are generally used when land is a limiting factor. These are generally very costly, so the Designer is encouraged to seek out the most cost effective method.

### Sand Media Filter



Sand Media Particulate Filter

(Source: <http://www.dot.ca.gov>)



Sand Media Particulate Filter

(Source: <http://www.spillcontainment.com>)

-- Water is treated by passing it through canisters filled with sand media. Generally, sand filters provide a final level of treatment. They are often used as a secondary or higher level of treatment after a significant amount of sediment and other pollutants have been removed using other methods. --

### What is its Purpose?

- Effective for the removal of trash, gravel, sand, and silt and some metals, as well as the reduction of biochemical oxygen demand (BOD) and turbidity.
- Sand filters can be used for stand-alone treatment or in conjunction with bag and cartridge filtration if further treatment is required.
- Sand filters can also be used to provide additional treatment to water treated by settling or basic filtration.

### Where and How is it commonly Used?

- The filters require delivery to the site and initial set up. The vendor can provide assistance with installation and operation.

### What Maintenance Activities can be Expected?

- The filters require regular service to monitor and maintain the level of the sand media. If subjected to high loading rates, filters can plug quickly.
- Vendors generally provide data on maximum head loss through the filter. The filter should be monitored daily while in use, and cleaned when head loss reaches target levels.
- If cleaned by backwashing, the backwash water may need to be hauled away for disposal, or returned to the upper end of the treatment train for another pass through the series of dewatering BMPs.

## Pressurized Bag and Cartridge Filters



Pressurized Bag Filter

(Source: <http://www.dot.ca.gov>)



Cartridge Filter

(Source: <http://www.dot.ca.gov>)

-- A pressurized bag filter is a unit composed of single filter bags made from polyester felt material. The water filters through the unit and is discharged through a header. Vendors provide bag filters in a variety of configurations. Some units include a combination of bag filters and cartridge filters for enhanced contaminant removal. --

-- Cartridge filters provide a high degree of pollutant removal by utilizing a number of individual cartridges as part of a larger filtering unit. They are often used as a secondary or higher (polishing) level of treatment after a significant amount of sediment and other pollutants are removed. Units come with various cartridge configurations (for use in series with bag filters) or with a larger single cartridge filtration unit (with multiple filters within). --

### What is its Purpose?

- Effective for the removal of sediment (sand, silt, and some clays) and some metals, as well as the reduction of BOD, turbidity, and hydrocarbons. Oil absorbent bags are available for hydrocarbon removal.
- Filters can be used to provide secondary treatment to water treated via settling or basic filtration.
- Hydrocarbons can often be removed with special resin cartridges.

### Where and How is it commonly Used?

- The filters require delivery to the site and initial set up. The vendor can provide assistance with installation and operation.

### What Maintenance Activities can be Expected?

- The filter bags require replacement when the pressure differential equals or exceeds the manufacturer's recommendation.
- The cartridges require replacement when the pressure differential equals or exceeds the manufacturer's recommendation.

## Chemical Treatment

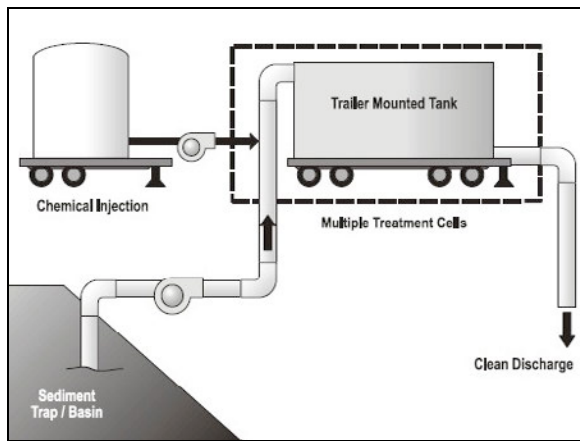

From a holding area using Alum

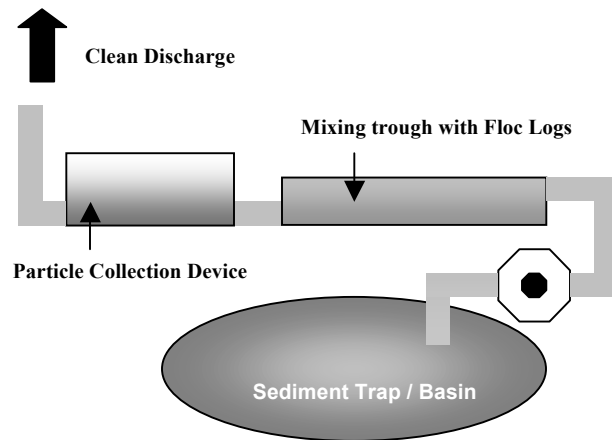

Using in-line mixing with a Flocc Log

-- Chemical treatment includes the application of carefully selected chemicals such as polymers (e.g. PAM), alum, and other flocculants to waters to aid in the reduction of turbidity by more efficient removal of fine suspended sediment. – also see Appendix III for additional chemical applications.

### What is its Purpose?

- Appropriate chemical treatment can reliably provide exceptional reductions of turbidity and associated pollutants and should be considered where turbid discharges to sensitive waters cannot be avoided using other available BMPs.

### Where and How is it commonly Used?

- The use of chemical treatment must have the pre-approval of FDEP
- Sediment basins or trailer-mounted unit can be designed for chemical application
- Treatment systems can be designed to be flow-through continuous or batch-treatment systems
- May require large area
- Limited discharge rates depending on receiving water body
- Operation and maintenance requirements need to be considered in the design
- Requires monitoring for non-visible pollutants

### What Maintenance Activities can be Expected?

- Turbidity is difficult to control if fine particles are suspended in dewatering waters from a construction site. Sedimentation ponds are effective at removing larger particulate matter by gravity settling, but are ineffective at removing smaller particulates such as clay and fine silt. Sediment ponds are typically designed to remove sediment no smaller than medium silt (0.02 mm). Chemical treatment may be used to reduce the turbidity of waters to be discharged. Turbidities need to be reduced to levels less than 29 NTUs above the background.
- Chemically treated waters to be discharged from construction sites must be non-toxic to aquatic organisms. The following protocol should be used to evaluate chemicals proposed for use in treatment at construction sites. Authorization to use a chemical in the field based on this protocol does not relieve the applicant from responsibility for meeting all discharge and receiving water criteria applicable to a site.
  - Treatment chemicals must be approved by FDEP and EPA for potable water use.

- Prior to authorization for field use, laboratory batch tests should be conducted to demonstrate that turbidity reduction necessary to meet the receiving water criteria could be achieved. Test conditions, including but not limited to raw water quality and laboratory test procedures should be indicative of field conditions. Although these small-scale tests cannot be expected to reproduce performance under field conditions, they are indicative of treatment capability. Testing should use water from the construction site at which the treatment chemical is proposed for use.
- Prior to authorization for field use, the chemical treatment should be tested for aquatic toxicity using a “worst case scenario” of whole product release. Whole Effluent Toxicity testing and limits (ASTM WET test procedures), should be used.
- The proposed maximum dosage should be at least a factor of five lower than the No Observed Effects Concentration (NOEC).
- The approval of a proposed treatment chemical should be conditional, subject to full-scale bioassay monitoring of treated waters at the construction site where the proposed treatment chemical is to be used.
- Treatment chemicals that have already passed the above testing protocol do not need to be reevaluated. Contact the FDEP for a list of treatment chemicals that may be approved for use.

#### **How Should it be Designed?**

- The design and operation of a chemical treatment system should take into consideration the factors that determine optimum, cost-effective performance. It may not be possible to fully incorporate all of the classic concepts into the design because of practical limitations at construction sites. Nonetheless, it is important to recognize the following:
  - The **right** chemical must be used at the **right** dosage. A dosage that is either too low or too high is not likely to produce the lowest turbidity. There is usually an optimum dosage rate.
  - The flocculant must be mixed rapidly into the water to insure proper dispersion.
  - Sufficient flocculation might occur in the pipe leading from the point of chemical addition to the settling or sediment basin.
  - Chemical Treatment Systems require mixing of the chemical and the turbid water to cause flocculation to occur. The size and volume of the treatment system may be restricted to provide adequate mixing.
  - Care must be taken in the design of the withdrawal system to minimize outflow velocities and to prevent floc discharge. If possible, the discharge should be directed through a physical filter such as vegetated swale that would catch any unintended floc discharge.
  - A pH-adjusting chemical should be added into the sediment basin, if needed, to control *pH*.

#### CTS-1 Continuous Treatment

##### **What is its Purpose?**

- Chemical Treatment Systems can be designed as flow-through continuous treatment systems.
- These systems consist of the collection system, a chemical mixing system (where the chemical is mixed with the turbid water), sediment collection device, and interconnecting conveyances.
- It may include a pump or pumps, to help convey the turbid water through the treatment system; however, these are not always required.
- Primary sediment basins, or grit pits, may be required if the water to be treated has a high percentage of suspended solids to prevent sediment from burying the treatment system and reducing its efficiency.

### **Where and How is it commonly Used?**

- The size of the continuous treatment system has to allow for continuous mixing for the length of time required to complete the CTS reaction at the flow rate expected through the system.
- The combination of any holding areas and treatment system capacity should be large enough to treat the volume of water anticipated.
- The TSS of the water running through the treatment system is not to exceed 4% suspended solids or a turbidity reading greater than 40,000 *NTU*.
- Primary settling should be encouraged in a sediment basin or sediment trap if the suspended solids load is above this level.
- On sites where the suspended solids load heading to the treatment system is below this level sediment basins or sediment traps are not required for normal flow conditions, but some sort of particle collection device should be installed to prevent sediment deposition in the treatment system due to heavy rain events.
- The following discharge flow rate limits apply absent any local requirements:
  - If the discharge is direct or indirect to a stream, the discharge flow rate should not exceed 50 percent of the peak flow rate for all events between the 2-year and the 10-year, 24-hour event.
  - If discharge is occurring during a storm event equal to or greater than the 10-year storm the allowable discharge rate is the peak flow rate of the 10-year, 24-hour event.
  - Discharge to a stream should not increase the stream flow rate by more than 10 percent.
  - If the discharge is directly to a lake or major receiving water there is no discharge flow limit.
  - If the discharge is to a municipal storm drainage system, the allowable discharge rate may be limited by the capacity of the public system. It may be necessary to clean the municipal storm drainage system prior to the start of the discharge to prevent scouring solids from the drainage system.

### **What Maintenance Activities can be expected?**

- Inspect the flow-through treatment system at least daily and after rain events of ½ inch or greater, taking care to ensure the chemical treatment products are in place, moist, and have not been buried by sediment.
- Inspect, repair, and clean out the sediment collection devices as needed to keep the system working at peak efficiency.
- Compliance Monitoring:
  - *pH* and turbidity of the treated water
  - *pH* and turbidity of the receiving water
- Discharge Compliance:
  - Treated water must be sampled and tested for compliance with *pH* and turbidity limits at least two times per day. These limits may be established by the water quality standards or a site-specific discharge permit.
  - Sampling and testing for other pollutants may also be necessary at some sites.
  - Turbidity must be within 29 *NTU* of the background turbidity. Background is measured in the receiving water, upstream from the treatment process discharge point.
  - The *pH* must be within the range of 6.5 to 8.5 standard units and not cause a change in the *pH* of the receiving water of more than 0.2 standard units.
  - It is often possible to discharge treated water that has a lower turbidity than the receiving water and that matches the *pH*.
  - Treated water samples and measurements should be taken from the point of discharge.
  - Compliance with the water quality standards is determined in the receiving water.

- Sediment Removal and Disposal:
  - Flocculated sediment should be removed from the sediment collection devices as necessary. Treated sediment can be disposed of in a landfill or can be used as a topsoil amendment elsewhere on the site to help prevent erosion and enhance vegetation establishment.
  - Flocculated sediment should never be used as structural fill material.

### CTS-2 Batch Treatment

#### **What is its Purpose?**

- Chemical treatment systems can be designed as batch treatment systems using either ponds or portable trailer-mounted tanks.
- This chemical treatment system consists of the collection system, a sediment basin or sediment trap, pumps, a chemical feed system, treatment cells, and interconnecting piping.

#### **Where and How is it commonly Used?**

- The treatment system should use a minimum of two lined treatment cells. Multiple treatment cells allow for clarification of treated water while other cells are being filled or emptied.
- Treatment cells may be basins, traps or tanks. Portable tanks may also be suitable for some sites.
- The following equipment should be located in an operation shed:
  - The chemical injector
  - Secondary contaminant for acid, caustic, buffering compound, and treatment chemical
  - Emergency shower and eyewash
  - Monitoring equipment which consists of a *pH* meter and a turbidimeter
- Sizing Criteria:
  - The combination of the sediment basin or other holding area and treatment capacity should be large enough to treat the volume of water anticipated.
  - Bypass should be provided around the chemical treatment system to accommodate extreme storm events.
  - Primary settling should be encouraged in the sediment basin/storage pond. A “fore bay” with access for maintenance may be beneficial.
  - There are two opposing considerations in sizing the treatment cells. A larger cell is able to treat a larger volume of water each time a batch is processed. However, the larger the cell the longer the time required to empty the cell. A larger cell may also be less effective at flocculation and therefore require a longer settling time.
  - The simplest approach to sizing the treatment cell is to multiply the allowable discharge flow rate times the desired drawdown time. A 4-hour drawdown time allows one batch per cell per 8-hour work period, given 1 hour of flocculation followed by 2 hours of settling.
  - The permissible discharge rate governed by potential downstream effect can be used to calculate the recommended size of the treatment cells.

- The following discharge flow rate limits apply absent any local requirements:
  - If the discharge is direct or indirect to a stream, the discharge flow rate should not exceed 50 percent of the peak flow rate for all events between the 2-year and the 10-year, 24-hour event.
  - If discharge is occurring during a storm event equal to or greater than the 10-year storm the allowable discharge rate is limited to the peak flow rate of the 10-year, 24-hour event.
  - Discharge to a stream should not increase the stream flow rate by more than 10 %.
  - If the discharge is directly to a lake or major receiving water there is no discharge flow limit.
  - If the discharge is to a municipal storm drainage system, the allowable discharge rate may be limited by the capacity of the public system. It may be necessary to clean the municipal storm drainage system prior to the start of the discharge to prevent scouring solids from the drainage system.

### What Maintenance Activities can be Expected?

- Chemical treatment systems must be operated and maintained by individuals with expertise in their use.
- Chemical treatment systems should be monitored continuously while in use.
- Test results should be recorded on a daily log kept on site.
- Operational Monitoring:
  - *pH*, conductivity (as a surrogate for alkalinity), turbidity, and temperature of the untreated water
  - Total volume treated and discharged
  - Discharge time and flow rate
  - Type and amount of chemical used for *pH* adjustment
  - Amount of polymer, alum, or other flocculant used for treatment
  - Settling time
- Compliance Monitoring:
  - *pH* and turbidity of the treated water
  - *pH* and turbidity of the receiving water
- Bio-monitoring:
  - Treated water should be tested for acute (lethal) toxicity. Bioassays should be conducted by a laboratory approved by the State of Florida. ***The performance standard for acute toxicity has no statistically significant difference in survival between the control and 100 percent chemically treated water.*** Acute toxicity tests should be conducted with the following species and protocols (or others approved by the State):
    - Fin Fish; fathead minnow, *Pimephales promelas* or rainbow trout, *Oncorhynchus mykiss*.
    - Water fleas; *Ceriodaphnia dubia*, *Daphnia pulex*, or *Daphnia magna*
    - All toxicity tests should meet quality assurance criteria and test conditions in the most recent version of the EPA test method (EPA-821-R-02-012). Bioassays should be performed on the first five batches and on every tenth batch thereafter or as otherwise approved by the State. Failure to meet the performance standard should be immediately reported to the State.
- Discharge Compliance:
  - ***Prior to discharge, each batch of treated water must be sampled and tested for compliance with pH and turbidity limits.*** These limits may be established by the water quality standards or a site-specific discharge permit. Sampling and testing for other pollutants may also be necessary at some sites. Turbidity must be within 29 NTUs of the background turbidity.

Background is measured in the receiving water, upstream from the treatment process discharge point. *pH* must be within the range of 6.5 to 8.5 standard units and not cause a change in the pH of the receiving water of more than 0.2 standard units. It is often possible to discharge treated water that has a lower turbidity than the receiving water and that matches the *pH*. Treated water samples and measurements should be taken from the discharge pipe or another location representative of the nature of the treated water discharge. Samples used for determining compliance with the water quality standards in the receiving water should not be taken from the treatment pond to decanting. Compliance with the water quality standards is determined in the receiving water.

- Operator Training:
  - Each contractor who intends to use chemical treatment should be trained by an experienced contractor on an active site for at least 40 hours.
- Sediment Removal and Disposal:
  - Sediment should be removed from the storage or treatment cells as necessary. Sediment remaining in the cells between batches may enhance the settling process and reduce the required chemical dosage.



## **REFERENCES**

1. California Stormwater BMP Handbook 1 of 11 (Construction), 2003
2. UltraTech International, Inc., Compliance Products for Stormwater Management, (<http://www.spillcontainment.com>), 2006.
3. Minnesota Erosion Control Association, (<http://www.mnerosion.org>), 2006.
4. Caltrans, Management of Construction Site Dewatering Operations, (<http://www.dot.ca.gov/hq/construc/stormwater/dewateringclass.pdf>), 2006.

This page intentionally left blank

**APPENDIX III**  
**POLYMERS AND ALUM**

## INTRODUCTION

### *Overview of Polymers and Alum*

On construction projects, water can be turbid and some of the turbidity cannot be removed by standard practices. Polymers and alum can be used to reduce turbidity and other pollutants. Water can be treated to remove turbidity, and other water quality indicators, such as, color and bacteria. Early research into filtration made it apparent that it alone was not enough to produce clear water. In fact, experience has demonstrated that direct filtration is largely ineffective in removing bacteria, viruses, soil particles and color. The soil particles, bacteria and viruses all contribute to the turbidity of the water.

Coagulation is related to the removal of colloidal particles and is defined as the process that causes the colloids to approach and adhere to each other to form larger particles, or flocs. Coagulation and subsequent flocculation turns the smaller particles of turbidity, color and bacteria into larger flocs, either as precipitates or suspended particles. These flocs can then be readily removed.

During coagulation a positive ion is added to water to reduce the surface charge to the point where the particles are not repelled from each other. A coagulant is the chemical substance that is introduced into the water to accomplish this. Anionic polymers can act as coagulants by “bridging” cationic molecules ( $\text{Ca}^{++}$ ), this mechanism allows the anionic polymers to perform as a coagulant without the aquatic toxicity potential associated with industrial cationic coagulants. There are three key properties of a coagulant:

- a. Cations – these are most effective at neutralizing the net negative charge in natural water. (Cationic polymers have high toxicity potentials to aquatic organisms.)
- b. Nontoxic – this is needed to produce safe water.
- c. Insoluble in neutral pH range – the coagulant must precipitate out of solution so that high concentrations of the ion are not left in the water. Such precipitation assists in the colloidal removal process.

Examples of coagulants and flocculants are Polyacrylamide (PAM and PAM blends), Dual-polymer Systems, Aluminum ( $\text{Al}^{3+}$ ) in the form of dry or liquid Alum, and ferric iron ( $\text{Fe}^{3+}$ ) in the form of sulfate salt or chloride salt. Since Polyacrylamides are used in erosion and sediment control more than other coagulants, it will be discussed first, followed by the use of alum and other chemical coagulant forms.

### *Purpose and Overview*

This appendix presents technologies available to engineers, hydrologists, and construction personnel for the use of polymers, polymer blends and alum in erosion and sedimentation control techniques in Florida. The appendix is divided into three sections, PAMs, Alum and Dual-Polymer systems. Temporary and permanent control technologies are presented for each section. The information provided for each technology includes:

- A description of the technology
- The general purpose(s) of the technology
- Considerations for implementation of the technology
- When the technology should be implemented
- Where and when the technology should not be used
- Inspection and maintenance needs

Additional specifications and steps for implementation of many of the technologies are provided in sections I - V.

**POLYACRYLAMIDES (PAM and PAM Blends)**

### Polyacrylamides (PAM and PAM blends)

#### **What is its Purpose?**

- To reduce soil erosion through soil binding.
- As a water treatment additive to remove suspended particles from runoff.
- To provide an appropriate medium for the growth of vegetation for further stabilization.
- Increases infiltration through increasing particle size and pore spaces.

#### **Where and How is it Commonly Used?**

- PAM is suitable for use on disturbed soil areas that discharge to a sediment trap or sediment basin.
- PAM is typically used in conjunction with other BMPs to increase their performance.
- It can be applied to the following areas – rough graded soils, final graded soils before application of stabilization, temporary haul roads prior to placing crushed rock surfacing, compacted soils road base, construction staging and materials storage areas, soil stockpiles and areas to be mulched.
- PAM may be applied in dissolved form with water, or it may be applied in dry, granular, or powdered form. It may also be placed in the form of floc logs for passive dosing and for water quality improvement.
- Higher concentrations of PAM do not provide any additional effectiveness.

#### **When Should it be Installed?**

- While construction activities are occurring.
- PAM must be reapplied on actively worked areas if PAM is to remain effective. Reapplication is not required unless PAM treated soil is disturbed or unless turbidity levels show the need. Undisturbed soils treated with PAM may require reapplication after 2 months.

#### **Where and When Should it not be Installed?**

- If there is a potential of equipment clogging.
- Where it violates toxicity requirements.

#### **What Needs to be Inspected?**

- Visual observation of floc particles in the discharge.

#### **What Maintenance Activities can be expected?**

- Reapply PAM to disturbed or tilled areas that require continued erosion control.
- Rinse all PAM mixing and application equipment thoroughly with water to avoid formation of PAM residues.
- Downstream deposition from the use of PAM may require periodic sediment removal to maintain normal functions.

## NOTES

### 1. Introduction

PAM is a water-soluble anionic polyacrylamide product used to minimize soil erosion caused by water and wind. It can also be used to decrease loss by binding soil particles, especially clays, which will hold them on site. In addition, these types of materials may also be used as a water treatment additive to remove suspended particles from runoff. Polyacrylamides can be used in several forms:

- Powder
- Powder added to water (wet, as a stock solution)
- Emulsion
- Gel Blocks or Bricks

*Flocculation with polymers has been extensively used within the mining industry (Carter & Schiener, 1991) and recently has begun expanding into the erosion and sediment control industries. Greater scrutiny of NPDES phase II requirements has increased the demand for higher water quality discharges within both of these industries. Conventional mechanical runoff BMPs have shown limited or non-compliant capability to remove or reduce dissolved nutrients, colloidal clay and metal contamination from construction site discharges. The colloidal constituents within runoff and construction site discharges have driven the Designer to expand the scope for the use of chemical treatment systems.*

Engineering designs using Stokes Law have adequately addressed the heavier particulate but continue to fail in the removal or adequate reduction of the colloidal fractions and metals (Erwin, 1978).

Environmentally safe polymer and polymer-coagulant combinations have shown significant reductions of metals (Iwinski, 1995; 2006), nutrient (Chastain, et al., 2004) and colloidal clays (Sojka, et al., 2003). A large variety of pipe mixing systems are now in use to employ these new polymer mixes into the contaminated water streams enabling engineers and construction groups to maintain compliant water quality discharges. Gowdy, et al., (2006) presented a paper at the REMTECH conference on cost-effective and efficient methodologies utilizing water-soluble PAM to routinely reduce erosion and runoff turbidity by over 95%. Resultant soil particles are flocculated, agglomerated and chelated in-situ, with significantly reduced suspended solids, metals, TMDLs and NTU values of runoff waters entering riparian water bodies.

Anionic polyacrylamide type polymers (PAMs) have become the most common materials used for water clarification and erosion control on construction sites and in sedimentation treatment systems. PAM-type polymers and blends have become highly specific for each application due to the complexity of clay variants and colloidal elements within the contaminated waters to be treated. This is not a new concept and has been widely used in other industries including erosion control in which specific polymer types are used to achieve best performance (Green and Stott, 1999). PAMs have recently been used for treatment of lagoon effluent from livestock operations (Flanagan and Canady, 2006). They studied the effect of using anionic PAM in the wastewater irrigation on reducing the losses of soluble and total nutrients (nitrogen and phosphorus) from soil. The study found that the PAM addition was effective in reducing losses of soluble ammonium nitrogen (up to 92%), soluble phosphorus (up to 71%), and also reduced total (sediment-bound) nutrient losses.

The most common methods previously used are the application of a spray or dry powder application to a disturbed soil surface to reduce the solubility of the clays into the runoff water at the source, although this has limited effect on water that has escaped from areas outside the treated soils. This method may

be the most effective in reducing the bulk of clayey particulate (Sojka, et al., 2003) although most PAMs that are used today are marketed as a “one PAM fits all” method. This method works poorly as PAMs must be tested for each clay type found in the soil, similar to procedures used in conventional water treatment industries. Improperly applied or incorrect PAMs will detach and escape from the soil surface and move into the receiving waters sometimes causing greater water quality issues than that of elevated turbidity of the runoff water alone.

Cationic PAM and chitosan have a very limited use due to the highly toxic potential to aquatic organisms. These materials must be used under highly controlled conditions and never allowed to discharge to riparian water systems without significant filtration. Cationic PAMs or biopolymers derived from chitin have shown significant toxicity issues to aquatic organisms (Orme and Kegley, 2004) and their use is commonly prohibited for most in-situ applications. Increased scrutiny of cationic polymers and chitosan is becoming more common as engineers and contractors become aware of the potential risks, technical guidelines and law. (Alabama Handbook, 2003; Georgia Soil Water Conservation Commission, 2000; Virginia Erosion & Sediment Control Handbook n.d.)

When PAM is used on construction sites in the southeast it is typically applied with temporary seeding and or mulching on areas where the timely establishment of temporary erosion control is so critical that seeding and mulching need additional reinforcement. It may be used alone on sites where no disturbances will occur until site work is continued and channel erosion is not a significant potential problem. Permanent grassing applications can be better established using PAM as a tackifier and soil conditioner.

PAMs are manufactured in various forms to be used on specific soil types, and are generally applied at a rate of up to 50 pounds/acre for dry products and 2 ½ gallons/acre of emulsion-liquid products. Using the wrong form of a PAM on a soil will result in some degree of performance failure, and increase the potential for this material to enter surface waters. PAM used alone may not reduce NTU values significantly, resulting in noncompliant water quality discharges or poor soil binding conditions. Site specific soil-PAM testing must be performed. Exceeding the maximum application rates for this product does not increase the effectiveness of the product. Block or Log forms of PAM and PAM blends are manufactured for specific use in drainage waterways to remove suspended particulates from runoff.

According to Green and Scott (2001), PAM is versatile and effective in reducing runoff, erosion and soil sealing. It is also economical compared to other methods such as straw mulch product.

## **2. When to Use**

PAM is suitable for use on disturbed soil areas that discharge to a sediment trap or sediment basin. PAM is typically used in conjunction with other BMPs to increase their performance.

According to California Stormwater BMP Handbook (2003), PAM can be applied to the following areas:

- a. Rough graded soils that will be inactive for a period of time
- b. Final graded soils before application of final stabilization (eg. paving, planting, mulching)
- c. Temporary haul roads prior to placement of crushed rock surfacing
- d. Compacted soil road base
- e. Construction staging, materials storage, and layout areas
- f. Soil stockpiles
- g. Areas that will be mulched

## **3. How to Apply**

Prior to the start of construction, the application area or flow rate must be identified and the selection of a polymer made. Any polymer or alum must meet toxicity tests. If spreading of a polymer is used, applications assume that uniform coverage is attained. The application should conform to the design and specifications provided in the plans.



### Site Preparation

Prepare site following the project design and specifications.

### PAM Application - Criteria for Land applied PAM Specifications

PAM shall be mixed and/or applied in accordance with all Occupational Safety and Health Administration (OSHA) Material Safety Data Sheet (MSDS) requirements and the manufacturer's recommendations for the specified use conforming to all federal, state and local laws, rules and regulations.

## **4. Type of Polymers**

The use of PAM logs or block formulations may be the most effective methods for colloidal clay, nutrient and metal treatment in flowing water due to the ability to add reactive chemicals that will act upon the desired target clay, nutrient or metal. Column studies using site specific PAM formulations for waste rock have shown removal rates of 99% zinc, 99% copper, 99% silver, 54% phosphorous and 71% manganese (Iwinski, Stein, and Condon, 1996). An added benefit of these formulations is the ability of the molecules to utilize lignin or chelate reaction with metals, nutrient and clays which further reduce solubility and enhance more rapid settling characteristics (Yoon, et al., 1994). Liquid injection and powder feeding systems are either quite costly or lack the ability to carry the required treatment additives significantly reducing their performance and requiring expensive filtration to remove chemical residues and fine contaminants.

Specific blended PAM logs or blocks may be constructed in various ways to allow varying degrees of dosage application. This allows for multiple passive types of applications and a large degree of versatility for construction sites, runoff water and metal contaminated water flows. The absence of toxicity of these materials to aquatic organisms (Applied Polymer Systems, 2003) has created a much more versatile application window allowing for direct discharge to riparian waterways and substantially reducing cost. Particulate that is formed from these types of applications may be captured onto organic fabric surfaces or settled using conventional ponds, baffle grids or constructed wetlands. (McLaughlin, Hayes, and Bartholomew, 2003) Pipe mixing systems have the ability to react the turbid water with the polymer mixes rather quickly and settling times of particulates once reacted with the blended PAM logs or blocks are greatly reduced. This feature can allow for much smaller pond sizes, which reduce the area footprint of the pond and overall cost. This has prompted engineers to utilize this concept into project designs where a conventional pond may not be used, due to available land size restrictions, or in cases where water quality issues may arise. This new capability has allowed higher density development and land use, which only a few years ago were not, considered due to high construction costs or environmental risk.

## **5. Choice of Polymers**

The term 'Polymer Clarifier' refers to a polyacrylamide (PAM) and PAM blend, inclusive of any additives, i.e., a whole product as delivered by a manufacturer rather than an ingredient within a product delivered by a manufacturer. Only Polymer Clarifiers meeting all of the following criteria may be used:

- a. The Polymer Clarifier must be anionic (negatively charged).
- b. Specifically, no cationic formulations of a Polymer Clarifier will be accepted. Cationic forms of PAM, polymers and chitosan have high levels of toxicity to aquatic organisms. Emulsions shall never be applied directly to runoff or riparian waters due to surfactant toxicity.
- c. The PAM or PAM blend must be certified for compliance with ANSI/NSF Standard 60, potable drinking water grade, indicating a maximum residual acrylamide monomer limit of 0.05%.
- d. The manufacturer must provide a toxicological report for the Polymer Clarifier, performed by a third-party, approved laboratory. The information within the report must be derived from whole-product testing, using one or all of the protocols listed below, as designated by the species selected by the appropriate regulatory authority. The report shall verify that the Polymer Clarifier

exhibits acceptable toxicity parameters set by all applicable standards:

- i. EPA-821-R-02-012 (acute testing);
  - ii. EPA-821-R-02-013 (chronic testing);
- e. The manufacturer must provide a test report indicating that the Polymer Clarifier, when tested with site-specific soils, demonstrates a lab performance level of at least 95% in reducing NTU or TSS levels. In Florida, the post-treated value of NTU must be less than 29.

## **6. Dosage Calculations**

- a) The dosage rates are described with each of the applications in Section 13 and are based on Florida soils. Polymer dosage rates will vary with site-specific applications along with water and soil requirements. Higher doses of certain polymer types or blends may result in extreme viscosity and may result in impaired applications when using spraying devices. The polymer enhancements within this document are systems or methods that have been used over five or more years across the United States and Canada. All of the contained BMPs are in use in Florida and have performed as described when installed correctly. The entire polymer enhanced BMPs within this document are actual excerpts from applications within the southeastern United States. Each of the contained BMPs or their combinations have been documented and monitored. Reported water quality data, university testing documentation or NPDES reported data was used to verify the effectiveness of these BMPs.
- b) Polymer logs that are assembled from multiple polyacrylamide polymers, stabilizers and dispersion chemicals will absorb water and swell by varying values in relation to water chemistry, temperature, flow rate and time of reaction. This condition prohibits or greatly restricts the ability to mass balance the dissolution rate of the polymer log for dosage calculation. To accurately ascertain the dosage rate of each log type a controlled flow device was assembled, as shown in Figure 1, where the only variable is solubility. A piped system was constructed using filtered water (5 micron), which created a sustained flow rate and allowed for swelling of the polymer log without flow variation. This allowed for periodic sampling in which TSS and TDS could be analyzed. A standard was taken and the test samples were obtained at 5-minute intervals with five samples each for the three different polymer log types.



Figure AIII-1: Polymer Log dosage sampling device.

Each of the three polymer log types was constructed to a standard mold so the surface area would be the same and used as a reference size for the dosage calculation. The calculations of surface area are shown in Table 1.

**Table 1:** Surface Area Calculations of Polymer Log

**Measured Parameters: 29 inches long with 2-inch diameter**

Total surface area of log:

$$SA_{\text{total}} = SA_{\text{ends}} + SA_{\text{face}} \cdot SA_{\text{total}} = 2\pi r^2 + 2\pi rh$$

$$SA_{\text{total}} = 2 \times (3.14) \times (1 \text{ inch})^2 + 2 \times (3.14) \times (1 \text{ inch}) \times (29 \text{ inch})$$

$$SA_{\text{total}} = (6.28 \text{ in}^2) + (182.12 \text{ in}^2) = SA_{\text{total}} = \mathbf{188.40 \text{ inches}^2}$$

The flow rate was recorded throughout the sampling to assure no variation of flow and the flow rates for each of the three logs then calculated, as shown in Table 2. An outside certified lab then performed the TSS and TDS analysis and this data was used to calculate the actual dosage of each polymer log type as listed in Table 3.

**Table 2:** Flow Rate calculations for each Polymer Log**703d Polymer Log**

Filled 5 gallon pail in

46.82 seconds, 45.78 seconds, 45.62 seconds

Average = 46.07 seconds

$$\frac{5}{46.07 \text{ sec}} \times \frac{60 \text{ seconds}}{1 \text{ minute}} = 6.51 \text{ gallons per minute (gpm)}$$

**703d#3 Polymer Log**

Filled 5 gallon pail in

45.62 seconds, 45.09 seconds, 44.92 seconds

Average = 45.21 seconds

$$\frac{5}{45.21 \text{ sec}} \times \frac{60 \text{ seconds}}{1 \text{ minute}} = 6.63 \text{ gallons per minute (gpm)}$$

**706b Polymer Log**

Filled 5 gallon pail in

46.07 seconds, 45.20 seconds, 45.33 seconds

Average = 45.53 seconds

$$\frac{5}{45.53 \text{ sec}} \times \frac{60 \text{ seconds}}{1 \text{ minute}} = 6.59 \text{ gallons per minute (gpm)}$$

**Table 3: Dosage Rate calculations**

	TDS	TSS		TDS	TSS
<b>Control</b>	33	BRL			
<b>703d #1</b>	32	BRL	Average:	45.2	BRL
<b>703d #2</b>	48	BRL			
<b>703d #3</b>	51	BRL	Total Average:	45.2	mg/L
<b>703d #4</b>	41	BRL	minus control:	<b>12.2</b>	<b>mg/L</b>
<b>703d #5</b>	54	BRL			
<b>703d#3 #1</b>	55	6	Average:	47.0	6.8
<b>703d#3 #2</b>	46	7			
<b>703d#3 #3</b>	38	8	Total Average:	53.8	mg/L
<b>703d#3 #4</b>	60	6	minus control:	<b>20.8</b>	<b>mg/L</b>
<b>703d#3 #5</b>	36	BRL			
<b>706b #1</b>	75	BRL	Average:	57.4	BRL
<b>706b #2</b>	57	BRL			
<b>706b #3</b>	55	BRL	Total Average:	57.4	mg/L
<b>706b #4</b>	45	BRL	minus control:	<b>24.4</b>	<b>mg/L</b>
<b>706b #5</b>	55	BRL			

## 7. Performance Based Index Testing (NTU)

All vendors and suppliers of PAM, PAM mix or blends shall supply written “site specific” testing results demonstrating a performance of 95% or greater reduction of *NTU* or *TSS* from runoff waters. Emulsion batches shall be mixed following recommendations of a testing laboratory that determines the proper product and rate to meet site requirements. Application method shall insure uniform coverage to the target area. **(Emulsions shall never be applied directly to runoff or riparian waters)**

Dry form (powder) may be applied by hand spreader or a mechanical spreader. Mixing with dry silica sand will aid in spreading. Pre-mixing of dry form PAM into fertilizer, seed or other soil amendments is allowed when specified in the design plan. Application method shall insure uniform coverage to the target area. Block or Log forms shall be applied following site testing results to assure proper placement and performance and shall meet or exceed state and federal water quality requirements.

### Example Field Project – Example of a Flow-through System

A local development project needing assistance for dewatering supplied the test ponds both having elevated *NTU* values due to colloidal clay content. A complete dewatering system was set up as shown in Figures 2 and 3, using the pipe mixer feeding to a jute lined ditch to collect the particulate from the mixer. *NTU* readings were taken in each pond before pumping and recorded as background. Samples were taken every 5 minutes from end of mixer and the end of jute field before discharge to the riparian stream; the data is presented in Table 4. The pond volumes treated were calculated using the pump flow per time from start to finish. Two pipe mixing systems were used connected in a series using a duplex system. The duplex system for this water chemistry required the first mixer to be loaded with 8 each 703d polymer logs and the second mixer to be filled with 706b polymer logs. Using the dosage value derived from the lab test based on surface area of the polymer log the dosage was then adjusted to the surface area of the polymer logs within the mixers. Using the dosage rates measured in the lab the total dosage for the system was estimated to be 217.6 mg/L



Figure AIII-2: The water was pumped out of the sediment pond.



Figure AIII-3: The water was pumped through the pipe mixers and down a jute lined ditch.

**Table AIII-4:** APS Pipe Mixer Field Test 4/6/06

Site: Holly Commons		Soil Type: Silty Clay		Date: 4/6/06			
Background: 400 NTU, 5.38 pH		Flow Rate: 133 GPM		Conditions: Clear, sunny			
	<b>End of Mixer filtered with coffee filter</b>				<b>End of Jute Field</b>		
	<b>Time</b>	<b>NTU</b>	<b>pH</b>	<b>NTU</b>	<b>pH</b>	<b>NTU</b>	<b>pH</b>
Initial	10:25	35	5.8	24	5.84		
5 min	10:30	22	5.42	19	5.45	17	5.47
10 min	10:35	25	5.5	17	5.55	18	5.48
15 min	10:40	24	5.66	17	5.58	19	5.6
20 min	10:45	24	5.63	16	5.66	16	5.63
25 min	10:50	23	5.65	16	5.65	19	5.63
30 min	10:55	23	5.63	14	5.66	20	5.67
35 min	11:00	22	5.73	15	5.7	19	5.72
40 min	11:05	23	5.7	13	5.75	19	5.76
45 min	11:10	24	5.72	14	5.75	21	5.74
50 min	11:15	25	5.73	14	5.74	17	5.73
55 min	11:20	25	5.72	14	5.75	18	5.76
1 hour	11:25	40	5.73	13	5.73	32	5.74
1h 5 min	11:30	31	5.75	14	5.71	16	5.71
1h 10 min	11:35	25	5.77	16	5.75	20	5.74
1h 15 min	11:40	23	5.79	15	5.75	20	5.78
1h 20 min	11:45	25	5.76	15	5.74	19	5.76
1h 25 min	11:50	24	5.74	16	5.75	19	5.77
1h 30 min	11:55	27	5.76	14	5.73	23	5.74
1h 35 min	12:00	25	5.84	15	5.8	20	5.83
1h 40 min	12:05	23	5.81	13	5.76	19	5.79
1h 45 min	12:10	22	5.8	14	5.78	18	5.81

## **8. Toxic Requirements and Index Testing**

All vendors and suppliers of PAM, PAM mix or blends shall present or supply a written toxicity report which verifies that the PAM, PAM mix or blend exhibits acceptable toxicity parameters which meet or exceed the requirements for the state and federal water quality standards.

Cationic forms of PAM are not allowed for use under this guideline due to their high levels of toxicity to aquatic organisms. Emulsions shall never be applied directly to runoff or riparian waters due to surfactant toxicity.

Toxicological tests for the PAM is to be conducted using one or all of the protocols listed below, as designated by the species selected by the appropriate regulatory authority. The report shall verify that the Polymer Clarifier exhibits acceptable toxicity parameters set by all applicable standards:

EPA-821-R-02-012 (acute testing for freshwater/marine organisms);

EPA-821-R02-013 (chronic testing for freshwater organisms);

## **9. Design Considerations**

A discussion of design considerations is included with each application of polymers and alum.

## **10. Limitations of Use**

Consult with a registered design professional for assistance if any of the following occur:

- Problems with application equipment clogging.
- PAM alone may not meet testing requirements for NTU reduction and soil stabilization. Site specific “blends” may be needed to meet these requirements.
- Application specifications for PAM cannot be met; alternatives may be required. Unapproved application techniques could lead to failure.
- Visible erosion occurs after application.

## **11. Inspection and Maintenance Requirements**

An operation and maintenance plan must be prepared for use by the operator responsible for PAM application. Plan items should include the following items.

- Reapply PAM to disturbed or tilled areas that require continued erosion control.
- Maintain equipment to provide uniform application rates.
- Rinse all PAM mixing and application equipment thoroughly with water to avoid formation of PAM residues and discharge rinse water to soil areas where PAM stabilization may be helpful.
- Downstream deposition from the use of PAM may require periodic sediment removal to maintain normal functions.

The California Stormwater BMP Handbook (2003) suggests the following steps for an effective inspection and maintenance plan:

- Inspect BMPs prior to forecast rain, daily during extended rain events, after rain events, weekly during the rainy season, and at two-week intervals during the non-rainy season.
- Areas where erosion is evident should be repaired and BMPs re-applied as soon as possible. Care should be exercised to minimize the damage to protected areas while making repairs, as any area damaged will require re-application of BMPs.
- PAM must be reapplied on actively worked areas before storm events or when disturbance ceases if



PAM is to remain effective.

- Reapplication is not required unless PAM treated soil is disturbed or unless turbidity levels show the need for an additional application.
- If PAM treated soil is left undisturbed a reapplication may be necessary after two months.
- More PAM applications may be required for steep slopes, silty and clayey soils (USDA Classification Type “C” and “D” soils), long grades, and high precipitation areas.
- When PAM is applied first to bare soil and then covered with straw, a reapplication may not be necessary for several months.
- Discharges from PAM treated areas must be monitored for non-visible pollutants.

## 12. Applications

### Polymer Enhanced Soil Stabilization

To stabilize the soil on any slope conditions to prevent erosion. Polymer additions can assist temporary or permanent grassing by binding the seed, fertilizer, mulch, and soil together until the grass germinates.

#### a) *Hydroseeding*

A soil-specific polymer can be added into the hydroseeding mix and applied over slopes. It has been tested when mixed with blended fiber matrix (BFM). The polymer reacts with the soil, binding the mulch, seed, fertilizer, and other additives to the soil, holding it together until vegetation is established. Matting can be applied over the top of the hydroseeded areas, especially in areas with steep slopes, to ensure that the hydroseed mix is not washed away should heavy runoff occur. The polymer combines soil chemistry and emulsion theory. This is the basis for BFM in that PAM increases tackifier characteristics and enhances the wood-based mulch.

- i. Application rate: varies by soil content and grade of slope.
  - Gentle to Moderate slopes (flat to 1V:4H)
    - High Clay Content: 10-20 # powder or 1.5-2.0 gallons emulsion
    - High Sand Content: 15-20 # powder or 1.5-2.0 gallons emulsion
  - Steep slopes (1V:3H to 1V:1H)
    - High Clay Content: 20-35 # powder or 1.5-2.5 gallons emulsion
    - High Sand Content: 25-50 # powder or 2.0-2.5 gallons emulsion
- ii. Polymer emulsion or powder shall be added to all hydroseeding mixes at the above application rates per 3000 gallons of water, and then applied at the rate of 3000 gallons of hydroseed mix/ acre (**NOTE: Emulsion and powder additions are limited by high viscosity, at the higher limits listed above.** Site testing will determine the correct polymer type.)
- iii. Polymer shall be added slowly as the final additive to the hydroseeding mix. Addition en-masse will cause clumping of the polymer and may cause clogging of the spraying equipment.
- iv. Due to the viscous nature of the polymers, the hydroseed mix should be applied to the soil as soon as possible after polymer has been added.
- v. Straw, mulch, matting, or jute cover may be applied over the hydroseeded application.

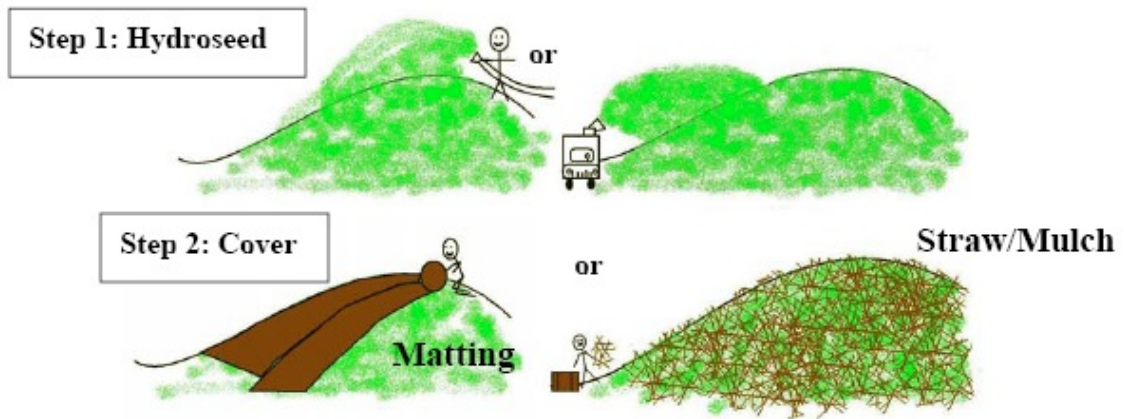

*Limitations:* Soil Samples must be tested for effectiveness so that a performance based criteria is implemented. Other limitations include slope steepness, type of clay (solubility, swelling characteristics, etc.)

Figure AIII-4: Hydroseeding Application.

b) *Direct Soil Application Using a Granular Powder*

A soil-specific polymer can be applied directly to the soil surface, using a seed/fertilizer spreader, either alone or as part of a mix. The polymer reacts with the soil, binding the mulch, seed, fertilizer, and other additives to the soil, holding it together until vegetation is established. Matting can be applied over the top of these areas, especially in areas with steep slopes, to ensure that the mix is not washed away should heavy runoff occur.

- i. Application rate: varies by soil content and grade of slope.
  - Gentle to Moderate slopes (flat to 1V:4H)
    - High Clay Content: 10-20 # powder
    - High Sand Content: 15-20 # powder
  - Steep slopes (1V:3H to 1V:1H)
    - High Clay Content: 20-35 # powder
    - High Sand Content: 25-50 # powder
- ii. Dry soil-specific polymer powder shall be applied using a seed or fertilizer spreader alone or may be mixed with other dry spread additives.
- iii. Straw, mulch, matting, or jute cover should be applied over the soil-specific polymer application.

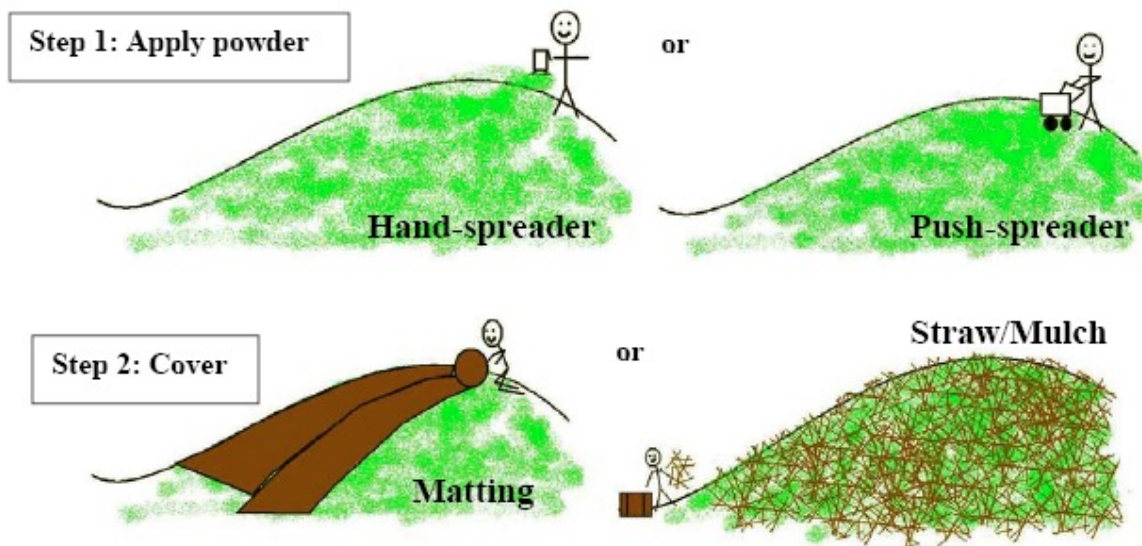

*Limitations:* Soil Samples must be tested for effectiveness so that a performance based criteria is implemented. Other limitations include slope steepness, type of clay (solubility, swelling characteristics, etc.)

Figure AIII-5: Granular powder direct soil application.

c) *Polymer Enhanced Armoring with Matting*

Polymer Enhanced Armoring is the process by which soft pliable matting such as jute, coir, coconut, hemp or burlap is placed onto the soil surface. A soil-specific polymer is then applied which reacts with the metals and clays within the soil to bind it together. This complex attaches to the matting creating a highly erosion-resistant surface that will support vegetation along with aiding in the attachment of fine particulate to the matting surface.

- i. For soil stabilization; can be used in conjunction with Channel Stabilization, Stream Crossings, Permanent Soil Reinforcing Matting, and Surface Roughening.
- ii. Application rate: varies by soil content and grade of slope.
  - Gentle to Moderate slopes (flat to 1V:4H)
    - High Clay Content: 10-20 # powder
    - High Sand Content: 15-20 # powder
  - Steep slopes (1V:3H to 1V:1H)
    - High Clay Content: 20-35 # powder
    - High Sand Content: 25-50 # powder
- iii. One or more layers of jute or other matting shall be applied to the surface of all exposed soil on 2:1 slopes or greater.
- iv. The matting must have ½” – 1” open area to allow for polymer, seed, and fertilizer to fall through the matting. If tighter weaved matting is used, apply the soil-specific polymer powder first.
- v. Ensure matting is flush to the soil surface to allow soil adherence and prevent erosion due to “tenting.”
- vi. Apply polymer powder on top of matting using a seed or fertilizer spreader or the powder can be mixed with other dry spread additives.

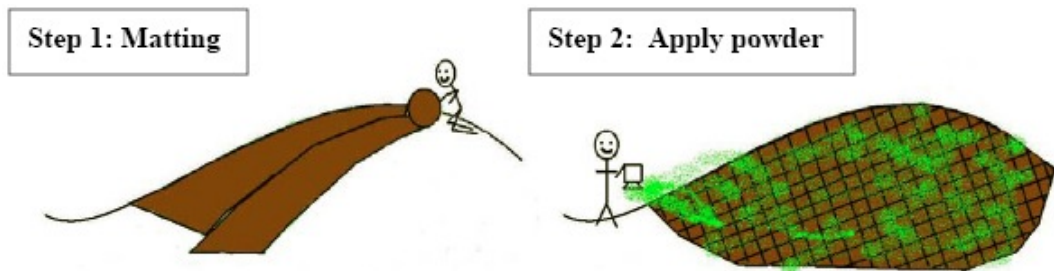
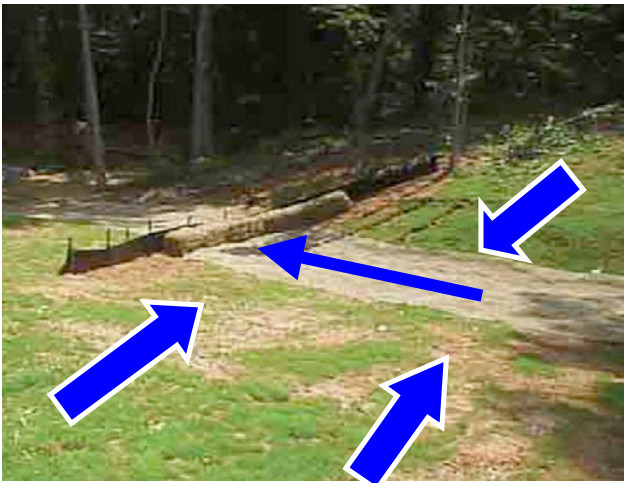

Figure AIII-6: Polymer-enhanced Armoring with Matting.

**Apply Matting flush to soil surface:**



**Application in areas of concentrated flow:**



**Armoring Application with Hydroseeder over Matting:**



*d) Polymer Enhanced Turf Reinforced Matting or Cover Matting*

Polymer Enhanced erosion control matting can be used on a temporary or non-temporary basis to stabilize the soil by supporting the grass roots and providing long-term protection. A soil-specific polymer can be applied directly to the soil surface, using a seed/fertilizer spreader, either alone or as part of a mix. The polymer reacts with the soil, binding the mulch, seed, fertilizer, and other additives together, which attaches to the matting creating a highly erosion-resistant surface that will help to support the vegetation until it is established. TRMs function as permanent matting but only after vegetation is established. Polymer applications can greatly increase the effectiveness of TRMs and matted surfaces. PAM increases the holding power of the soil and stops the potential for erosion under the TRM.

- i. Application rate: varies by soil content and grade of slope.
  - Gentle to Moderate slopes (flat to 1V:4H)
    - High Clay Content: 10-20 # powder
    - High Sand Content: 15-20 # powder
  - Steep slopes (1V:3H to 1V:1H)
    - High Clay Content: 20-35 # powder
    - High Sand Content: 25-50 # powder
- ii. One layer of jute or other matting shall be applied to the surface of all exposed soil on 2:1 or steeper slopes.
- iii. Apply polymer powder on top of matting using a seed or fertilizer spreader or may be mixed with other dry spread additives.
- iv. Ensure matting is flush to the soil surface to allow soil adherence and prevent erosion due to “tenting.”

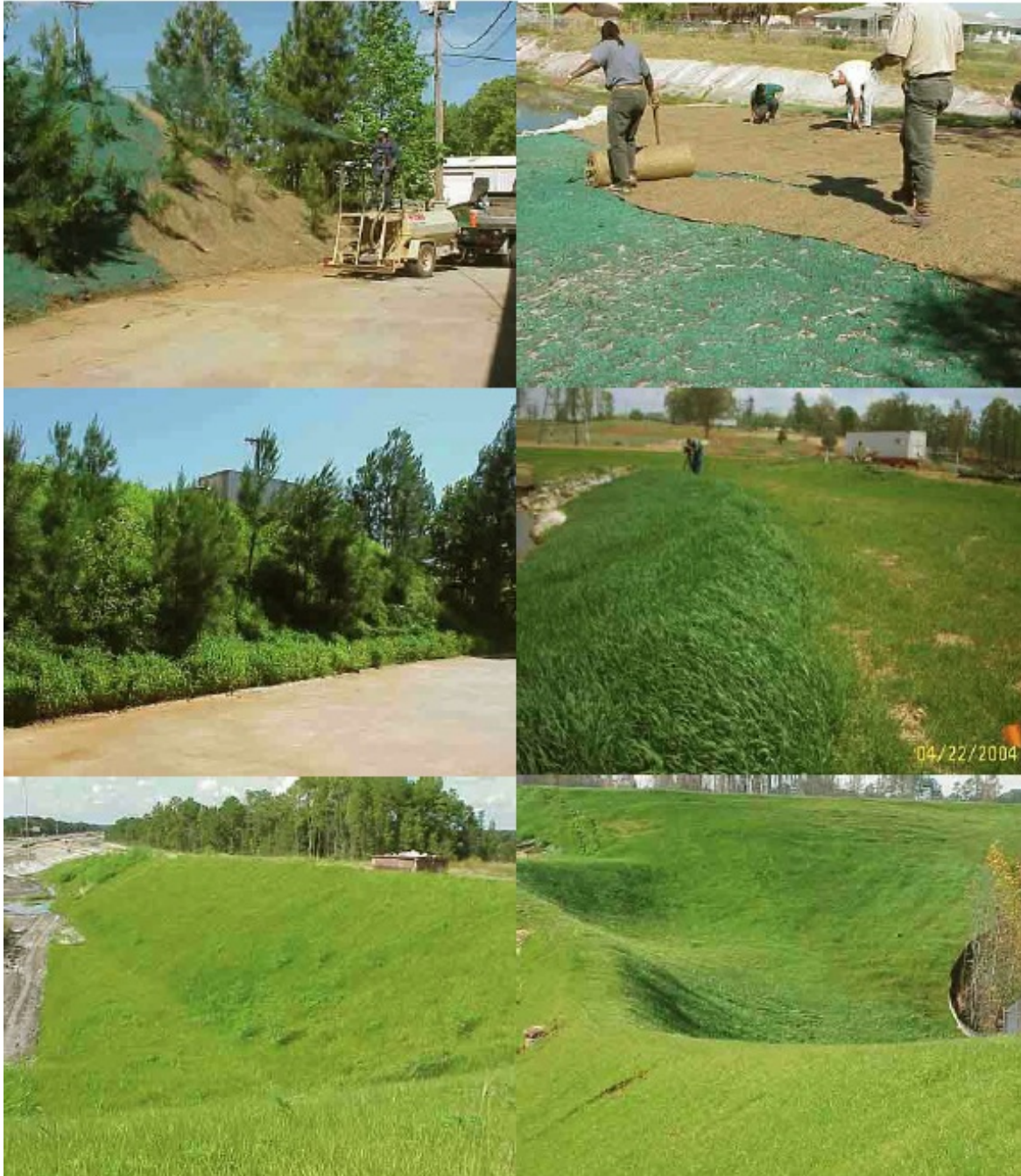

Figure AIII-7: Polymer-enhanced Turf Reinforced Matting.

e) *Polymer Enhanced Earth Berms*

An earthen berm is constructed at the edge of an embankment to prevent slope erosion, direct runoff to a down drain or catchments area, and protect working areas from surface runoff. These can be made more effective and protected from erosion by covering with jute fabric and applying with the correct site-specific polymer. The polymer reacts with the suspended particles in the runoff water, similar to polymer enhanced soft armor, binding and adhering them to the matting, protecting the berm from the erosive forces and greatly improving the water quality as it moves towards a detainment area or site discharge. It may be used in conjunction with ECB at the inside berm toe depending on the anticipated flows.

- i. Temporary earth berms are used to intercept runoff water and reduce slope erosion. These can be made more efficient by covering with jute matting and applying polymer powder.
- ii. One layer of jute or other matting shall be applied to the surface of the diversion, overlapping abutting pieces so that the upstream piece is on top of the downstream piece.
- iii. Apply dry polymer powder to the matting cover, using a seed or fertilizer spreader.
- iv. Application rate: varies by soil content and grade of slope.
  - Gentle to Moderate slopes (flat to 1V:4H)
    - High Clay Content: 10-20 # powder
    - High Sand Content: 15-20 # powder
  - Steep slopes (1V:4H to 1V:1H)
    - High Clay Content: 20-35 # powder
    - High Sand Content: 25-50 # powder



*Limitations:* Soil Samples must be tested for effectiveness so that a performance based criteria is implemented. Other limitations include slope steepness, type of clay (solubility, swelling characteristics, etc.)

Figure AIII-8: Polymer-enhanced Earth Berms.



f) *Polymer Enhanced Channel Stabilization*

Erosion occurs along areas of concentrated flow, causing rills to develop and channels to widen. To protect the channel bed, it is Soft Armored, and covered with soft pliable open-weave matting such as jute. A soil-specific polymer is used to stabilize a channel either with constant or intermittent flow, binding the soil to prevent erosion. Plastic sheeting may need to be laid down beneath the matting when used as a water quality device, especially if the channel is in highly erosive or contains sandy soils.

- i. Application rate: varies by soil content and grade of slope.
  - Gentle to Moderate slopes (flat to 1V:4H)
    - High Clay Content: 10-20 # powder
    - High Sand Content: 15-20 # powder
  - Steep slopes (1V:3H to 1V:1H)
    - High Clay Content: 20-35 # powder
    - High Sand Content: 25-50 # powder
- ii. One or more layers of jute or other matting shall be applied to the surface of the channel, overlapping abutting pieces so that the upstream piece is on top of the downstream piece.
- iii. Apply polymer powder on top of matting using a seed or fertilizer spreader or may be mixed with other dry spread additives.

PAM will not replace the need to assess the shear stress and velocity limitations of TRM. It can reduce the erosion potential.

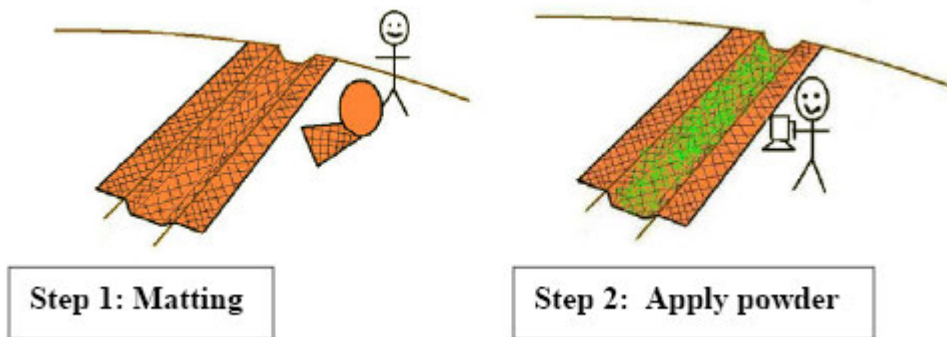

*Limitations:* Soil Samples must be tested for effectiveness so that a performance based criteria is implemented. Other limitations include slope steepness, type of clay (solubility, swelling characteristics, etc.)

Figure AIII-9: Polymer-enhanced Channel Stabilization.

*g) Stream Crossing and Culvert Stabilization*

A stream crossing is a bridge or pipe structure protecting a watercourse used when a roadway crosses over a stream or waterway to prevent damage from construction equipment. The slope from the roadway down to the streambed can be protected from erosion by applying polymer enhanced Soft Armoring. Soft pliable open-weave matting is laid along the slopes on either side of the roadway, and is then applied with the correct soil-specific polymer. The polymer reacts with the metals and clays within the soil to bind it together, which attaches to the matting creating a highly erosion-resistant surface and prevents erosion around the structure.

- i. Application rate: varies by soil content and grade of slope.
  - Gentle to Moderate slopes (flat to 1V:4H)
    - High Clay Content: 10-20 # powder
    - High Sand Content: 15-20 # powder
  - Steep slopes (1V:3H to 1V:1H)
    - High Clay Content: 20-35 # powder
    - High Sand Content: 25-50 # powder
- ii. One or more layers of jute or other matting shall be applied to the soil surface surrounding the stream crossing, where erosion would be present.
- iii. Apply polymer powder on top of the matting using a seed or fertilizer spreader or may be mixed with other dry spread additives.



Figure AIII-10: Stream Crossing or Culvert Stabilization.

## Polymer Enhanced Runoff Treatment

### **What is its purpose?**

To protect drainage channel against erosion due to flowing water.

### **Where and how is it commonly used?**

- In drainage channels where vegetation needs to be established and significant flows occur

### **When should it be installed?**

- While construction activities are occurring.
- After construction activities are finished.

### **When should it not be installed?**

- Over impervious surfaces.
- On very rough ground.

### **What needs to be inspected?**

- Does the RECP display any damage?
- Have check structures (staple or trench) been installed?
- Are sufficient numbers of staples used?
- Was seed applied?
- Was the channel bed smooth when the RECP was installed?
- Is water flowing under the blanket and causing erosion?
- Is the correct material used?
- Should hay/straw mulch be used?

### **What maintenance activities can be expected?**

- Repair and replacement of material.
- Repair of eroded ground.

### ***NOTES***

Erosion Control Blankets (ECBs) are composed of natural material including straw, straw-coconut, coconut (or coir), wood excelsior, and so forth. They should be held in place with netting sewn on both sides of the material.

One type of Turf Reinforcement Mats (TRMs) is composed of 100% polypropylene or nylon and held in place with netting sewn on both sides of the material.

Another type of TRM is composed of straw-coconut or coconut matter reinforced with strands of polypropylene threads and all held in place with netting sewn on both sides of the material.

Designers must complete shear stress and velocity calculations in selecting an ECB or TRM for drainage channels.

Additional information about ECBs and TRMs can be found at [www.ectc.org](http://www.ectc.org).

Jute materials are effective, biodegradable and low cost. They are a commonly used BMP in Florida.

## Polymer Enhanced Stormwater Treatment

Site-specific polymers can be used to clarify runoff, removing sediment and reducing the total suspended solids.

### 1. Polymer Enhancement for Erosion Control & Water Quality

#### *a) Drop Inlet Barriers*

A sediment trap used to prevent silt from entering the pipe system. The sediment is trapped outside of the barrier, clarifying the water as it enters the inlet.

#### *b) Silt Fence, Square*

A wood frame covered with silt fence or filter fabric is constructed to encircle the drop inlet and protect the inlet from being filled with sediment. Soil-specific polymer is applied to the soil surrounding the inlet and then covered with a layer of jute fabric. The Polymer Enhanced Armoring application will reduce water undercutting the drop inlet device. As the turbid runoff water passes across the jute matting with site-specific polymer, it reacts with the site-specific polymer clarifying the water and dropping out the suspended particles.

- i. Install silt fence or filter fabric to enclose the drop inlet. Space support posts evenly, to a maximum of 3 feet apart. Drive the posts 1.5 feet into compacted fill around the inlet.
- ii. The silt fence or filter fabric should be designed to allow at least 70 GPM/ft<sup>2</sup> of water to pass through it. FDOT approved silt fence or equivalent.
- iii. Wire backed silt fence can be used if additional support is needed.
- iv. Cross brace in corners to prevent collapse.
- v. Apply a layer of jute or other soft pliable matting on the ground around the outside of the inlet barrier.
- vi. Apply the appropriate soil-specific polymer powder over the matting as outlined in the section Polymer Enhanced Armoring with Matting.
- vii. Inspect and repair as needed, remove accumulated sediment after every storm.



*Limitations:* Inflow values must not exceed outflow values. Suggested outflow value is to be greater than 70 gpm/sq. ft of silt fence areas. This implies that the standard woven or needle punched silt fence materials may not be adequate. A monofilament woven material may suffice for low flows. In addition, proper installation is critical.

Figure AIII-11: Polymer-enhanced erosion control.

*c) Silt Fence, Round*

A ring of silt fence or filter fabric is constructed to encircle the drop inlet and protect the inlet from being filled with sediment. Further polymer enhancement using an Armoring application as outlined earlier in this section protects the inlet barrier from being undercut and compromised. As the runoff water passes through the layer of silt fence and jute matting applied with polymer it reacts with the site-specific polymer to clarify the water. The ring configuration is used when the sediment load is very high and is likely to collapse a square structure.

- i. Install silt fence or filter fabric to encircle drop inlet. Space the support posts evenly, to a maximum of 3 feet apart. Drive the posts 1.5 feet into compacted fill around the inlet.
- ii. Make sure that the silt fence is as level as possible.
- iii. The silt fence or filter fabric should be designed to allow at least 70 GPM/ft<sup>2</sup> of water to pass through it. FDOT approved silt fence or equivalent.
- iv. Wire backing can be added to the silt fence to provide additional support.
- v. Apply a layer of jute or other soft pliable matting to the ground around the outside of the inlet barrier.
- vi. Apply the appropriate soil-specific polymer powder over the matting as outlined in the section Polymer Enhanced Armoring with Matting.
- vii. The velocity of the runoff water should be reduced when approaching the drop inlet, to allow for ponding. The field of jute matting applied with the site-specific polymer can prevent undercutting and failure of the inlet barrier.
- viii. Inspect and repair as needed, remove accumulated sediment after every storm.



Figure AIII-12: Polymer-enhanced erosion control around drop inlet.

*d) Filter Stone/ Gravel Ring*

A ring of filter stone or gravel is used to protect the drop inlet from being filled with sediment. As the runoff water passes over the cover of jute matting applied with the site-specific polymer and through the stone the polymer reacts with the sediment within the runoff, forming large particles that are trapped between the filter stones, which clarifies the water.

- i. Install around drop inlet, the bottom of the barrier must be sunk into the ground to prevent water and sediment from just going under the barrier.
- ii. Lay jute matting and apply with polymer powder over the ground outside the ring and over the top of the filter stone to reduce the erosion and prevent it from being undercut during heavy flow.

- iii. Application rate: 10-20 pounds of polymer powder/ acre but not greater than 25 pounds/ acre.
- iv. The velocity of the runoff water should be reduced when approaching the inlet barrier to allow ponding to occur.
- v. Inspect and repair as needed, remove accumulated sediment after every storm.

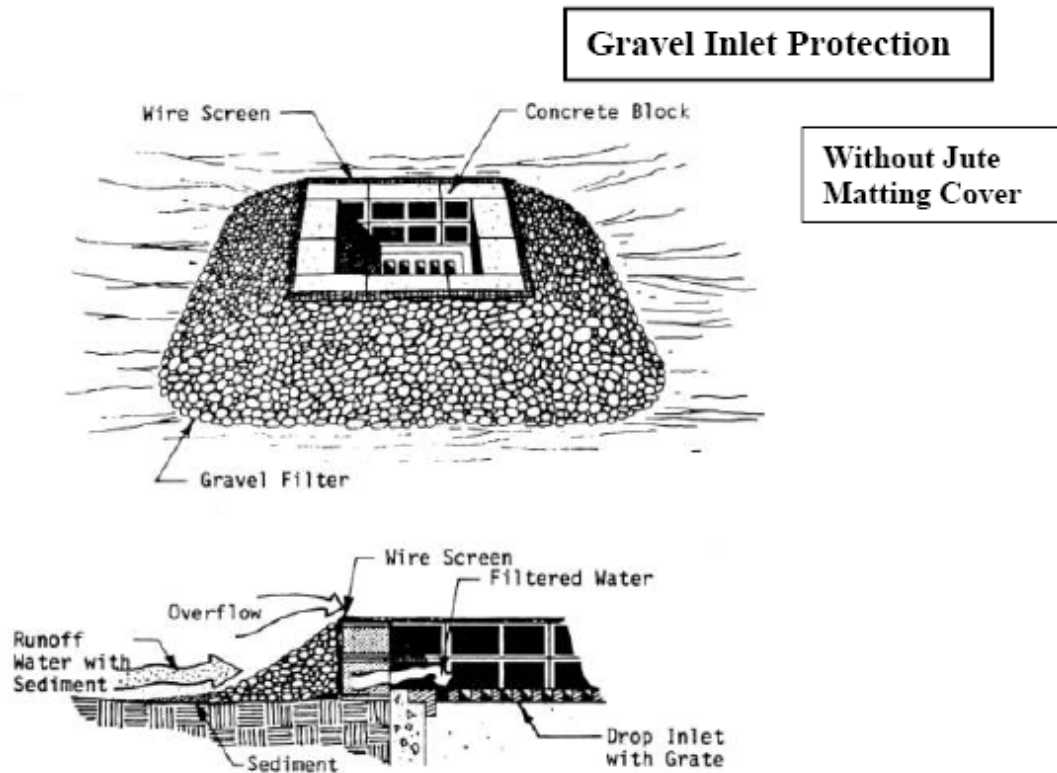

Figure AIII-13: Polymer-enhanced filter stone or gravel ring.

Polymer Enhanced Retrofits

A device or structure placed in front of a permanent stormwater structure to serve as a temporary sediment filter and water removal device. By introducing polymer logs to the turbid water within the permanent stormwater structure up stream, the polymer reacts with the metals and clays within the soil to bind it together, allowing the suspended sediment to be collected using jute or other organic matting downstream. The application of jute matting to the filter stone can greatly enhance capture of particulate and colloidal clay after reaction with the polymer logs.

- i. Install polymer logs inside a retrofit and in upstream water conveyance devices, to treat the water after it has moved through the filter stone.
- ii. Place the polymer logs so that the water flows over and around them. The number of logs is determined by the flow rate of the water. Longer mixing times will have the best reduction of turbidity.
- iii. Check dams or filters need to be installed upstream of the polymer logs to ensure that they are not overwhelmed with sediment.
- iv. Jute or other organic matting must be used downstream of the polymer logs to collect the particulate that is formed. Apply the correct polymer to the jute matting for water quality as

shown below.

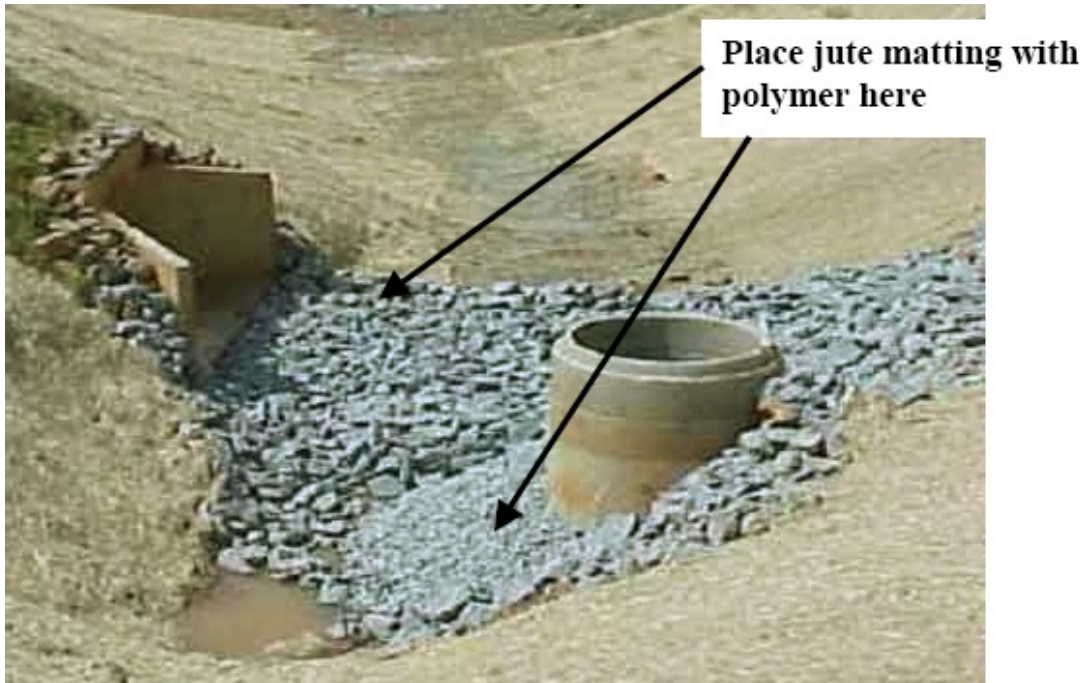

*Limitations:* It will only work well when the rock anchors the matting. Unless is maintained, the treated water flow through the jute matting may cause blockage of the rock barrier around the riser pipe.

Figure AIII-14: Polymer-enhanced retrofits.

### Outlet Protection

A pipe or box culvert outlet headwall with an apron and dissipater blocks used to prevent erosion and slow water. It is used in conjunction with site-specific polymer logs secured upstream of the outlet within the stormwater system. The outlet is enhanced through the use of polymers by laying down jute matting over the dissipater rocks and applying with a soil-specific polymer powder. The reacted sediment attaches to the matting creating a highly erosion-resistant surface along with producing a surface area that aids in attaching fine particulate resulting in increased water quality.

- i. Secure the appropriate site-specific polymer logs in the stormwater system far enough above the outlet to allow for adequate mixing to occur.
- ii. Cover exposed soil and riprap around the outlet with a layer of jute matting to allow particle adhesion of flocculated material and prevent erosion of exposed soil below riprap if heavy flow occurs.
- iii. Apply polymer powder on top of matting using a seed or fertilizer spreader or may be mixed with other dry spread additives.
- iv. Application rate: 15-20 pounds of polymer powder/ acre but not greater than 25 pounds/ acre.

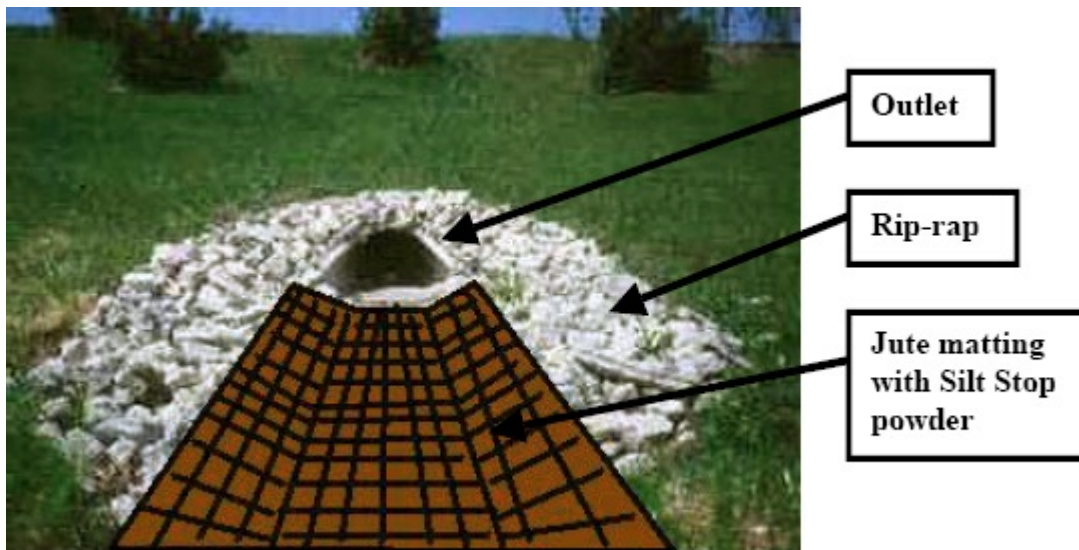

*Limitations:* If riprap is being placed under the jute, there may be damage to the material for significant flows. It is for this reason that assessing the shear stress and velocity needs to be completed as does placing rock anchors on top of the material.

Figure AIII-15: Polymer-enhanced Outlet Protection.



Polymer Log Enhanced Down Drains

A temporary or permanent pipe used to convey runoff safely down a slope. By introducing polymer logs to the turbid water within the permanent stormwater structure, the polymer reacts with the metals and clays within the soil to bind them together. A layer of jute matting is laid at the outlet at the bottom of the slope and applied with a soil-specific polymer powder. The reacted sediment attaches to the matting creating a highly erosion-resistant surface and clarifying the runoff water.

- i. Cover exposed soil around the top of the down drain pipe with jute or other matting to prevent erosion.
- ii. Apply polymer powder on top of matting using a seed or fertilizer spreader or may be mixed with other dry spread additives.
- iii. Application rate: 15-20 pounds of polymer powder/ acre but not greater than 25 pounds/ acre.
- iv. Polymer logs can be placed in the down drain at the top of the slope, if the runoff water is extremely turbid. (Do not impede flow of water entering down drain.)
- v. At the bottom of the down drain, create a dispersion field by laying jute matting applied with polymer powder, allowing the water to spread out and slow its velocity before hitting the silt fence.
- vi. The silt fence should be designed to allow at least 70 GPM/ft<sup>2</sup> of water to pass through it. FDOT approved silt fence or equivalent.

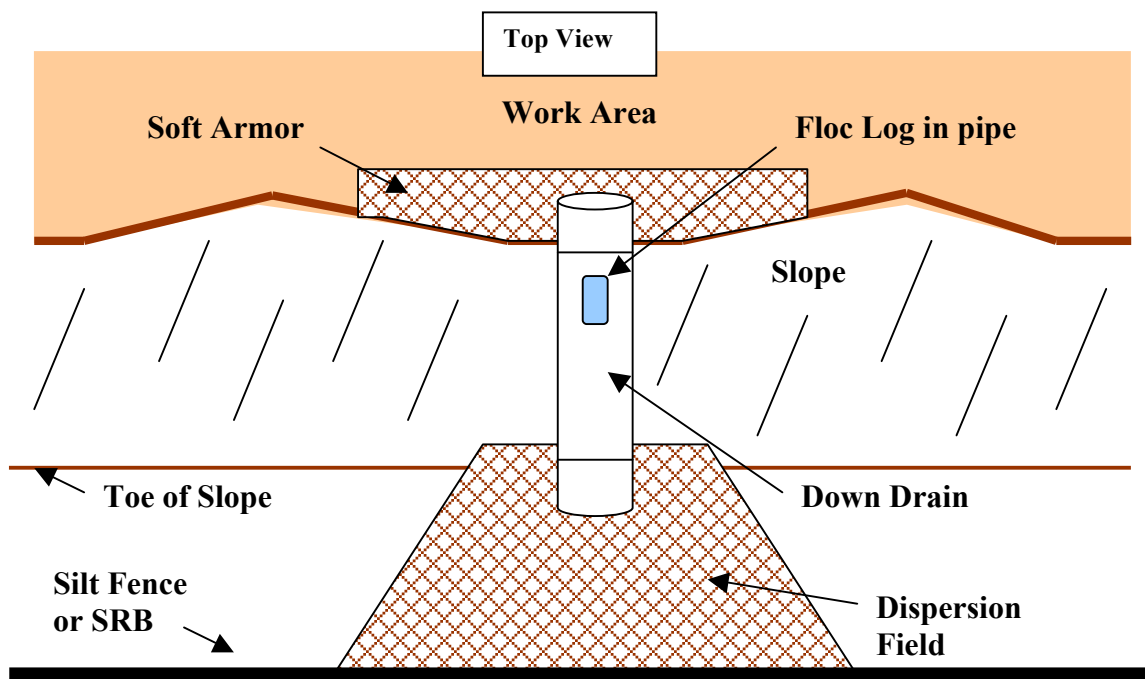

*Limitations:* High flow velocities will occur at the discharge end of the slope drain. Unless there is a great distance between the slope drain discharge end and the silt fence, and a pond is created, the silt fence barrier may be destroyed if the inflow values are greater than outflow.

Figure AIII-15: Polymer Log Enhanced Down Drains.

Polymer Enhanced Check Dams

Check Dams are used to reduce flow velocity in areas of concentrated flow to reduce the erosive capabilities of the water and allow suspended sediment to settle out. It should not be used in flowing streams.

*a) Rock check dams*

A check dam constructed of rocks, covered in jute fabric and applied with a site-specific polymer powder. The addition of jute or similar matting and the application of the soil-specific polymer powder can increase particle collection capabilities of the check system. The polymer reacts with the suspended particles, binding them together and adhering them to the matting.

- i. Cover with a layer of jute or coconut matting, secure with some spare rocks.
- ii. Apply dry polymer powder to the matting cover, using a seed or fertilizer spreader. Application rate: 10-20 pounds of powder/ acre but not greater than 25 pounds/ acre.
- iii. If using in conjunction with polymer logs, place the logs on the downstream side of the rock checks, securing with rebar or wooden stakes.

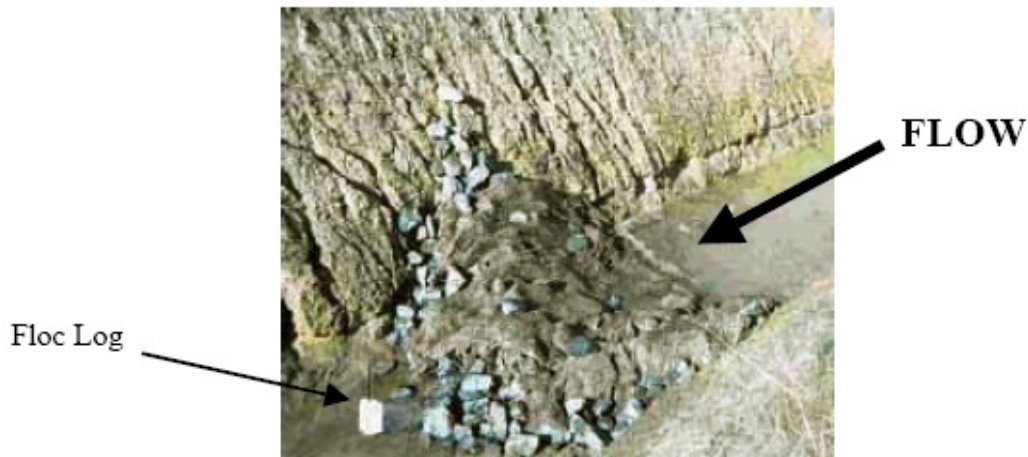

Figure AIII-16: Polymer-enhanced Check Dams.

## 2. *Sediment Retention Barriers (SRB)*

A double row of silt fence, standing about 4-6 feet apart, filled with loose mulch, straw, woodchips, or other organic matter mixed or blended with the site-specific polymer. It is used on graded sites to trap the fine sediment and clays that flow through the silt fence barrier. With the use of the site-specific polymer, water clarity can be greatly improved while utilizing the function of the silt fence.

### a) *Mass Grading Sites/ Grading Sites*

A double row of silt fence filled with loose mulch treated with the site-specific polymer is used to clarify runoff as it moves off of the site. The polymer within the mulch reacts with the suspended sediment, binding it into large particles that are trapped within the mulch, clarifying the runoff.

- i. Install in areas where runoff will exit a site, keeping the installation as level as possible.
- ii. Place perpendicular to flow.
- iii. Use silt fence designed to allow at least 70 GPM/ft<sup>2</sup> of water to pass through it. FDOT approved silt fence or equivalent.
- iv. Place 2 rows of silt fence 4-6 ft apart. Place loose straw or mulch 3 ft deep between the silt fences (do not compact).
- v. Dry site-specific polymer powder should be spread evenly throughout the straw or mulch using a hand seed or fertilizer spreader.



*Limitations:* Inflow values must not exceed outflow values. Suggested outflow value is to be greater than 70 gpm/sq. ft of silt fence areas. This implies that the standard woven or needle punched silt fence materials may not be adequate. A monofilament woven material may suffice for low flows.

Figure AIII-17: Sediment Retention Barriers.

*b) Sediment Ponds using SRB Applications*

SRB is used to capture sediment and treat the runoff as it moves into SCS. The polymer within the SRB reacts with the suspended sediment, binding it into large particles that are trapped within the SRB aiding in clarifying the runoff.

- i. Install the SRB to surround the inlet ditch as it enters the retention pond.
- ii. Make sure that the silt fence is as level as possible.
- iii. Make the SRB large enough to handle 50% or greater of the design stormwater flow. This will contain most of the sediment and clarify the water that moves through it.
- iv. Further sectioning of the retention pond can be done using SRBs; however the key is to make sure the silt fence is level.
- v. Use silt fence designed to allow at least  $70 \text{ gpm/ft}^2$  of water to pass through it. FDOT approved silt fence or equivalent.
- vi. Place 2 rows of silt fence 4-6 *ft* apart. Place straw or mulch 3 *ft* deep between the silt fences (do not compact).
- vii. Dry polymer powder should be spread evenly throughout the straw or mulch using a hand seed or fertilizer spreader.
- viii. The polymer powder used will vary with the type of clay and organic content of the site; have soil and water samples from the site tested for the appropriate polymer.
- ix. All exposed soil around the retention pond must be treated with polymer powder to prevent contamination of clarified waters.

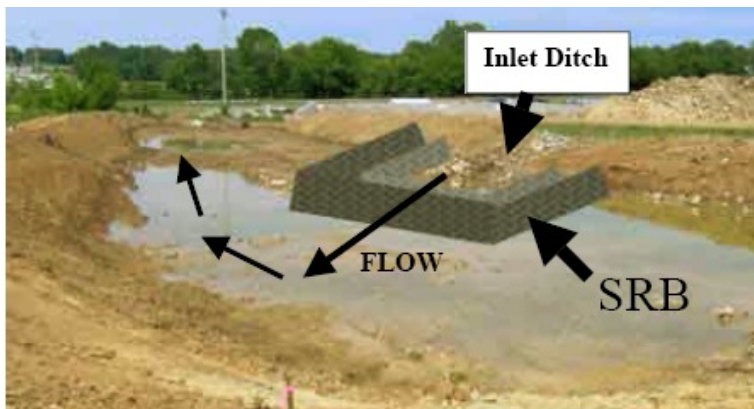

*Limitations:* Inflow values must not exceed outflow values. Suggested outflow value is to be greater than  $70 \text{ gpm/sq. ft}$  of silt fence areas. This implies that the standard woven or needle punched silt fence materials may not be adequate. A monofilament woven material may suffice for low flows.

Figure AIII-18: Polymer-enhanced Sediment Ponds using SRBs.

*c) Drop Inlets with Polymer Enhancement*

A double ring of silt fence or filter fabric is constructed to encircle the drop inlet and filled with mulch or woodchips applied with the site-specific polymer used to protect the inlet from being filled with sediment. As the runoff water passes through the layers of silt fence and mulch applied with polymer it reacts with the site-specific polymer clarifying the water.

- i. Install the silt fence or filter fabric to encircle drop inlet. Space the support posts evenly, to a maximum of 3 feet apart. Drive the posts 1.5 feet into compacted fill around the inlet.
- ii. Make sure that the silt fence is as level as possible.
- iii. Use silt fence designed to allow at least  $70 \text{ gpm/ft}^2$  of water to pass through it. FDOT approved silt fence or equivalent.
- iv. Place 2 rows of silt fence 4-6 ft apart. Place straw or mulch 3 ft deep between the silt fences (do not compact).
- v. Dry polymer powder should be spread evenly throughout the straw or mulch using a hand seed or fertilizer spreader.
- vi. Inspect and repair as needed, remove accumulated sediment after every storm.

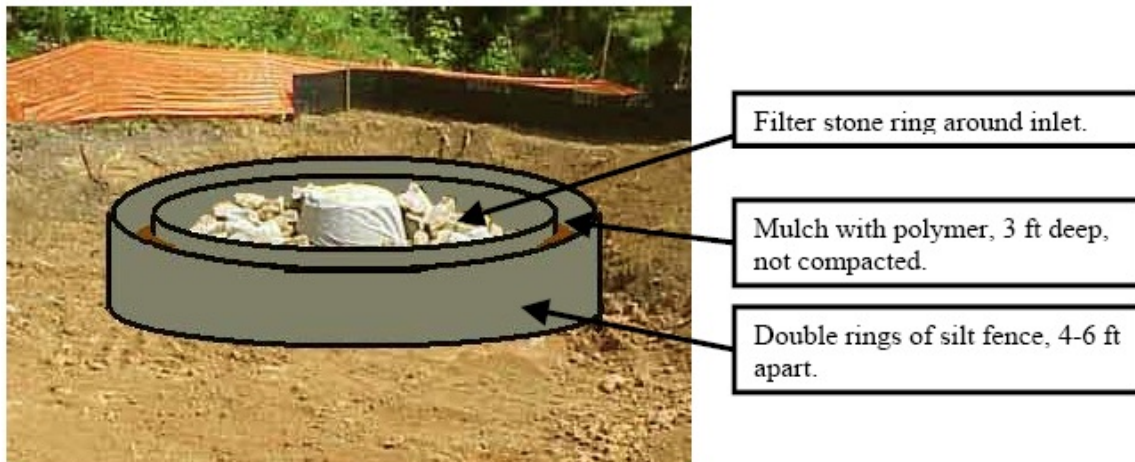

*Limitations:* Inflow values must not exceed outflow values. Suggested outflow value is to be greater than  $70 \text{ gpm/sq. ft}$  of silt fence areas. This implies that the standard woven or needle punched silt fence materials may not be adequate. A monofilament woven material may suffice for low flows.

Figure AIII-19: Polymer-enhanced Drop Inlet Protection.

## Polymer Enhanced Water Treatment Systems

### **Polymer Log Mixing Systems**

To introduce site-specific polymer logs, to turbid waters in such a manner to facilitate mixing and reaction between the polymer and the suspended particles.

#### *a) Polymer Enhanced Mixing Ditch System*

This application is intended for use on temporary or changing sites, where the excavation of a large area or pond is not feasible, and is also used for dewatering operations. A ditch is built up, either by digging out the bed or building up the walls, and can be lined with plastic to prevent erosion if needed. The ditch is lined with jute or similar matting. Checks are placed along the ditch, to increase turbulence and create mixing. Polymer logs are secured along the raceway, allowing the water to mix with the polymer and begin reacting with the suspended sediment.

- i. Open ditch system is an alternative to a pipe or closed drain systems, especially before permanent pipe structures have been installed.
- ii. Cover the exposed soil with jute matting and apply polymer powder to prevent erosion. With highly erosive soils, protection with geotextile or plastic sheeting may be necessary.
- iii. Build checks in the ditch and secure the polymer logs on the downstream side of each check. Make sure that the logs are not resting in mud, drive rebar “feet” into the logs to raise them slightly if needed.
- iv. Logs should be placed in a series. The number of logs is determined by the flow rate of the water and the length of the mixing chamber is determined by the reaction time required for the polymer.
- v. Used in conjunction with a settling pond upstream and usually with a sediment collection system (baffle grids, riprap, settling pond, filter, dispersion field, etc.) downstream.



*Limitations:* PAM does not replace the need to assess shear stress and velocity limitations of a TRM. However, PAM will reduce the erosion potential and results in better performance. Limitations include slope steepness, type of clay (solubility, swelling characteristics, etc.) Once again, samples must be tested for effectiveness so that a performance-based criteria is implemented.

Figure AIII-20: Polymer Log Mixing Systems.

*b) Polymer Log Wire Basket*

This system is for use on aquatic sites, when diversion of the water is not feasible, especially for stormwater ditch and drain cleanout projects. A large wire basket is constructed to hold site-specific polymers, allowing water to pass over and around them. The basket with the polymer is placed just downstream of the work site, to allow the turbid water to mix with the polymer and begin to react.

- i. A wire basket is used to introduce polymer into an aquatic site, when diversion of the water is not feasible. Especially for stormwater ditch and drain cleanout projects.
- ii. The wire basket is designed to hold a number of polymer logs and allow water to pass over and around them.
- iii. The basket should be placed closest to the point of turbidity without interfering with the work site; to allow adequate mixing with the polymer as the sediment is introduced into the water column.
- iv. Additional mixing structures may need to be placed in the stream at the same point that the wire basket is located to create turbulence to facilitate appropriate mixing.
- v. The number of polymer logs needed is determined by the flow rate of the water, and distance between the basket and the work site is determined by the reaction time required for the polymer.
- vi. Sediment collection system should be constructed downstream of the work site, to collect the sediment that is flocculated.



*Limitations:* Monitoring is advisable for water quality concerns.

Figure AIII-21: Polymer Log Wire Basket Systems.



Polymer Enhanced Particle Collection

a) *Dispersion Field*

A delta laid with jute or similar matting treated with site-specific polymer to allow for collection of fine sediment particles from high velocity pumping. The dispersion field is to be used in conjunction with a mixing system and possibly a primary sediment collection device.

- i. Direct the runoff from the site through a soil-specific polymer mixing system, and over a series of riprap to slow the velocity of the water.
- ii. Open the channel up into a dispersion delta. This dispersion field should be covered in jute and applied with the site-specific polymer powder, to provide a surface for the particles to adhere to. The velocity of the water in the channel determines the size of the delta; it needs to be large enough that the velocity is reduced to 0.5 *ft/sec*.

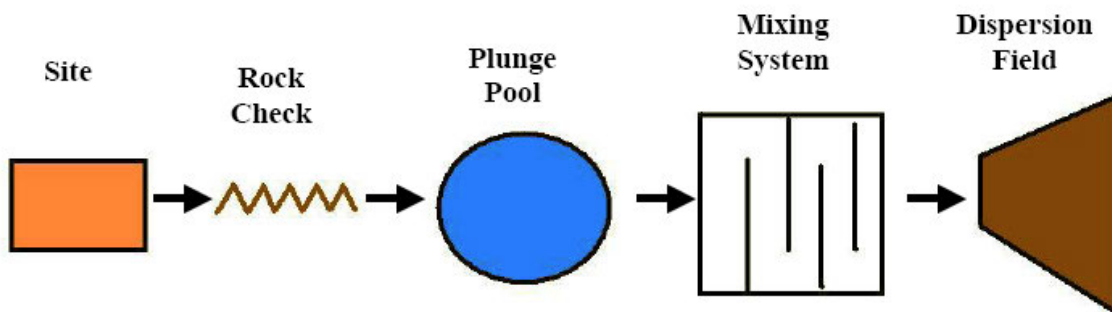
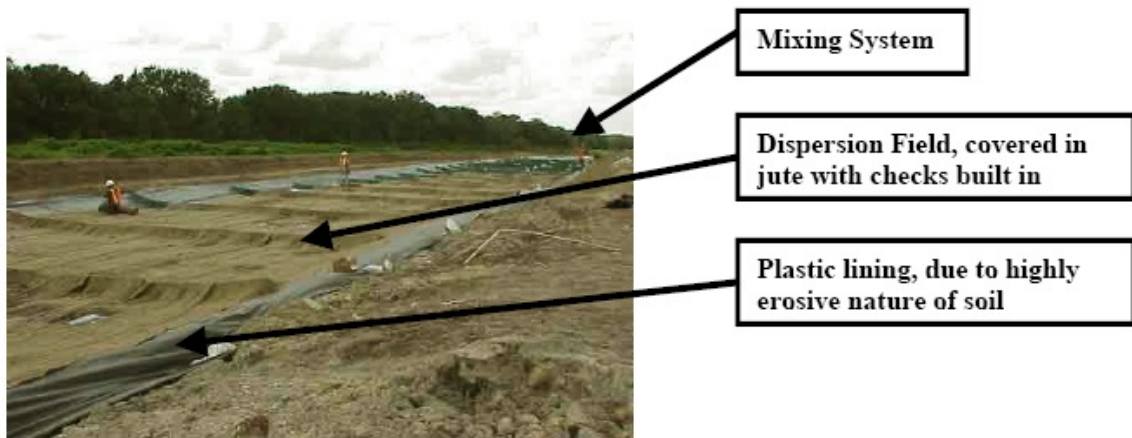

Figure AIII-22: Polymer-enhanced Particle Collection.

*b) Baffle Grids*

A series of panels made of jute or similar fabric, to collect fine particles from turbid water after polymer reaction. The panels can be treated with a site-specific polymer as well for short-term increased performance to aid in further water clarification.

- i. This device is for maintaining water quality, not sediment control.
- ii. Pump or drain into a plunge pool surrounded by a riprap apron.
- iii. Direct the overflow from the plunge pool or fore bay/ grit pit to collect the heavier sediment.
- iv. Direct the overflow from the grit pit through a series of baffle panels, made of jute fabric and applied with polymer powder.
- v. The baffle grids are used in conjunction with a mixing system or polymer logs in storm drains, where turbid water is treated with polymer and then sent through the baffle grids. Alternately, this can be used in conjunction with existing stormwater structures. Secure the appropriate polymer logs into the storm drain system, with adequate mixing over each log, while allowing for the correct mixing time before discharge to the grid. Cinder blocks or rubble can be placed into the open ditch or trough to facilitate mixing.

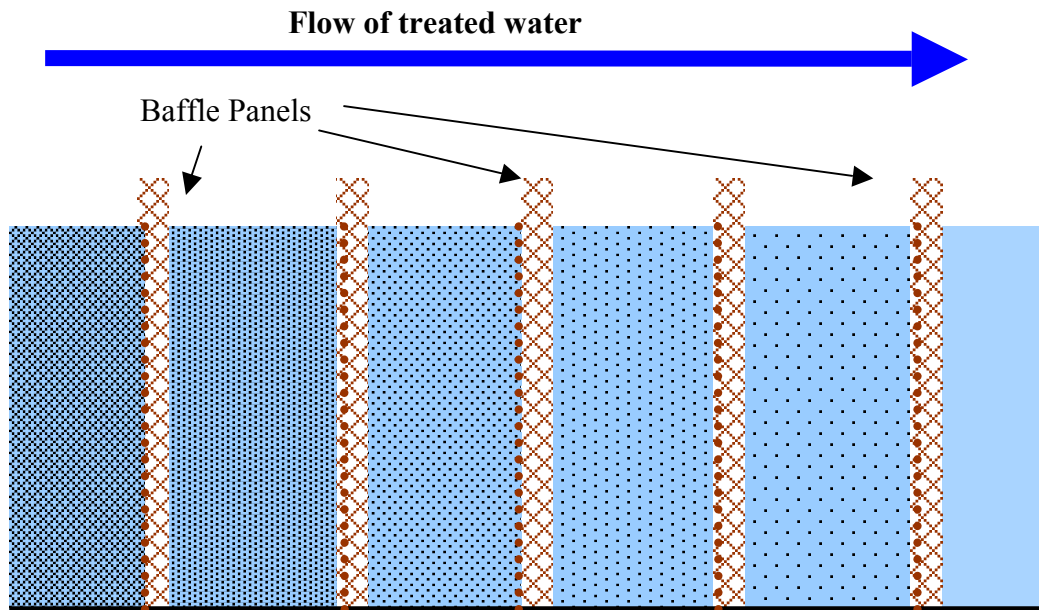

Figure AIII-23: Polymer-enhanced Baffle Grids.



*Limitations:* It is to be noted that this application is for “polishing up” the water after it has undergone maximum treatment to remove sediment. This application is not adequate water clarity control by itself, it is intended to be used in conjunction with other stormwater treatment systems.

Figure AIII-24: Polymer-enhanced Baffle Grids in the Field.

*c) Particle Curtains*

A series of curtains made of jute and coconut fabrics attached to floats to be used in wet ponds and flowing waterways to collect fine particles from turbid water after polymer reaction. Particle curtains are to be used in conjunction with site-specific polymers upstream of the curtains.

- i. Secure the site-specific polymer far enough upstream to allow for appropriate mixing with the turbid water. Make sure that the water can flow over and around the polymer logs, adding mixing structures if needed to increase turbulence around the polymer logs to facilitate proper mixing.
- ii. Install the particle curtains in lines perpendicular to the flow across the sediment pond or waterway.
- iii. The particle curtains will float.
- iv. Inspect and repair or replace the particle curtains as required.



Figure AIII-25: Polymer-enhanced Particle Curtains.

*d) Wattle or Check Collection System*

To be used for in-stream particle collection. The wattles are placed perpendicular to the flow to create a series of checks that will trap sediment reacted with the site-specific polymer upstream. This can be improved by covering the wattles and the ditch line with jute fabric and applying the appropriate site-specific polymer powder. The polymer reacts with the suspended particles, binding them together and adhering them to the matting.

- i. Secure the appropriate site-specific polymer logs in the ditch or stormwater system far enough upstream of the wattles to allow for adequate mixing to occur.
- ii. Place wattles perpendicular to the flow of water.
- iii. Cover with a layer of jute or coconut matting, secure with stakes or rocks.
- iv. Apply dry polymer powder to the matting cover, using a seed or fertilizer spreader. Application rate: 10-20 pounds of powder/acre.

Figure AIII-26: Polymer-enhanced Wattle and Check Collection Systems.

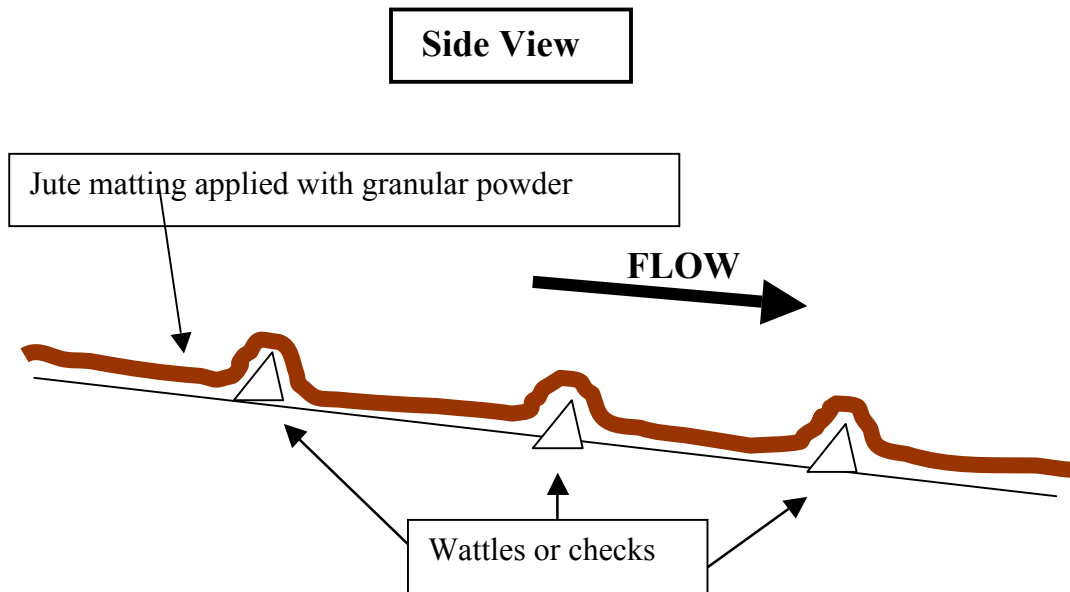

*Polymer Log Enhanced Level Spreaders*

Level spreaders are panels of organic fabric or silt fence, installed in lines across a sediment pond, perpendicular to the flow designed to increase settling time and increase the particle collection capabilities of the SCS. When used with site-specific polymer logs upstream within the runoff, the polymer log reacts with the colloidal clays, metals, and nutrients increasing particle size and decreasing settling time. This allows for very rapid settling time and greatly increased water quality.

- i. Secure the appropriate site-specific polymer logs in the stormwater system far enough above the sediment pond to allow for adequate mixing to occur.
- ii. Install lines of silt fence or organic panels perpendicular to the flow, in lines across the sediment pond, making sure they are as level as possible.
- iii. If using silt fence, use silt fence designed to allow at least 70 GPM/ft<sup>2</sup> of water to pass through it. FDOT approved silt fence or equivalent.
- iv. The heaviest of the reacted sediment will become trapped in the first cell, with smaller and smaller particles being trapped in each successive cell, as the water will be slowed upon hitting each level spreader.

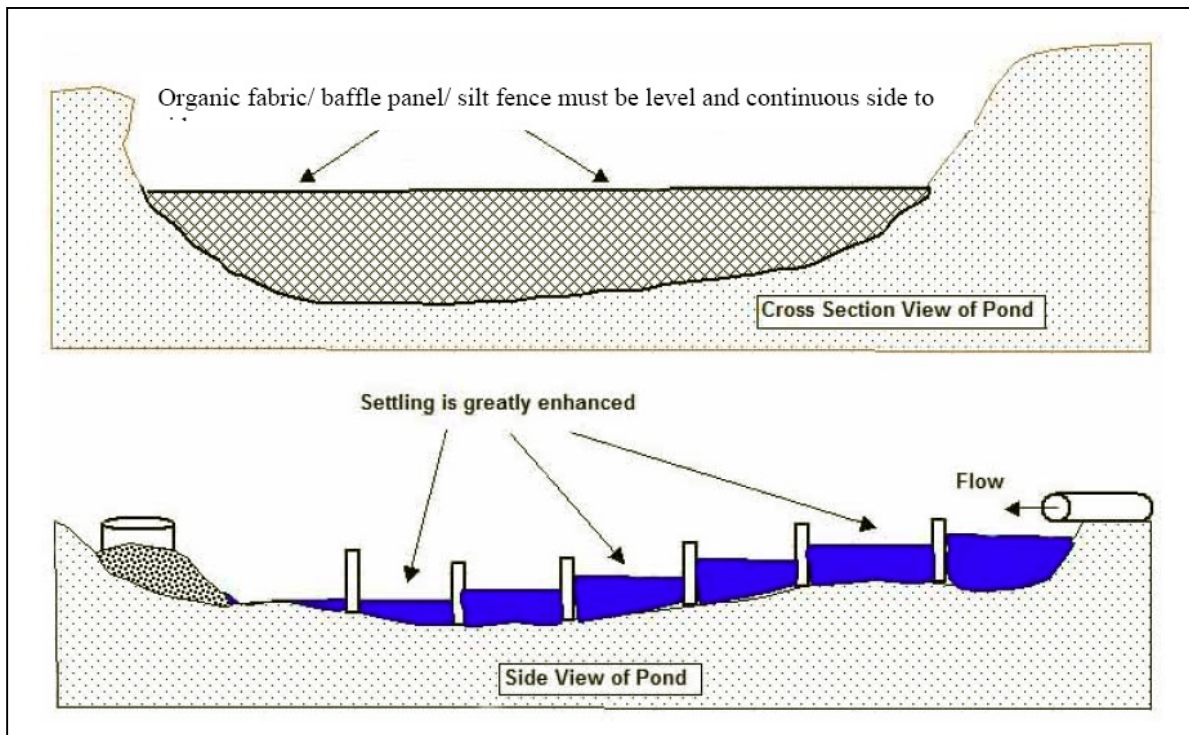

*Limitations:* There are limitations based on inflows. They must be sized to flow requirements on-site.

Figure AIII-27: Polymer-enhanced Level Spreaders.

### Polymer Enhanced Mud/Sediment Removal

When designed properly, a sediment pond will collect and retain sediment. To maintain optimum efficiency, the sediment needs to be removed. Highly saturated soils can be messy and difficult to remove without spills or dripping. Adding a soil-specific polymer to the soil and mixing it in, binding the soil together, thickening the soil and making it easier to remove.

- i. Pump off the water from the pond, leaving the wet sediment behind.
- ii. Apply polymer powder to the sediment, and use the bucket of the removal equipment to stir it into the mud, to a maximum of 3 feet deep/ application.
- iii. Application rate: 50 pounds of polymer powder/ 100-200 cubic yards. This rate may vary with clay/organic type and content.
- iv. Allow 10-20 minutes for the polymer to react with the soil, the more mixing you do, the less time this will take.
- v. The polymer will cause the sediment to thicken, making it easier to remove without liquid spills or dripping.
- vi. The thickened sediment can then be used as a topsoil amendment to improve vegetation establishment. This material is not suitable for use as a structural fill.



Figure AIII-28: Polymer-enhanced Mud and Sediment Removal.

### Polymer Enhanced Dust Suppression

#### *a) Packed Dirt roads or traffic-ways*

- i. Application rate: 0.75 – 1.5 gallons of polymer emulsion/ 3000 gallons of water/ 1 acre coverage. (No less than 3000 gallons of water should be used, do not exceed 1.5 gallons of emulsion/ 1500 gallons of water)
- ii. Emulsion additions are limited by high viscosity, do not exceed 3.0 gallons emulsion/ 3000 gallons of water.
- iii. Spraying device with a mechanical agitator, mixing apparatus or hydraulic recirculation is best.
- iv. Equipment should be prepared for polymer use by treating with surfactant to prevent buildup of polymer within the machinery, especially at nozzles and spraying points.
- v. Add the polymer emulsion slowly to the water to prevent clumping and poor performance.
- vi. Allow 2-3 minutes of mixing time before spraying the site.
- vii. Once completed, wash out all equipment used to spray polymer to prevent polymer residue from building up and reducing efficiency.



Figure AIII-29: Polymer-enhanced Dust Suppression.



**ALUM**

## USE OF ALUM FOR SEDIMENT CONTROL

### WHAT IS ITS PURPOSE?

- To remove suspended solids and pollutants by enmeshment and absorption onto alum.
- To collect flocs of suspended sediments in runoff and store within sediment basins or ponds.

### WHERE AND HOW IS IT COMMONLY USED?

- Alum is injected into the flow stream containing turbid discharge to be treated.
- The injection is controlled using a variable speed chemical pump to feed alum at multiple treatment points.
- Alum is more effective in treatment of discharge that comes in contact with lime rock.
- The treatment process has to be carefully monitored.

### WHEN SHOULD IT BE INSTALLED?

- While construction activities are occurring.
- After construction activities are completed.

### WHERE AND WHEN SHOULD IT NOT BE INSTALLED?

- Alum treatment requires close monitoring of dosage and overdosing may be harmful.
- Where other compounds may violate toxicity requirements.
- Alum may lower pH and elevate levels of  $Al^{+3}$

### WHAT NEEDS TO BE INSPECTED?

- Inspect control units prior to forecast rain, daily during extended rain events, after rain events, weekly during the rainy season, and at two-week intervals during the non-rainy season.
- Alum control operational units are equipped with automatic feeders for low rate. These feeders must have alarms to alert operators of failure events. Inspection is needed to remedy such failed systems.

### WHAT MAINTENANCE ACTIVITIES CAN BE EXPECTED?

- Deposition of sediments from the use of alum treatment may require periodic sediment removal from the sediment basin or ponds in order to maintain normal functions.

**NOTES**

1. There are four types of aluminum coagulants – Aluminum Sulfate (ALUM), Aluminum Chloride, Poly Aluminum Hydroxychloride and Alum/Polymer Blends (Floc Logs).
2. The use of alum in sediment control and treatment within an erosion and sediment control plan will require the use of a sediment pond or sediment basin. The alum precipitate formed during coagulation of runoff from the erosion-related activities can be allowed to settle in receiving water bodies or collected in sediment basins.
3. In a typical treatment system, alum is injected into the flow on a flow-proportioned basis so that the same dose of alum is added regardless of the flow rate. A variable speed chemical metering pump is typically used as the injection pump. If the initial laboratory testing indicates that the addition of alum to the target runoff flow will reduce pH levels to undesirable levels, a buffering agent, such as sodium aluminate ( $Na_2Al_2O_4$ ) or sodium hydroxide ( $NaOH$ ) can be injected along with the alum to maintain desired pH levels. A separate metering system and storage tank will be necessary for the buffering agent.
4. Once alum has been identified as an option for the project, extensive laboratory testing must be performed to verify the feasibility of alum treatment and to establish process design parameters. The feasibility of alum treatment for a particular construction activity related runoff stream is typically evaluated in a series of laboratory jar tests conducted on representative runoff samples collected from the project watershed area. Laboratory testing is an essential part of the evaluation process necessary to determine design, maintenance, and operational parameters such as the optimum coagulant dose required to achieve the desired water quality goals, chemical pumping rates and pump sizes, the need for additional chemicals to buffer receiving water pH, post-treatment water quality characteristics, floc formation and settling characteristics, floc accumulation, annual chemical costs and storage requirements, ecological effects, and maintenance procedures. In addition to determining the optimum coagulant dose, jar tests can also be used to determine floc strength and stability, required mixing intensity and duration, and determine design criteria for settling basins.
5. Since  $Al^{+3}$  can be a potentially toxic species, floc formation should be complete prior to discharging the treated runoff into the receiving waterbody (Harper, 1990).  $Al^{+3}$  is virtually removed from the water column in 45-60 seconds after alum addition. Therefore, alum injection locations should be carefully selected to allow a minimum of 45-60 seconds of travel time after alum addition prior to reaching the receiving waterbody.

**DUAL POLYMER SYSTEMS**

Passive System with Pretreatment Sediment Pond Utilizing a Loose Material Dual Polymer System with Matting and Wattles

**WHAT IS ITS PURPOSE?**

To clean construction storm water from a pond using a passive system prior to discharging into a regulated water body

**WHERE AND HOW IS IT COMMONLY USED? (SEE FIGURE DPS-1)**

- On a stream of construction run off to treat the water prior to discharge
- Sedimentation pond utilizes natural gravitation settling. Polymer enhancement and outlet flow control allow for higher performance over gravitational settling alone.

**WHEN SHOULD IT BE INSTALLED?**

- Before construction activities begin
- While construction activities are occurring
- To treat water when larger amounts of sediment loads are present
- As a pre-treatment for secondary treatment
- When discharging into a non-high quality water body

**WHEN SHOULD IT NOT BE INSTALLED?**

- When precise dosing of treatment chemicals is required
- When discharging into a high quality water body

**WHAT NEEDS TO BE INSPECTED?**

- Is there excessive sediment loading in the pond?
- Is the polymer material in good condition?
- What is the condition of the matting and wattles?
- Is the water exiting the system of sufficient clarity?
- Does the residual water test show any remaining polymer in the effluent water?

**WHAT MAINTENANCE ACTIVITIES CAN BE EXPECTED?**

- Removal of sediment from pretreatment pond
- Addition of polymer when necessary
- Cleaning or replacement of matting and/or wattles

**NOTES**

- Polymers in general should not be directly released into civic storm water systems or natural watercourses.
- Discharging water through vegetated areas or additional BMP's can further reduce turbidity.
- Filtrate can be collected for secondary treatment (optional).
- Biopolymers will completely degrade with enzymatic action.
- Dose rate of chemicals is dependent on flow rate and volume of water

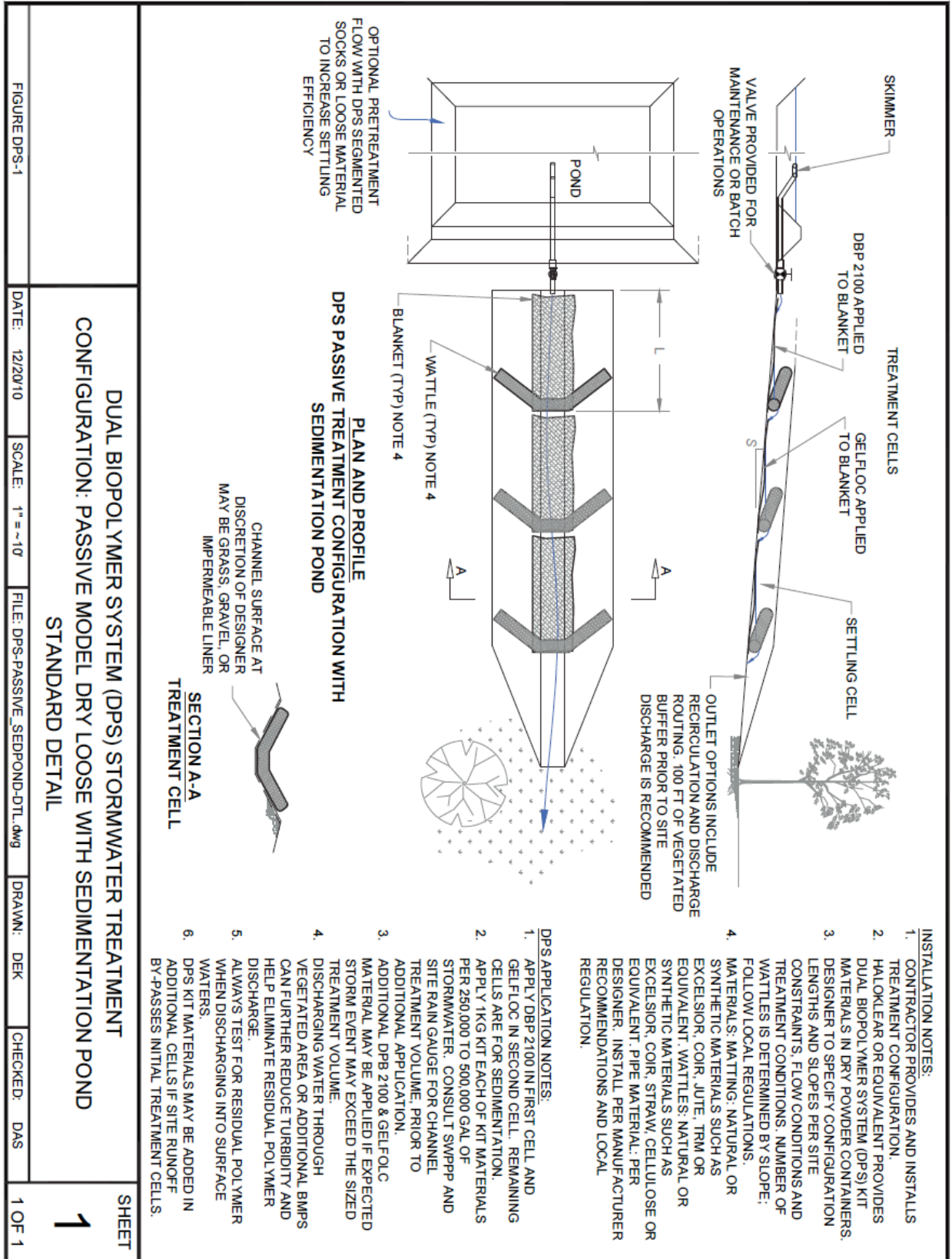

Figure AIII-30: Dual Biopolymer (DPS): Passive Dry use with Sedimentation Pond.

Passive Treatment of Turbid Water Utilizing a Dual Polymer System with Segmented Socks In Corrugated Pipe

**WHAT IS ITS PURPOSE?**

To clean construction storm water from a pond using a passive system prior to discharge into a regulated water body.

**WHERE AND HOW IS IT COMMONLY USED? (SEE FIGURE DPS-9)**

- On a stream of construction run off to treat the water prior to discharge

**WHEN SHOULD IT BE INSTALLED?**

- Before construction activities begin
- While construction activities are occurring
- To treat water stored on site
- After project completion to clean dirty water stored on site
- As pre-treatment for secondary treatment
- When discharging into a non-high quality water body

**WHEN SHOULD IT NOT BE INSTALLED?**

- When precise dosing of treatment chemicals is required
- When discharging into a high quality water body

**WHAT NEEDS TO BE INSPECTED?**

- Are the polymer socks in good condition?
- Are wattles still correctly installed or excessively blinded?
- Is the water exiting the system of sufficient clarity?
- Does the residual water test show any remaining polymer in the effluent water?

**WHAT MAINTENANCE ACTIVITIES CAN BE EXPECTED?**

- Changing of polymer socks
- Cleaning or replacement of wattles

***NOTES***

- Polymers in general should not be directly released into civic storm water systems or natural watercourses.
- Discharging water through vegetated areas or additional BMP's can further reduce turbidity.
- Biopolymers will completely degrade with enzymatic action.
- Dose rate of chemical is dependent on flow rate and volume of water. See approximate flow/dose table on attached drawing.

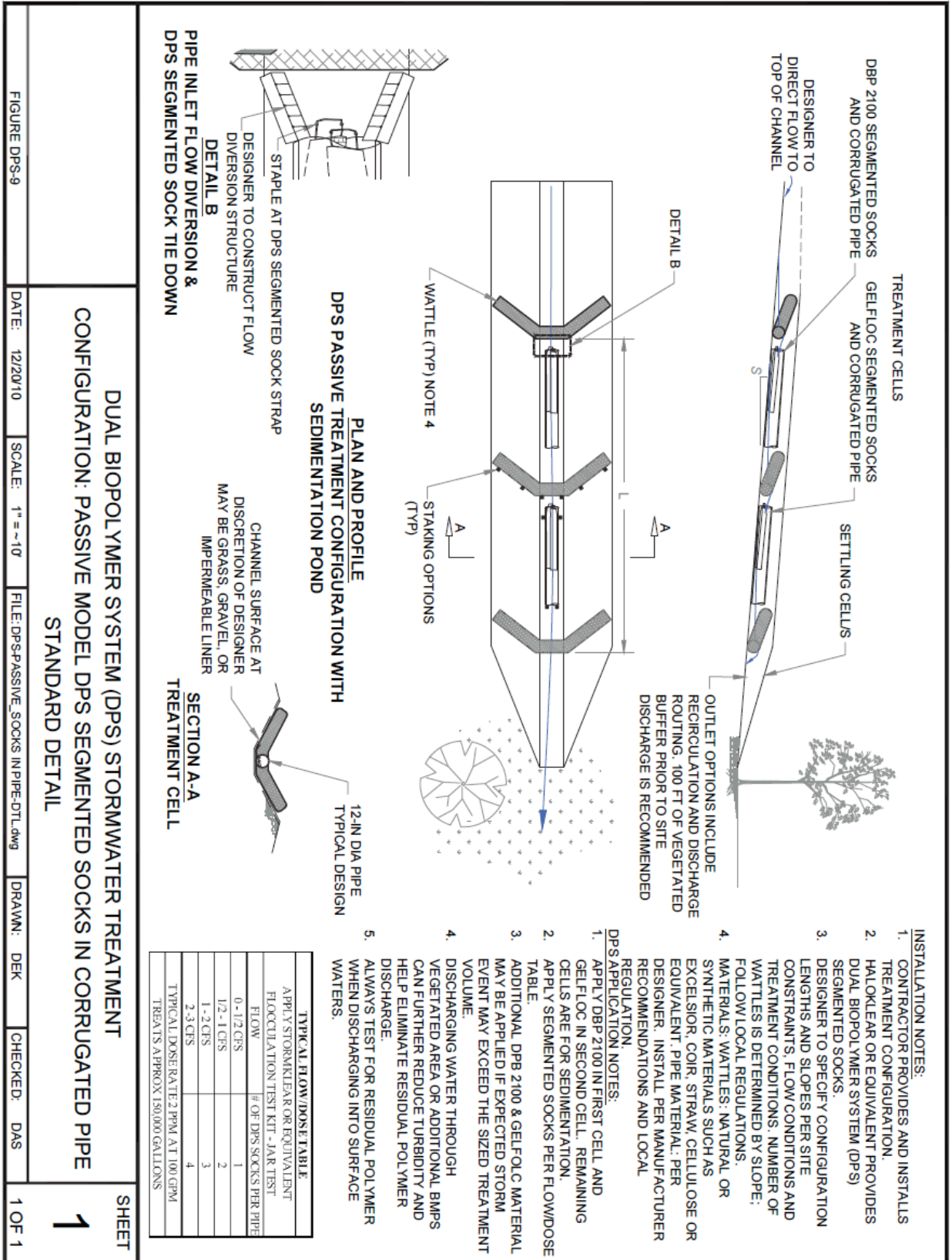

Figure AIII-32: Dual Biopolymer (DPS): Segmented Socks in Corrugated Pipe.



Passive Treatment of Turbid Water Utilizing a Dual Polymer System with Segmented Socks and Pipe on a Slope Drain

**WHAT IS ITS PURPOSE?**

To clean construction storm water prior to discharge into a regulated water body

**WHERE AND HOW IS IT COMMONLY USED? (SEE FIGURE DPS-4)**

- On a stream of construction run off to treat the water prior to discharge
- To convey and treat turbid water using site slope without creating further erosion

**WHEN SHOULD IT BE INSTALLED?**

- Before construction activities begin
- While construction activities are occurring
- To treat water stored on site
- As enhancement to typical slope drain application
- As pre-treatment for secondary treatment
- When discharging into a non-high quality water body

**WHEN SHOULD IT NOT BE INSTALLED?**

- When precise dosing of treatment chemicals is required
- When a slope to create proper flow is not available

**WHAT NEEDS TO BE INSPECTED?**

- Are the polymer socks in good condition?
- Is the effluent water from the pipe of sufficient clarity?
- Does the residual water test show any remaining polymer in the effluent water?

**WHAT MAINTENANCE ACTIVITIES CAN BE EXPECTED?**

- Changing of polymer socks

***NOTES***

- Polymers in general should not be directly released into civic storm water systems or natural watercourses.
- Discharging water through vegetated areas or additional BMP's can further reduce turbidity.
- Filtrate can be collected for secondary treatment (optional).
- Biopolymers will completely degrade with enzymatic action.
- Dose rate of chemical is dependent on flow rate and volume of water. See approximate flow/dose table on attached drawing.

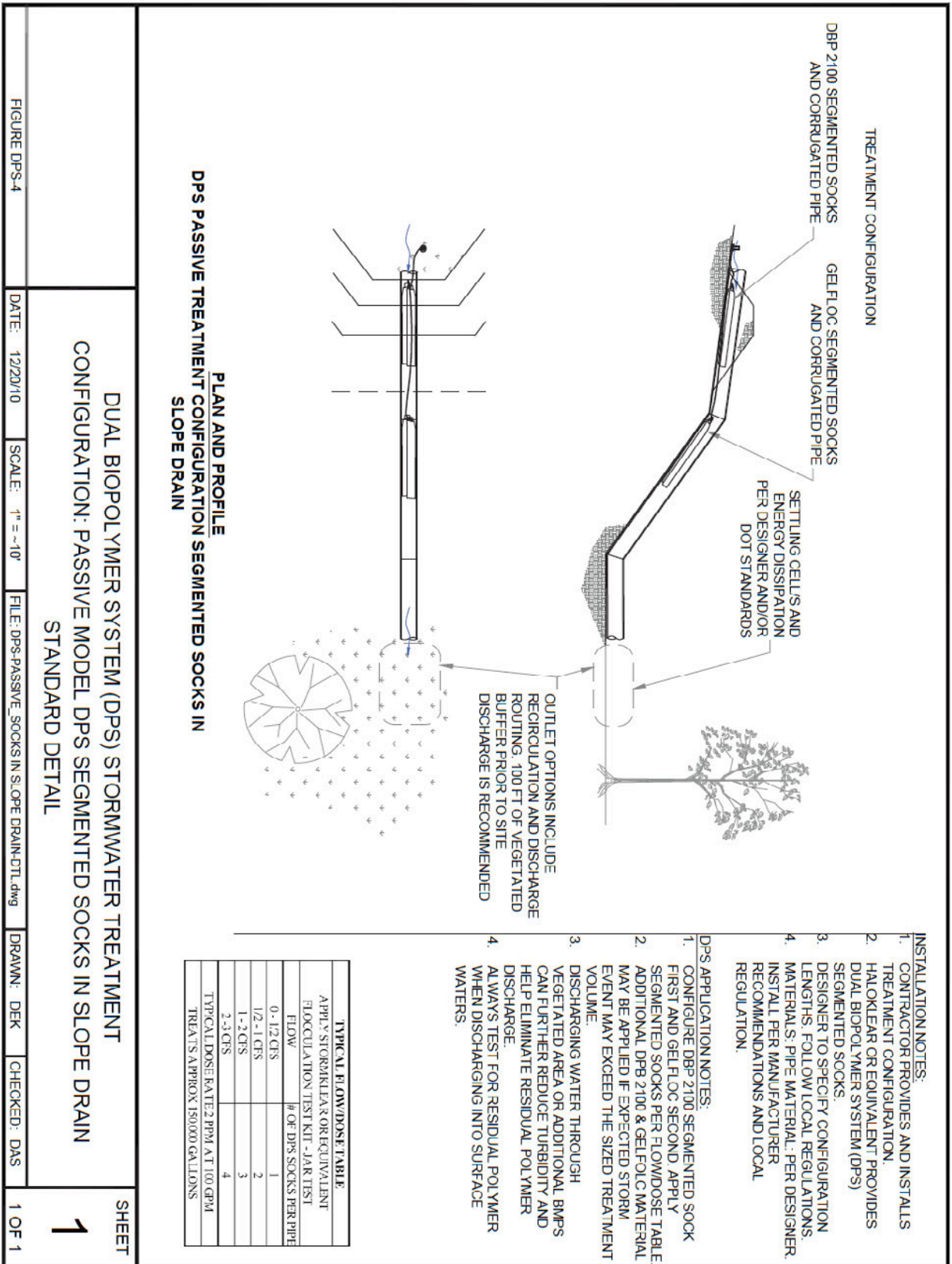

FIGURE DPS-4

DATE: 12/20/10

SCALE: 1" = -10'

FILE: DPS-PASSIVE SOCKS IN SLOPE DRAIN-DTL.dwg

DRAWN: DEK

CHECKED: DAS

1 OF 1

DUAL BIOPOLYMER SYSTEM (DPS) STORMWATER TREATMENT CONFIGURATION: PASSIVE MODEL DPS SEGMENTED SOCKS IN SLOPE DRAIN STANDARD DETAIL

SHEET

1

## Semi-Passive Treatment of Turbid Water Utilizing a Dual Polymer System and Dewatering Bags

### **WHAT IS ITS PURPOSE?**

To clean construction storm water from a pond using a semi-passive system prior to discharge into a regulated water body

### **WHERE AND HOW IS IT COMMONLY USED? (SEE FIGURE DPS-6)**

- On a stream of construction run off to treat the water prior to discharge

### **WHEN SHOULD IT BE INSTALLED?**

- Before construction activities begin
- While construction activities are occurring
- To treat water stored on site
- To treat water when larger amounts of sediment load are present
- After project completion to clean dirty water stored on site
- When discharging into a non-high quality water body
- When high sediment content in influent water
- When space is limited

### **WHEN SHOULD IT NOT BE INSTALLED?**

- When no method of pumping water is available
- When precise dosing of treatment chemicals is required
- When discharging into a high quality water body

### **WHAT NEEDS TO BE INSPECTED?**

- Is there excessive sediment loading in the pond?
- Are the polymer socks in good condition?
- What is the condition of the dewatering bags?
- Is the effluent water from the system of sufficient clarity?
- Does the residual water test show any remaining polymer in the effluent water?

### **WHAT MAINTENANCE ACTIVITIES CAN BE EXPECTED?**

- Clean sediment out of feed pond
- Check operation of water feed pump
- Changing of polymer socks
- Changing of dewatering bag

### **NOTES**

- Polymers in general should not be directly released into civic stormwater systems or natural watercourses.
- Discharging water through vegetated areas or additional BMP's can further reduce turbidity.
- Dewatering bags should be placed on rock, geotextile fabric or vegetative surfaces.
- Biopolymers will completely degrade with enzymatic action.
- See table on drawing for flow/dose rates of polymer.

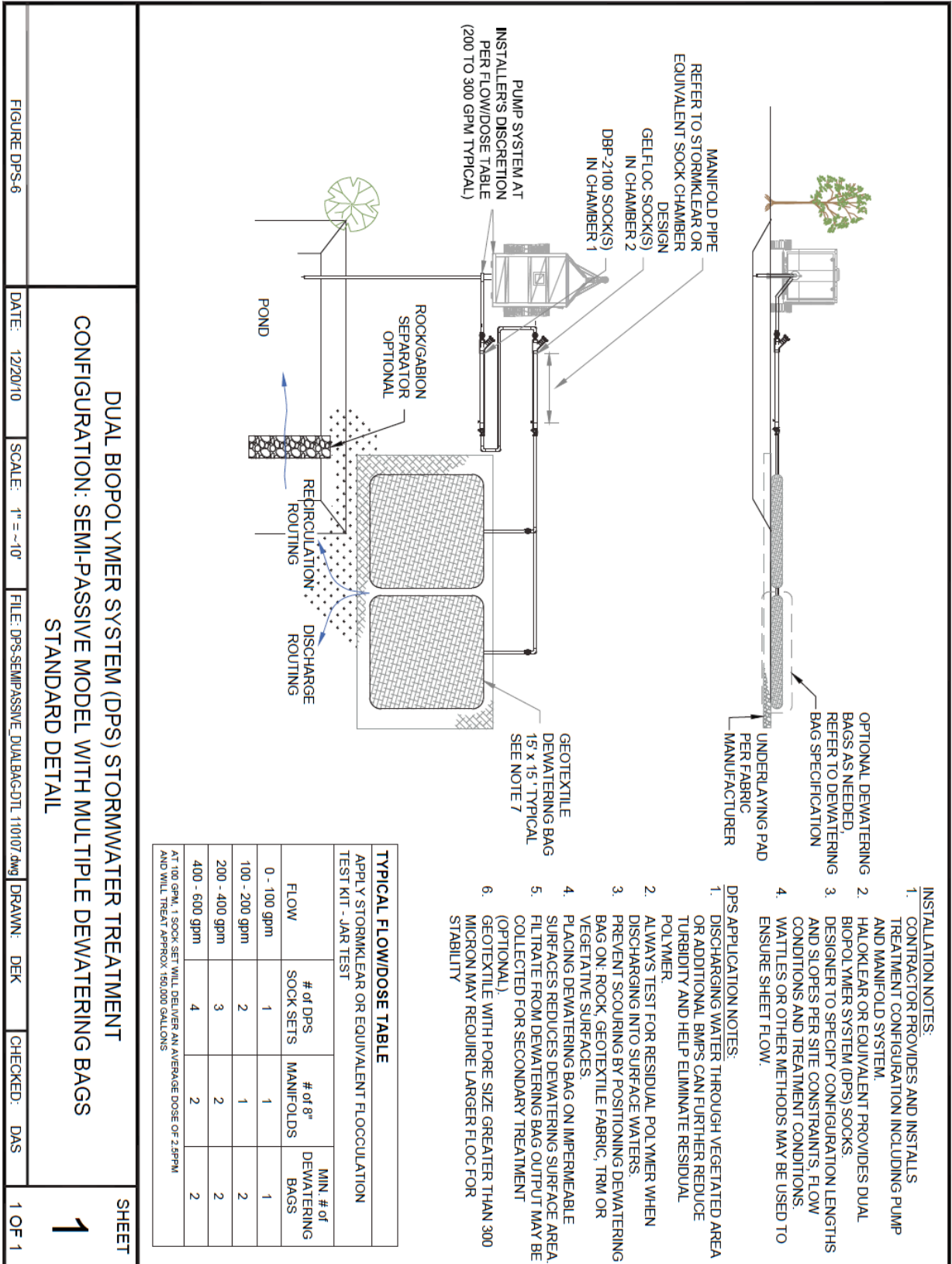

Figure AIII-34: Dual Biopolymer (DPS): Multiple Dewatering Bags.

Passive Treatment of Turbid Water Utilizing a Loose Material Dual Polymer System with Matting and Wattles

**WHAT IS ITS PURPOSE?**

To clean construction storm water from a pond using a passive system prior to discharge into a regulated water body.

**WHERE AND HOW IS IT COMMONLY USED? (SEE FIGURE DPS-10)**

- On a stream of construction run off to treat the water prior to discharge

**WHEN SHOULD IT BE INSTALLED?**

- Before construction activities begin
- While construction activities are occurring
- To treat water stored on site
- After project completion to clean dirty water stored on site
- As pre-treatment for secondary treatment
- When discharging into a non-high quality water body

**WHEN SHOULD IT NOT BE INSTALLED?**

- When precise dosing of treatment chemicals is required
- When discharging into a high quality water body

**WHAT NEEDS TO BE INSPECTED?**

- Is the polymer material in good condition?
- What is the condition of the matting and wattles?
- Is the water exiting the system of sufficient clarity?
- Does the residual water test show any remaining polymer in the effluent water?

**WHAT MAINTENANCE ACTIVITIES CAN BE EXPECTED?**

- Addition of polymer when/if necessary
- Cleaning or replacement of matting and/or wattles

**NOTES**

- Polymers in general should not be directly released into civic storm water systems or natural watercourses.
- Discharging water through vegetated areas or additional BMP's can further reduce turbidity.
- Biopolymers will completely degrade with enzymatic action.
- Dose rate of chemical is dependent on flow rate and volume of water

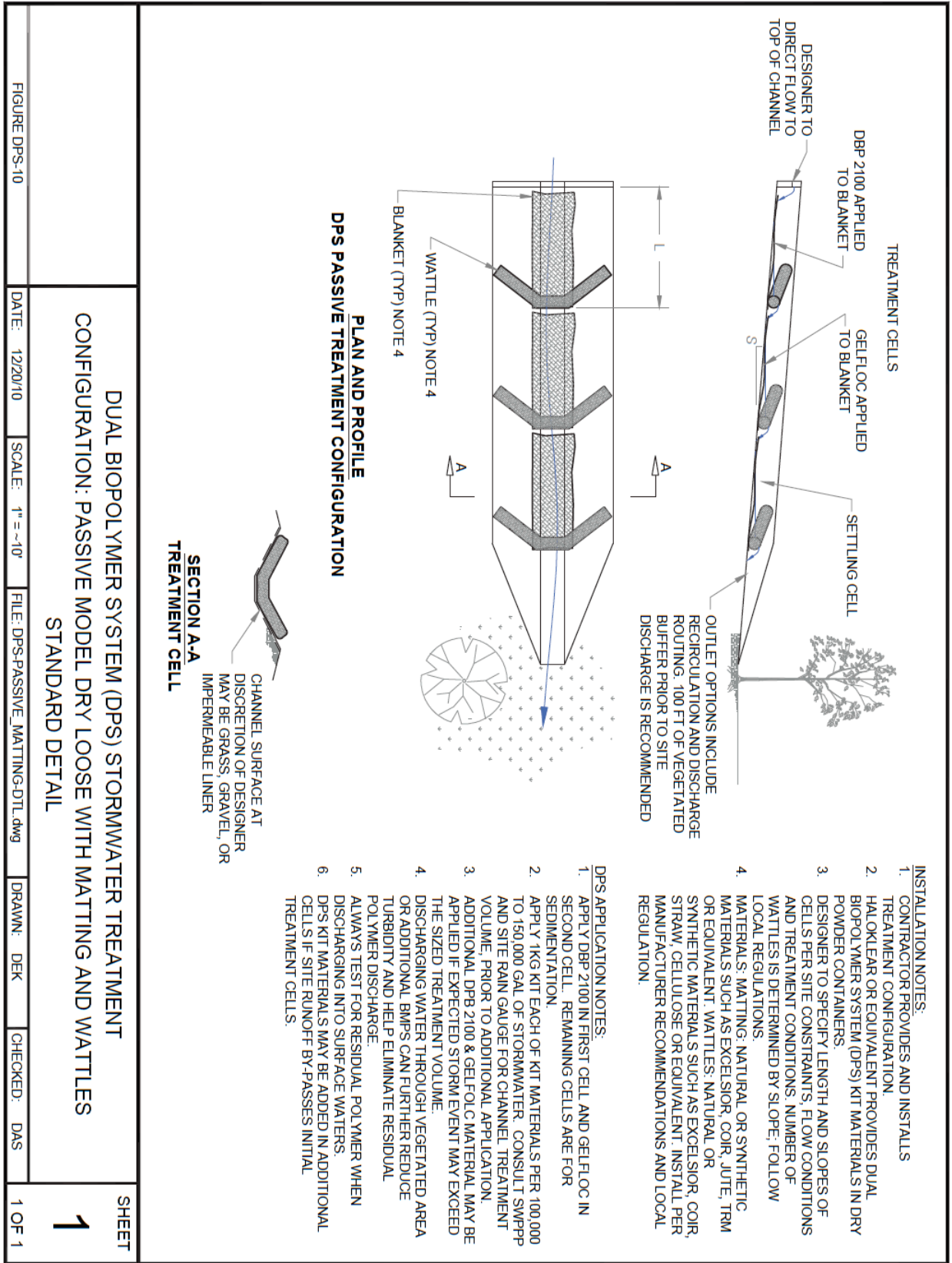

Figure AIII-35: Dual Biopolymer (DPS): with Matting and Wattles.

Semi-Passive Treatment of Turbid Water Utilizing a Dual Polymer System, Settling Tank and Wattles

**WHAT IS ITS PURPOSE?**

To clean construction storm water from a pond using a semi-passive system prior to discharging into a regulated and/or high quality water body

**WHERE AND HOW IS IT COMMONLY USED? (SEE FIGURE DPS-3)**

- On a stream of construction run off to treat the water prior to discharge

**WHEN SHOULD IT BE INSTALLED?**

- Before construction activities begin
- While construction activities are occurring
- To treat water stored on site
- To treat water when larger amounts of sediment load are present
- After project completion to clean dirty water stored on site
- For discharge into high quality water bodies

**WHEN SHOULD IT NOT BE INSTALLED?**

- When no method of pumping water is available
- When precise dosing of treatment chemicals is required

**WHAT NEEDS TO BE INSPECTED?**

- Is there excessive sediment loading in the collection pond?
- Is the pump operating correctly?
- Are the polymer socks in good condition?
- Are there excessive solids in the settling tank?
- Are the wattles in good condition?
- Is the effluent water from the system of sufficient clarity?
- Does the residual water test show any remaining polymer in the effluent water?

**WHAT MAINTENANCE ACTIVITIES CAN BE EXPECTED?**

- Clean out solids from feed pond
- Routine maintenance of water feed pump
- Changing of polymer socks
- Remove solids from tank
- Changing or cleaning of wattles

**NOTES**

- Polymers in general should not be directly released into civic storm water systems or natural watercourses.
- Discharging water through vegetated areas or additional BMP's can further reduce turbidity.
- Biopolymers will completely degrade with enzymatic action.
- See table on drawing for flow/dose rates of polymer.

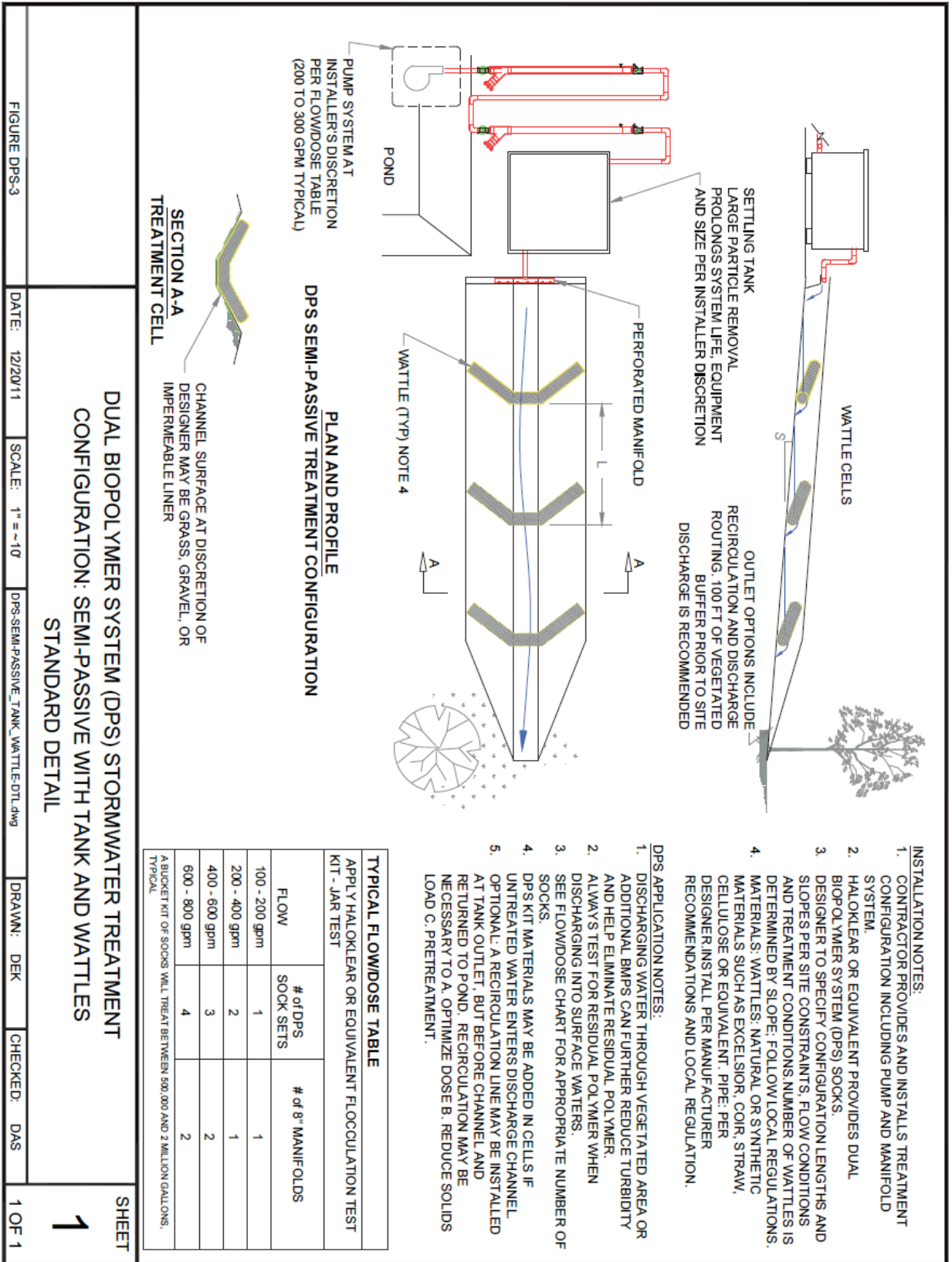

Figure AIII-36: Dual Biopolymer (DPS): with Tank and Wattles.



Semi-Passive Treatment of Turbid Water Utilizing a Dual Polymer System, Settling Tank and Dewatering Bags

**WHAT IS ITS PURPOSE?**

To clean construction storm water from a pond using a semi-passive system prior to discharging into a regulated and/or high quality water body

**WHERE AND HOW IS IT COMMONLY USED? (SEE FIGURE DPS-5)**

- On a stream of construction run off to treat the water prior to discharge

**WHEN SHOULD IT BE INSTALLED?**

- Before construction activities begin
- While construction activities are occurring
- To treat water stored on site
- To treat water when larger amounts of sediment load are present
- After project completion to clean dirty water stored on site
- When discharging into a high quality water body

**WHEN SHOULD IT NOT BE INSTALLED?**

- When no method of pumping water is available
- When precise dosing of treatment chemicals is required

**WHAT NEEDS TO BE INSPECTED?**

- Are the polymer socks in good condition?
- Are there excessive solids in the settling tank?
- What is the condition of the dewatering bags?
- Is the water exiting the system of sufficient clarity?
- Does the residual water test show any remaining polymer in the effluent water?

**WHAT MAINTENANCE ACTIVITIES CAN BE EXPECTED?**

- Routine maintenance of water feed pump
- Changing of polymer socks
- Removing of solids from settling tank
- Changing of dewatering bag

**NOTES**

- Polymers in general should not be directly released into civic storm water systems or natural watercourses.
- Discharging water through vegetated areas or additional BMP's can further reduce turbidity.
- Biopolymers will completely degrade with enzymatic action.
- See table on drawing for flow/dose rates of polymer.

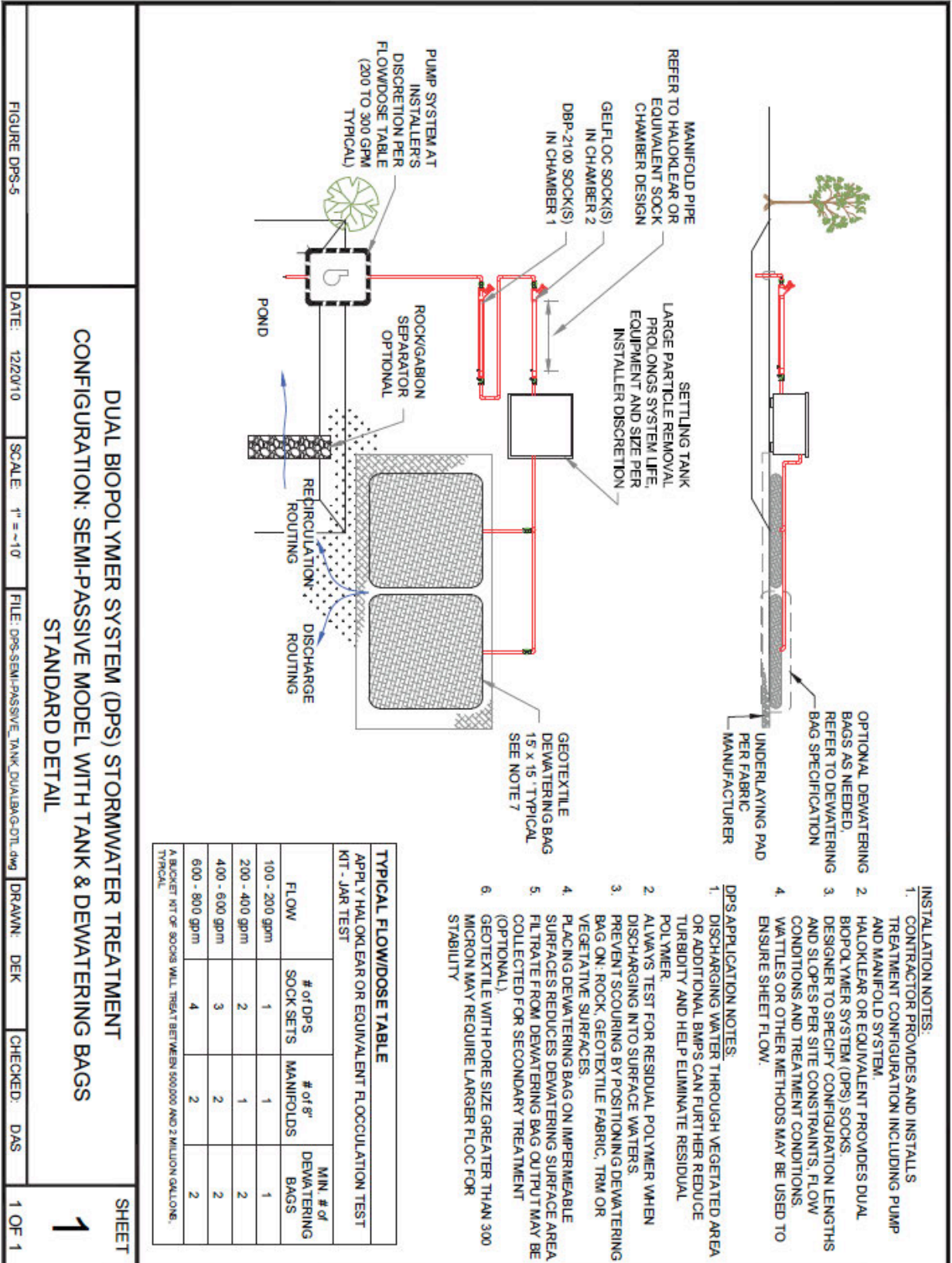

FIGURE DPS-5

DATE: 12/20/10

SCALE: 1" = -10'

FILE: DPS-SEMI-PASSIVE\_TANK\_DUALBAG-DTL.dwg

DRAWN: DEK

CHECKED: DAS

1 OF 1

DUAL BIOPOLYMER SYSTEM (DPS) STORMWATER TREATMENT  
 CONFIGURATION: SEMI-PASSIVE MODEL WITH TANK & DEWATERING BAGS  
 STANDARD DETAIL

SHEET  
 1

Semi-Passive Treatment of Turbid Water Utilizing a Dual Polymer System, Tank,  
Dewatering Bag and Wattle Channel

**WHAT IS ITS PURPOSE?**

To clean construction storm water from a pond using a passive system prior to discharge into a regulated water body.

**WHERE AND HOW IS IT COMMONLY USED? (SEE FIGURE DPS-7)**

- On a stream of construction run off to treat the water prior to discharge

**WHEN SHOULD IT BE INSTALLED?**

- Before construction activities begin
- While construction activities are occurring
- To treat water stored on site
- To treat water when very large amounts of sediment load are present
- After project completion to clean dirty water stored on site
- For discharge into high quality water bodies

**WHEN SHOULD IT NOT BE INSTALLED?**

- When no method of pumping water is available
- When precise dosing of treatment chemicals is required

**WHAT NEEDS TO BE INSPECTED?**

- Are the polymer socks in good condition?
- What is the amount of solids in settling tank?
- What is the amount of solids in dewatering bag?
- What is the condition of the wattles?
- Is the water exiting the system of sufficient clarity?
- Does the residual water test show any remaining polymer in the effluent water?

**WHAT MAINTENANCE ACTIVITIES CAN BE EXPECTED?**

- Routine maintenance of the water feed pump
- Changing of polymer socks
- Removal of solids from settling tanks
- Changing of dewatering bags

**NOTES**

- Polymers in general should not be directly released into civic storm water systems or natural watercourses.
- Discharging water through vegetated areas or additional BMP's can further reduce turbidity.
- Biopolymers will completely degrade with enzymatic action.
- See table on drawing for flow/dose rates of polymer.

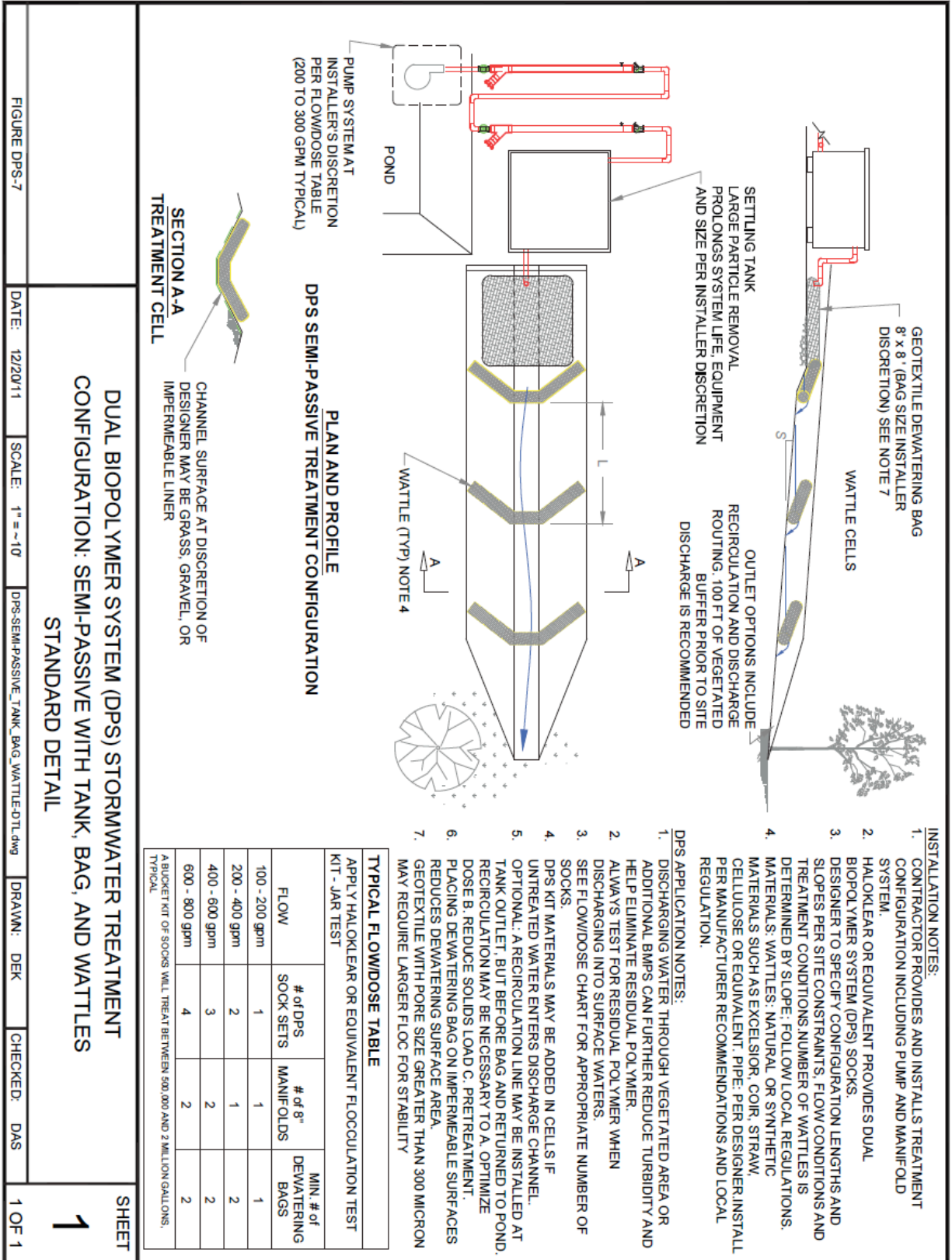

Figure AIII-38: Dual Biopolymer (DPS): with Tank, Bag and Wattles.

Active Treatment of Turbid Water Utilizing a Liquid Dual Polymer System with  
Pre-Filtration and Sand Filtration

**WHAT IS ITS PURPOSE?**

To clean construction storm water from a pond using an active system prior to discharge into a regulated and/or high quality water body.

**PLEASE NOTE: These systems are designed for site specifications.**

**WHERE AND HOW IS IT COMMONLY USED? (SEE FIGURE DPS-8)**

- On a stream of construction run off to treat the water prior to discharge

**WHEN SHOULD IT BE INSTALLED?**

- Before construction activities begin
- While construction activities are occurring
- To treat water stored on site
- To treat water when larger amounts of sediment load are present
- After project completion to treat dirty water stored on site
- In front of remediation equipment such as carbon filters, etc.
- When a very high quality effluent is required
- When precise dosing of treatment chemicals is required

**WHEN SHOULD IT NOT BE INSTALLED?**

- When power is not available
- If truck access to the area to service system is not possible

**WHAT NEEDS TO BE INSPECTED?**

- Is there excessive sediment loading in the storage structure?
- Are the chemical-feed pumps operating correctly?
- Do the chemical storage vessels have adequate product?
- Is the effluent water from the system of sufficient clarity?
- Does the water meet all effluent criteria?
- Does the residual water test show any remaining polymer in the effluent water?

**WHAT MAINTENANCE ACTIVITIES CAN BE EXPECTED?**

- Removal of sediment from the storage structure
- Maintaining operation of polymer feed pumps
- Changing of polymer storage vessels
- Maintenance of instrumentation
- Monitoring sand filter function to include changing of sand if needed.

**NOTES**

- Polymers in general should not be directly released into civic storm water systems or natural watercourses.
- Discharging water through vegetated areas or additional BMP's can further reduce turbidity.
- Filtrate can be collected for secondary treatment (optional).
- Biopolymers will completely degrade with enzymatic action.

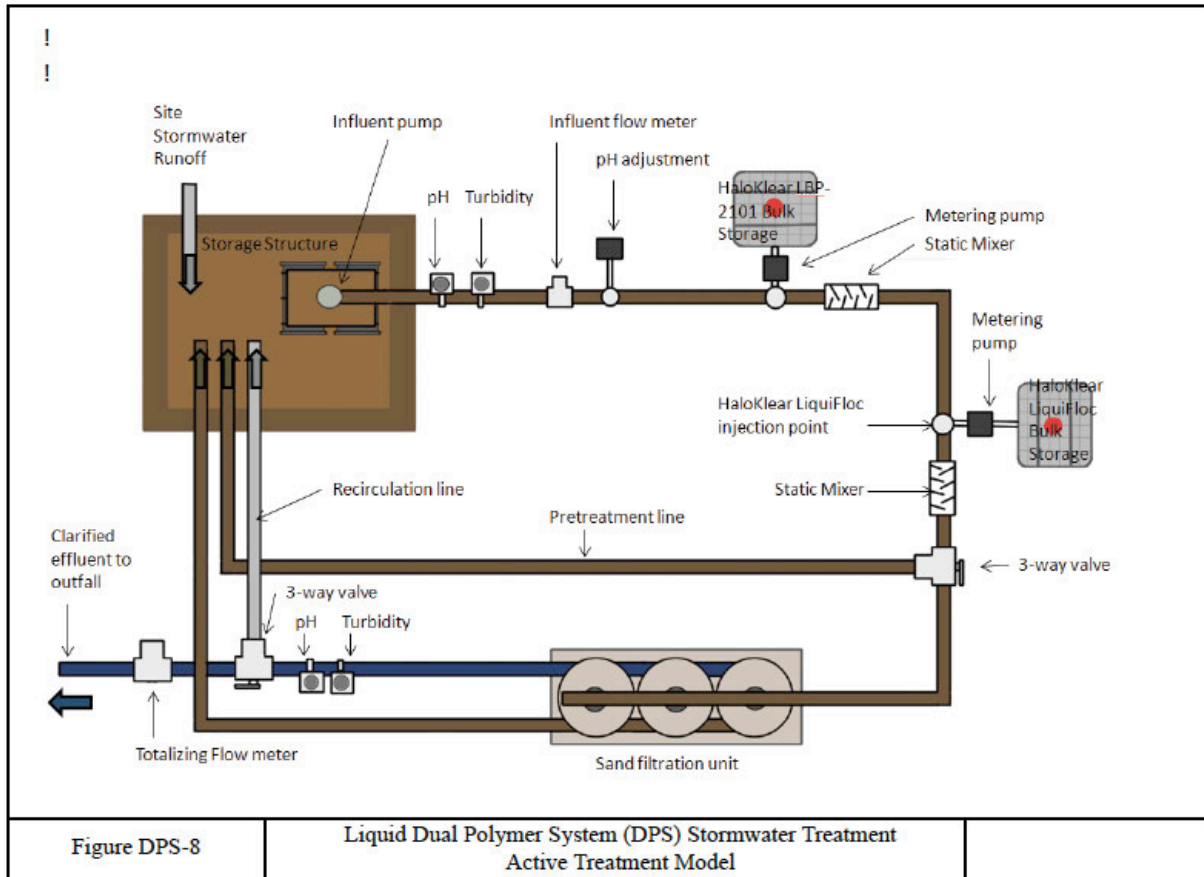

Figure AIII-39: Liquid Dual Biopolymer (DPS): Active Treatment Model.

Semi-Passive Treatment of Turbid Water Utilizing a Liquid Dual Polymer System and Dewatering Bags

**WHAT IS ITS PURPOSE?**

To clean construction stormwater from a pond using a passive system prior to discharge into a regulated and/or high quality water body

**WHERE AND HOW IS IT COMMONLY USED? (SEE FIGURE DPS-2)**

- On a stream of construction run off to treat the water prior to discharge

**WHEN SHOULD IT BE INSTALLED?**

- When a high quality effluent is required
- Before construction activities begin
- While construction activities are occurring
- To treat water stored on site
- To treat water when larger amounts of sediment load are present
- After project completion to clean dirty water stored on site

**WHEN SHOULD IT NOT BE INSTALLED?**

- When power is not available
- If truck access to the area to deliver chemicals is not possible

**WHAT NEEDS TO BE INSPECTED?**

- Is there excessive sediment loading in the pond?
- Are the chemical-feed pumps operating correctly?
- Polymer dose rate jar testing for dose optimization (see chart below)
- Is the effluent water from the system of sufficient clarity?

**WHAT MAINTENANCE ACTIVITIES CAN BE EXPECTED?**

- Removal of sediment from the feed pond
- Maintaining operation of polymer feed pumps
- Maintaining sufficient quantity of polymer Changing of dewatering bag

**NOTES**

- Polymers in general should not be directly released into civic stormwater systems or natural watercourses.
- Discharging water through vegetated areas or additional BMP's can further reduce turbidity. Filtrate can be collected for secondary treatment (optional).
- Dewatering bags should be placed on rock, geotextile fabric or vegetative surfaces.
- Biopolymers will completely degrade with enzymatic action.

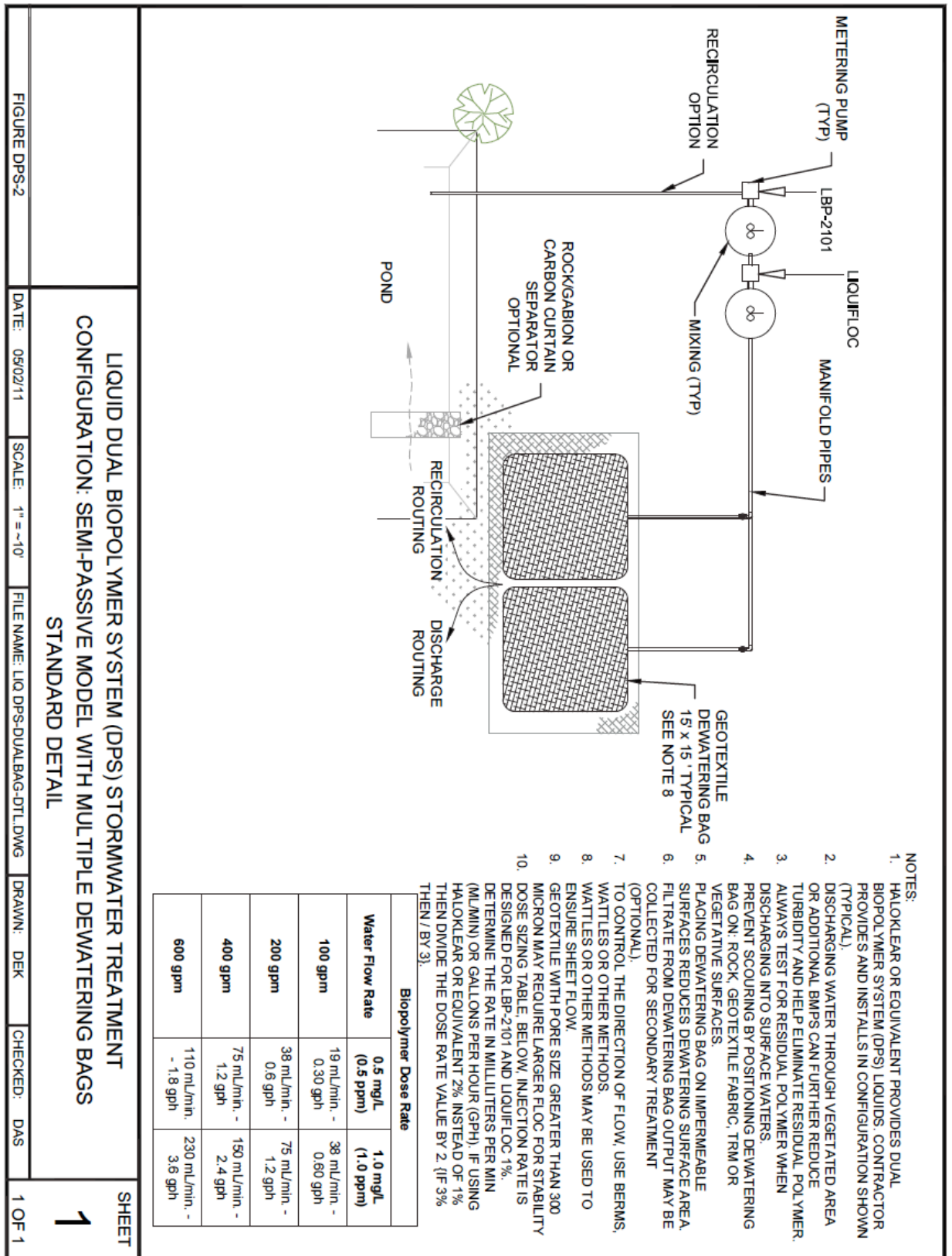

Figure AIII-40: Liquid Dual Biopolymer (DPS): with Multiple Dewatering Bags.



## REFERENCES

1. Alabama Handbook, Practices for Erosion and Sediment Control, Chapter 9 (1993), "Anionic Polyacrylamide Erosion Control (PAM)"
2. Applied Polymer Systems, Inc., Acute and Chronic Toxicity Testing, MACTEC Engineering, 2003.
3. Applied Polymer Systems, Inc., Case History Data Base, Hydrograss Technologies Case File, South Hadley, MA Spring 2006a.
4. Applied Polymer Systems, Inc., Case History Data Base, Hydrograss Technologies Case File, Greenbush Corridor, MA Spring 2006b.
5. Brezonik, P.L. (1984). "Trophic State Indices: Rationale for Multivariate Approaches." In Lake and Reservoir Management, pp. 427-430, EPA-440/5-84-001.
6. Carter, O. C., Jr., Schiener, B.J. "Removal of Toxic Metals From and Industrial Wastewater Using Flocculants. Fluid/Particle Separation Journal. Vol. 4, No. 4. December 1991.
7. Chang, S.C., and Jackson, J.L. (1957). A Fractionation of Soil Phosphorus. *Soil Sci.*, 84, 133-144.
8. Chastain, J. P., Matias B. Vanotti, M. M. Wingfield. "Effectiveness of Liquid-Solid Separation for Treatment of Slushed Dairy Manure: A Case Study." Tektran. December 2000. USDA: Agricultural Research Service. 29 Jan. 2004.
9. Cooke, G.D., and Kennedy, R.H. (1981). Precipitation and Inactivation of Phosphorus as a Lake Restoration Technique. EPA-600/3-81-012.
10. Erwin, L, "Theory of Laminar Mixing" *Polym. Eng. Sci.* 18, 1044 (1978)
11. Flanagan, D. and Canady, N. (2006). "Use of Polyacrylamide in Simulated Land Application of Lagoon Effluent: Part II: Nutrient Loss, Transactions of the ASABE, 49(5): 1371-1381.
12. Garrison, P.J., and Knauer, D.J. (1984). "Long-Term Evaluation of Three Alum Treated Lakes." In Lake and Reservoir Management, pp. 513-517. EPA-440/5-84-001.
13. Georgia Soil Water Conservation Commission, Manual for Erosion and Sedimentation Control in Georgia, Fifth Edition, 2000.
14. Gowdy, W., Hanna, J. and Iwinski, S.R., (2006). "Technological Solutions for Erosion Control and Water Clarification using Polyacrylamide (PAM) and PAM Blends." Remediation Technology Symposium, Banff, Alberta, October 2006.
15. Green, Steven V and Stott D.E., Polyacrylamide: "A Review of the Use, Effectiveness, and Cost of a Soil Erosion Control Amendment", Selected papers from the 10th International Soil Conservation Organization Meeting held May 24-29, 1999 at Purdue University, Pages 384-389.
16. Harper, H.H. (December 1990). "Long-Term Performance Evaluation of the Alum Stormwater Treatment System at Lake Ella, Florida." Final Report submitted to the Florida Department of Environmental Regulation, Project WM339.
17. Iwinski, Steven R. "Erosion Control, Acid Rock Drainage Mitigation and Prevention Using PAM, a Co-Polymer of Polyacrylamide." Admiralty Island National Monument. Juneau, Alaska. May 1996.
18. Iwinski, Steven R., Stein, Ethan A., Condon, Peter D. "The Effects of Polymer on Metal Leaching in ARD Potential Rock." Admiralty Island National Monument. Juneau, Alaska. 29 Aug. 1996.
19. Iwinski, Steven R. "Treatment of Mine and Mill Water." Alaska Miners Association. 1995. Conference Juneau: Abstracts of Professional Papers. No. 18. Pg. 47. April 19-21. 1995.
20. Jernelov, A. (1970). Phosphate Reduction in Lakes by Precipitation with Aluminum Sulfate. 5th

International Water Pollution Research Conference. New York: Pergamon Press.

21. McLaughlin, R.A., Hayes, S.A., and Bartholomew, N., “Innovations (Old and New) for Improving Erosion, Sediment, and Turbidity Control”, 2003 International Erosion Control Association Meeting, Las Vegas, NV.
22. Orme S., and Kegley S., PAN Pesticide Data Base, Pesticide Action Network, North America, San Francisco, CA, 2004.
23. Price and Company, Inc., (Case File) Big Rock Point Restoration, Charlevoix, MI, Nov. 4, 2004.
24. Price and Company, Inc., (Case File) Oak Park Washtenaw Heights, Ann Arbor, MI, Feb. 3, 2005.
25. Sojka, R. E., Lentz, R. D., Bjornberg, D. J., Aase, J. K. “The PAMphlet.” Northwest Irrigation and Soils Research Lab. USDA: Agricultural Research Service. 26 Aug. 2003.
26. Virginia Erosion & Sediment Control Handbook, E&SC Technical Bulletin #2, “Application of Anionic Polyacrylamide for Soil Stabilization and Stormwater Management”
27. Yoon, Tae H., Hichung Moon, Yeong J. Park, Kyoung K. Pask. “Investigation of Metal Binding Sites on Soil Fulvic Acid Using Eu(III) Luminescence Spectroscopy.” Environmental Science Technology. 1994. Vol. 28. No. 12. Pg. 2139 – 2146. 1994.

**APPENDIX IV**  
**INSPECTION AND SCHEDULING FORMS**

Site Name: \_\_\_\_\_ Date of Evaluation: \_\_\_\_\_ Page \_\_\_\_ of \_\_\_\_

Completed by: \_\_\_\_\_ Existing Weather Conditions: \_\_\_\_\_

Rainfall Event	Date Began	Duration (Hours)	Amount (Inches)	Rainfall Event	Date Began	Duration (Hours)	Amount (Inches)	Rainfall Event	Date Began	Duration (Hours)	Amount (Inches)
1				2				3			

SWPPP Information	YES	NO	N/A	Comments
	1. For a nonlinear project, is a sign or other notice: a) Posted conspicuously near the main entrance of the construction site or if not feasible, b) Posted in a local public building such as the town hall or public library For linear projects, is a sign or other notice posted at a publicly accessible location near the active construction project? √ Is a copy of the permit attached? √ Is the current location of the SWPPP and names and telephone numbers of a contact person for scheduling viewing times shown?			
2. Does a copy of the SWPPP and accompanying sediment and erosion control drawings exist on the construction site? √ Is the discharge permit on the construction site? √ Is the discharge permit acknowledgement letter on the construction site? √ Are the SWPPP and/or accompanying sediment and erosion control drawings updated and documented?				
3. Do inspection records exist on the construction sites? √ Has the frequency of inspections occurred as specified in the SWPPP? √ Have all previous inspection items been addressed and documented within seven (7) calendar days after an inspection?				
4. Do climatic records exist since the last inspection?				
BMP/Housekeeping Information				
5. Are offsite flows entering the construction site?				If yes, see attached detail report
6. Is there evidence of, or the potential for, increased pollutant (e.g., sediment, fuel, concrete waste, portable toilet waste, etc.) loading to enter the storm water conveyance system due to lack of maintenance or improper BMP installation?				If yes, see attached detail report
7. Do installation, repair and/or maintenance of <u>sediment</u> control BMPs need to occur?				If yes, see attached detail report
8. Do installation, repair and/or maintenance of <u>erosion</u> control BMPs need to occur?				If yes, see attached detail report
9. Is there evidence of sediment discharging <u>off</u> the construction site and onto downstream locations?				If yes, see attached detail report
10. Are vehicles tracking sediment <u>off</u> the construction site?				If yes, see attached detail report
11. If applicable, is soil, construction material, landscaping items, or other debris evident on the streets?				If yes, see attached detail report
12. Do locations exist where consideration of installing additional BMPs not found in the SWPPP should occur?				If yes, see attached detail report
13. Do locations exist where consideration of removing existing BMPs identified and shown in the SWPPP can occur?				If yes, see attached detail report
14. Does your site evaluation indicate a need to possibly update and document the SWPPP report and accompanying sediment and erosion control drawings within the next seven (7) days?				

Site Name: \_\_\_\_\_ Date of Evaluation: \_\_\_\_\_ Page \_\_\_\_ of \_\_\_\_

Completed by: \_\_\_\_\_

Detail Report: Identify the problem and its location. If appropriate, describe (in general terms) what needs to be done. However, only if qualified (e.g., you are a designer) should you be mandating specific BMPs to install.	Date done (with initials)
1.	
2.	
3.	
4.	
5.	
6.	
7.	
8.	
9.	
10.	

I certify under penalty of law that this document and all attachments were prepared under my direction or supervision in accordance with a system designed to assure that qualified personnel properly gathered and evaluated the information submitted. Based on my inquiry of the person or persons who manage the system, or those persons directly responsible for gathering the information, the information submitted is, to the best of my knowledge and belief, true, accurate, and complete. I am aware that there are significant penalties for submitting false information, including the possibility of fine and imprisonment for knowing violations.

\_\_\_\_\_  
 (Print Name) (Signature) Date:

Title/Qualification of Inspector: \_\_\_\_\_

To be signed by a corporate officer **ONLY IF NO INCIDENTS** of non-compliance are found: I certify the construction site is in compliance with the SWPPP and any accompanying discharge permit(s) requirements:

\_\_\_\_\_  
 (Print Name) (Signature) Date:

PROJECT: \_\_\_\_\_ DATE: \_\_\_\_\_  
 SCHEDULE FOR \_\_\_\_\_ AND \_\_\_\_\_  
 COMPLETED BY: \_\_\_\_\_

Indicate by use of a bar line or symbols when sediment and erosion control measures will be installed or when other activities will be implemented. Use additional forms as necessary.

MONTH																				
WEEK	1	2	3	4	5	1	2	3	4	5	1	2	3	4	5	1	2	3	4	5
OVERLOT GRADING																				
CONSTRUCTION ACTIVITIES																				
RAINFALL CONTROL																				
STRUCTURAL:																				
Sediment Containment System																				
Continuous Berm Barriers																				
Bale Barriers																				
Silt Fence Barriers																				
Rock Barriers																				
Inlet/Curb Barriers																				
Vehicle Tracking Pad																				
Terracing																				
NON-STRUCTURAL:																				
Permanent Seed Planting																				
Temporary Seed Planting																				
Mulching/Sealant																				
Sod Installation																				
Hillside RECPs																				
Channels RECPs																				
Asphalt/Concrete Paving																				
WIND CONTROL																				
Soil Roughening																				
Perimeter Barrier																				
Additional Barriers																				
Vegetative Methods																				
Soil Binders																				
WEED CONTROL																				
INSPECTION/MAINTENANCE																				

Comments:

PROJECT: \_\_\_\_\_ DATE: \_\_\_\_\_

COMPLETED BY: \_\_\_\_\_

SCHEDULE FOR \_\_\_\_\_ AND \_\_\_\_\_

Indicate by use of a bar line or symbols when sediment and erosion control measures will be installed or when other activities will be implemented. Use additional forms as necessary.

YEAR												
MONTH	1	2	3	4	5	6	7	8	9	10	11	12
OVERLOT GRADING												
CONSTRUCTION ACTIVITIES												
RAINFALL CONTROL												
STRUCTURAL:												
Sediment Containment System												
Continuous Berm Barriers												
Bale Barriers												
Silt Fence Barriers												
Rock Barriers												
Inlet/Curb Barriers												
Vehicle Tracking Pad												
Terracing												
NON-STRUCTURAL:												
Permanent Seed Planting												
Temporary Seed Planting												
Mulching/Sealant												
Sod Installation												
Hillside RECPs												
Channels RECPs												
Asphalt/Concrete Paving												
WIND CONTROL												
Soil Roughening												
Perimeter Barrier												
Additional Barriers												
Vegetative Methods												
Soil Sealant												
WEED CONTROL												
INSPECTION/MAINTENANCE												

**This page intentionally blank**



**APPENDIX V**  
**EXAMPLE PLANS AND DETAILS**

PROJECT NAME  
 SEDIMENT AND EROSION CONTROL PLAN  
 PROJECT NO. xxxxxxxx  
 TOWNSHIP, RANGE, SECTION NUMBER

USGS Quadrangle map here  
 illustrating site location

1/4 Section, Township, Range  
 Scale: 1" = 2000'

PRELIMINARY SCHEDULE

NO.	DATE	DESCRIPTION
1	10/15/12	PRELIMINARY SCHEDULE
2	10/15/12	PRELIMINARY SCHEDULE
3	10/15/12	PRELIMINARY SCHEDULE
4	10/15/12	PRELIMINARY SCHEDULE
5	10/15/12	PRELIMINARY SCHEDULE
6	10/15/12	PRELIMINARY SCHEDULE
7	10/15/12	PRELIMINARY SCHEDULE
8	10/15/12	PRELIMINARY SCHEDULE
9	10/15/12	PRELIMINARY SCHEDULE
10	10/15/12	PRELIMINARY SCHEDULE
11	10/15/12	PRELIMINARY SCHEDULE
12	10/15/12	PRELIMINARY SCHEDULE
13	10/15/12	PRELIMINARY SCHEDULE
14	10/15/12	PRELIMINARY SCHEDULE
15	10/15/12	PRELIMINARY SCHEDULE
16	10/15/12	PRELIMINARY SCHEDULE
17	10/15/12	PRELIMINARY SCHEDULE
18	10/15/12	PRELIMINARY SCHEDULE
19	10/15/12	PRELIMINARY SCHEDULE
20	10/15/12	PRELIMINARY SCHEDULE
21	10/15/12	PRELIMINARY SCHEDULE
22	10/15/12	PRELIMINARY SCHEDULE
23	10/15/12	PRELIMINARY SCHEDULE
24	10/15/12	PRELIMINARY SCHEDULE
25	10/15/12	PRELIMINARY SCHEDULE
26	10/15/12	PRELIMINARY SCHEDULE
27	10/15/12	PRELIMINARY SCHEDULE
28	10/15/12	PRELIMINARY SCHEDULE
29	10/15/12	PRELIMINARY SCHEDULE
30	10/15/12	PRELIMINARY SCHEDULE
31	10/15/12	PRELIMINARY SCHEDULE
32	10/15/12	PRELIMINARY SCHEDULE
33	10/15/12	PRELIMINARY SCHEDULE
34	10/15/12	PRELIMINARY SCHEDULE
35	10/15/12	PRELIMINARY SCHEDULE
36	10/15/12	PRELIMINARY SCHEDULE
37	10/15/12	PRELIMINARY SCHEDULE
38	10/15/12	PRELIMINARY SCHEDULE
39	10/15/12	PRELIMINARY SCHEDULE
40	10/15/12	PRELIMINARY SCHEDULE
41	10/15/12	PRELIMINARY SCHEDULE
42	10/15/12	PRELIMINARY SCHEDULE
43	10/15/12	PRELIMINARY SCHEDULE
44	10/15/12	PRELIMINARY SCHEDULE
45	10/15/12	PRELIMINARY SCHEDULE
46	10/15/12	PRELIMINARY SCHEDULE
47	10/15/12	PRELIMINARY SCHEDULE
48	10/15/12	PRELIMINARY SCHEDULE
49	10/15/12	PRELIMINARY SCHEDULE
50	10/15/12	PRELIMINARY SCHEDULE
51	10/15/12	PRELIMINARY SCHEDULE
52	10/15/12	PRELIMINARY SCHEDULE
53	10/15/12	PRELIMINARY SCHEDULE
54	10/15/12	PRELIMINARY SCHEDULE
55	10/15/12	PRELIMINARY SCHEDULE
56	10/15/12	PRELIMINARY SCHEDULE
57	10/15/12	PRELIMINARY SCHEDULE
58	10/15/12	PRELIMINARY SCHEDULE
59	10/15/12	PRELIMINARY SCHEDULE
60	10/15/12	PRELIMINARY SCHEDULE
61	10/15/12	PRELIMINARY SCHEDULE
62	10/15/12	PRELIMINARY SCHEDULE
63	10/15/12	PRELIMINARY SCHEDULE
64	10/15/12	PRELIMINARY SCHEDULE
65	10/15/12	PRELIMINARY SCHEDULE
66	10/15/12	PRELIMINARY SCHEDULE
67	10/15/12	PRELIMINARY SCHEDULE
68	10/15/12	PRELIMINARY SCHEDULE
69	10/15/12	PRELIMINARY SCHEDULE
70	10/15/12	PRELIMINARY SCHEDULE
71	10/15/12	PRELIMINARY SCHEDULE
72	10/15/12	PRELIMINARY SCHEDULE
73	10/15/12	PRELIMINARY SCHEDULE
74	10/15/12	PRELIMINARY SCHEDULE
75	10/15/12	PRELIMINARY SCHEDULE
76	10/15/12	PRELIMINARY SCHEDULE
77	10/15/12	PRELIMINARY SCHEDULE
78	10/15/12	PRELIMINARY SCHEDULE
79	10/15/12	PRELIMINARY SCHEDULE
80	10/15/12	PRELIMINARY SCHEDULE
81	10/15/12	PRELIMINARY SCHEDULE
82	10/15/12	PRELIMINARY SCHEDULE
83	10/15/12	PRELIMINARY SCHEDULE
84	10/15/12	PRELIMINARY SCHEDULE
85	10/15/12	PRELIMINARY SCHEDULE
86	10/15/12	PRELIMINARY SCHEDULE
87	10/15/12	PRELIMINARY SCHEDULE
88	10/15/12	PRELIMINARY SCHEDULE
89	10/15/12	PRELIMINARY SCHEDULE
90	10/15/12	PRELIMINARY SCHEDULE
91	10/15/12	PRELIMINARY SCHEDULE
92	10/15/12	PRELIMINARY SCHEDULE
93	10/15/12	PRELIMINARY SCHEDULE
94	10/15/12	PRELIMINARY SCHEDULE
95	10/15/12	PRELIMINARY SCHEDULE
96	10/15/12	PRELIMINARY SCHEDULE
97	10/15/12	PRELIMINARY SCHEDULE
98	10/15/12	PRELIMINARY SCHEDULE
99	10/15/12	PRELIMINARY SCHEDULE
100	10/15/12	PRELIMINARY SCHEDULE

CONTRACTOR COMMITMENTS

- The contractor commits to having a Designer complete at least biweekly inspections.
- The contractor commits to conducting inspections at least once every seven (7) days and within 24 hours after a precipitation event of 0.50-inches or more.
- The contractor commits to keeping copies of the construction site visit inspections and any modifications to the sediment and erosion control plans.
- The contractor commits to completing necessary maintenance activities on BMPs within seven (7) days of an inspection.
- The contractor commits to having one or more qualified technicians at the construction site at all times to be responsible for implementing, inspecting, and maintaining sediment and erosion control BMPs at all site areas requested or approved by the Designer.
- The contractor commits to installing additional sediment and erosion control BMPs within seven (7) days after being recommended by the Designer.
- If additional sediment and erosion control BMPs are recommended by the Designer, the contractor commits to completing all BMPs for the Designer regarding implementation of the additional BMPs.

1. NONE OF THESE CONTRACTOR COMMITMENTS FOR THIS PROJECT

DESIGNER SHALL HAVE REVIEWED AND APPROVED CONTRACTS AS HAS BEEN REQUIRED BY THE STATE OF FLORIDA AND SHALL BE RESPONSIBLE FOR THE DESIGNER'S OBLIGATIONS UNDER THE CONTRACT. THE DESIGNER SHALL BE RESPONSIBLE FOR THE DESIGNER'S OBLIGATIONS UNDER THE CONTRACT. THE DESIGNER SHALL BE RESPONSIBLE FOR THE DESIGNER'S OBLIGATIONS UNDER THE CONTRACT.

INDEX

- PRE- & DURING CONSTRUCTION SEDIMENT CONTROL PLAN
- AFTER CONSTRUCTION (A.K.A. EROSION CONTROL) PLAN
- TYPICAL DETAILS
- SPECIFICATIONS

U.S. APPROVED  
 DESIGN NUMBER

PROJECT NAME  
 SEDIMENT AND EROSION CONTROL PLAN  
 EXAMPLE TITLE PAGE



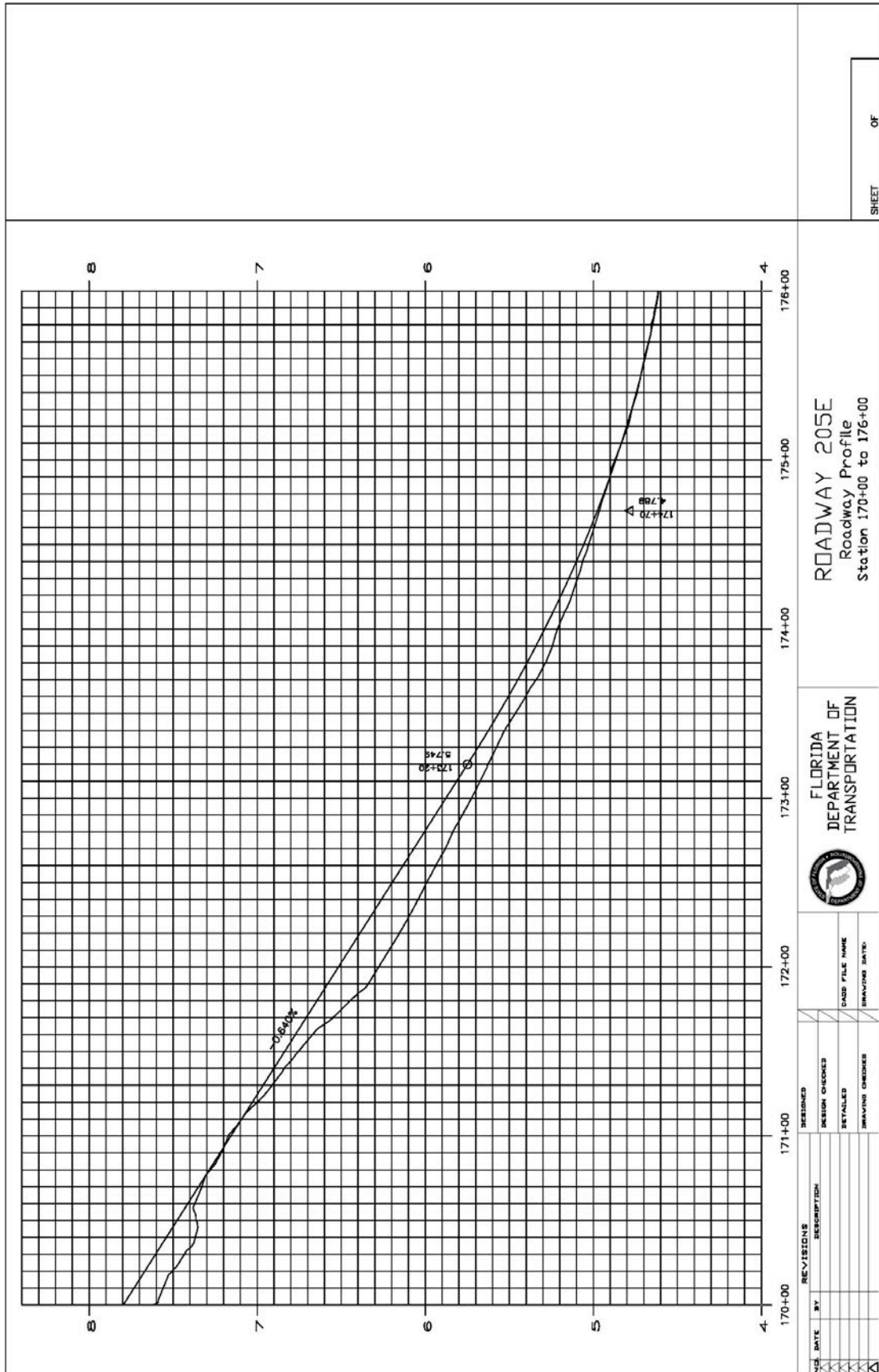

SHEET OF

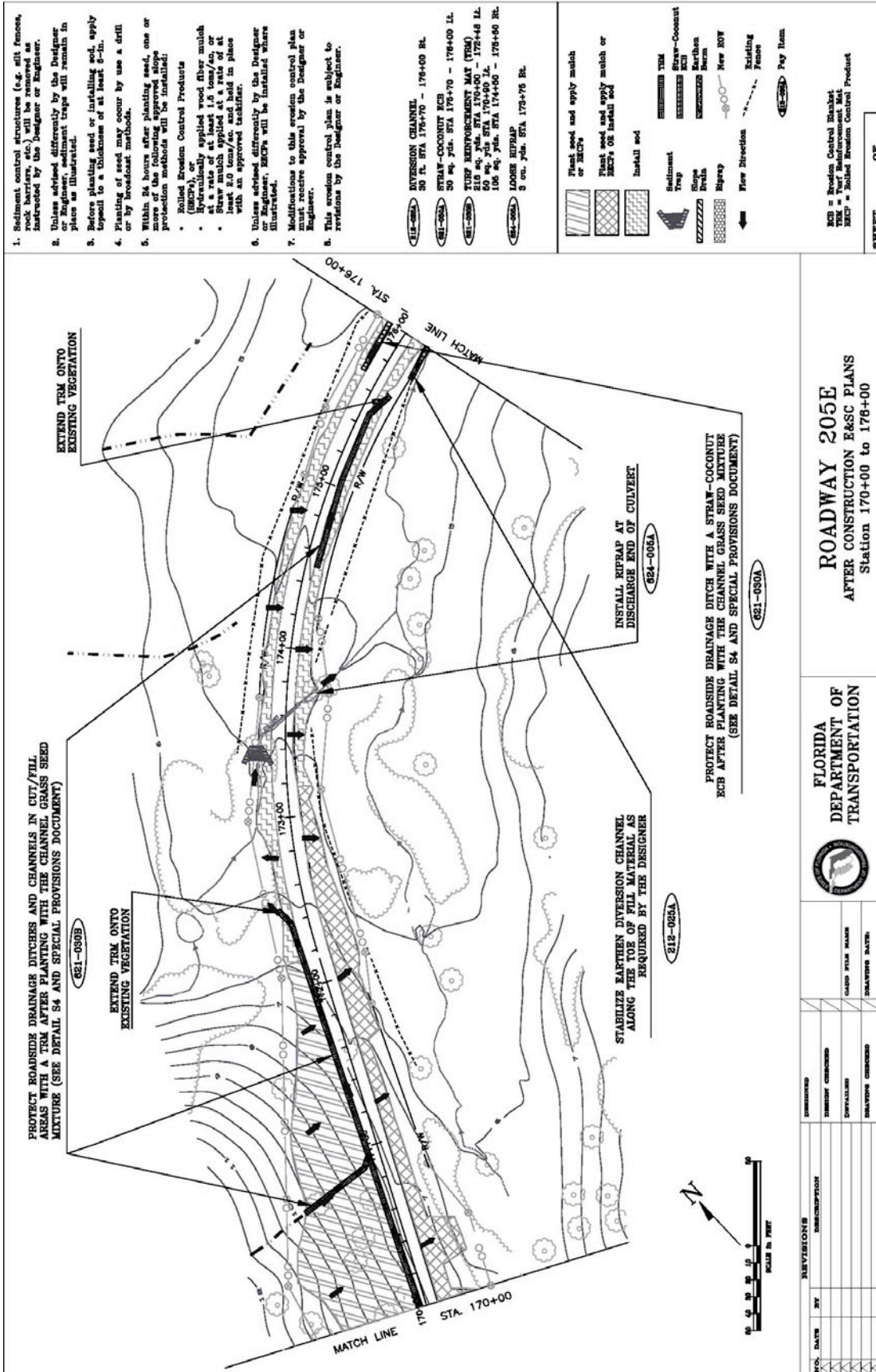

1. Sediment control structures (e.g. silt fences, rock barriers, etc.) will be removed as instructed by the Designer or Engineer.
  2. Unless advised differently by the Designer or Engineer, sediment traps will remain in place as illustrated.
  3. Before planting seed or installing sod, apply topsoil to a thickness of at least 6-in.
  4. Planting of seed may occur by use a drill or by broadcast methods.
  5. Within 24 hours after planting seed, one or more of the following approved slope protection methods will be installed:
    - Rolled Erosion Control Products (RECPs), or
    - Straw-Coconut ECB applied wood fiber mulch at a rate of at least 1.5 tons/ac, or
    - Earth blankets applied at a rate of at least 2.0 tons/ac. seed held in place with an approved tackifier.
  6. Unless advised differently by the Designer or Engineer, RECPs will be installed where illustrated.
  7. Modifications to this erosion control plan must receive approval by the Designer or Engineer.
  8. This erosion control plan is subject to variations by the Designer or Engineer.
- 612-005A** DIVERSION CHANNEL  
 30 ft. STA. 176+70 - 176+00 RL  
**611-005A** STRAW-COCONUT ECB  
 30 sq. yds. STA. 176+70 - 176+00 LL  
**611-005B** EROSION CONTROL MAT (ECM)  
 215 sq. yds. STA. 170+00 - 172+48 LL  
 60 sq. yds. STA. 170+00 LL - 172+48 LL  
 106 sq. yds. STA. 174+00 - 176+00 RL  
**611-005C** LOGS RIPRAP  
 3 sq. yds. STA. 176+76 RL
- Thick seed and apply mulch or RECPs  
 Plant seed and apply mulch or RECPs OR install sod  
 Install sod  
 Sediment Trap  
 Slope Brk  
 Riprap  
 Flow Direction  
 Existing Fence  
 Pay Item
- 611-005D** Straw-Coconut  
**611-005E** Earth Blanket  
**611-005F** New ROW  
**611-005G** Existing Fence  
**611-005H** Pay Item
- REB = Rolled Erosion Control Blanket  
 RECP = Rolled Erosion Control Product  
 RECM = Rolled Erosion Control Mat

**ROADWAY 205E**  
 AFTER CONSTRUCTION E&SC PLANS  
 Station 170+00 to 176+00

FLORIDA  
 DEPARTMENT OF  
 TRANSPORTATION



DESIGNED BY: \_\_\_\_\_  
 CHECKED BY: \_\_\_\_\_  
 DATE: \_\_\_\_\_

NO.	DATE	REVISIONS

NO.	DATE	BY	DESCRIPTION

NO.	DATE	BY	DESCRIPTION

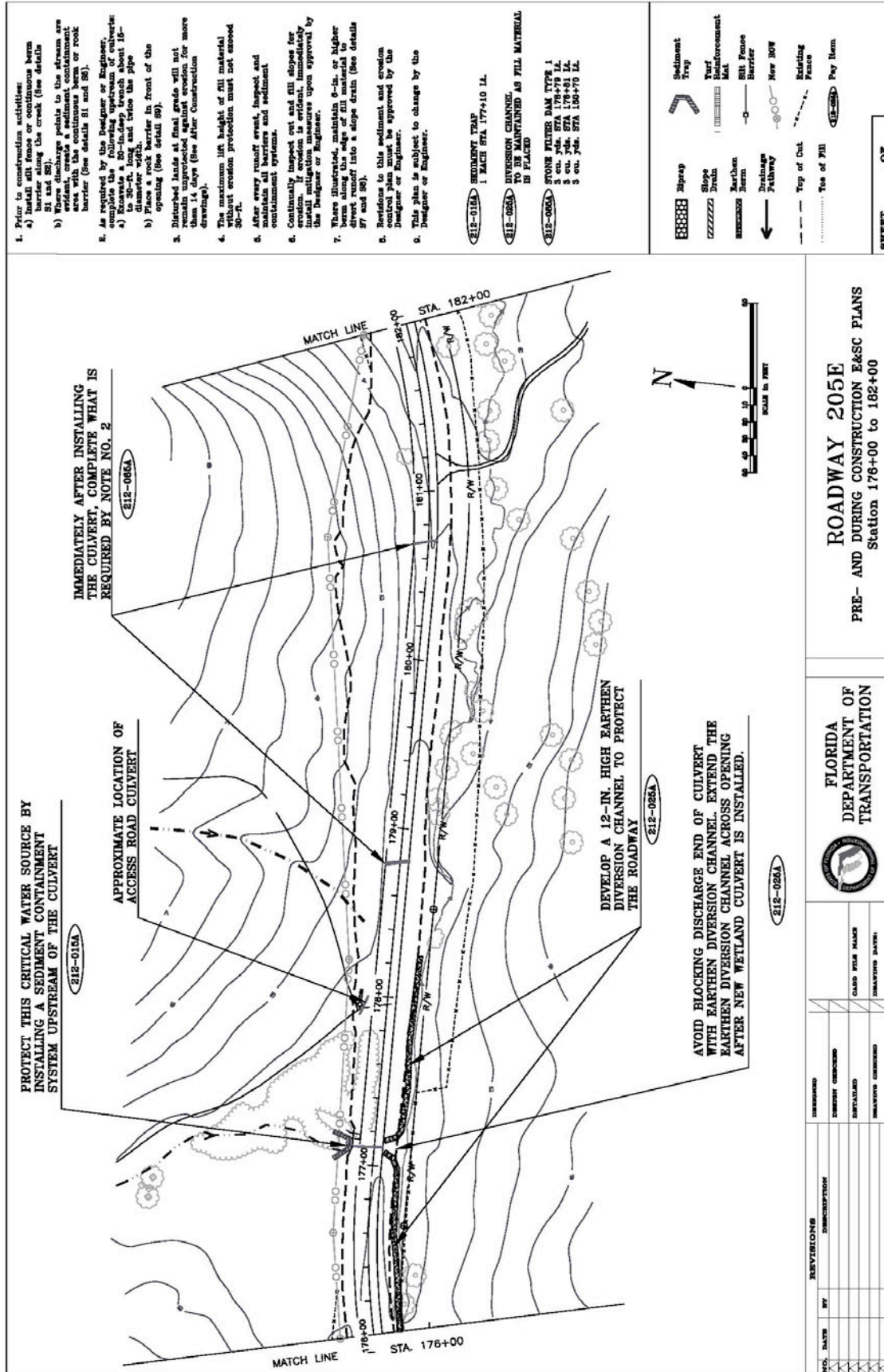

**ROADWAY 205E**  
 PRE- AND DURING CONSTRUCTION E&SC PLANS  
 Station 176+00 to 182+00

FLORIDA  
 DEPARTMENT OF  
 TRANSPORTATION

NO.	DATE	BY	REVISIONS	DESCRIPTION	DESIGNED	CHECKED	DATE	DESIGNED	CHECKED	DATE	DESIGNED	CHECKED	DATE

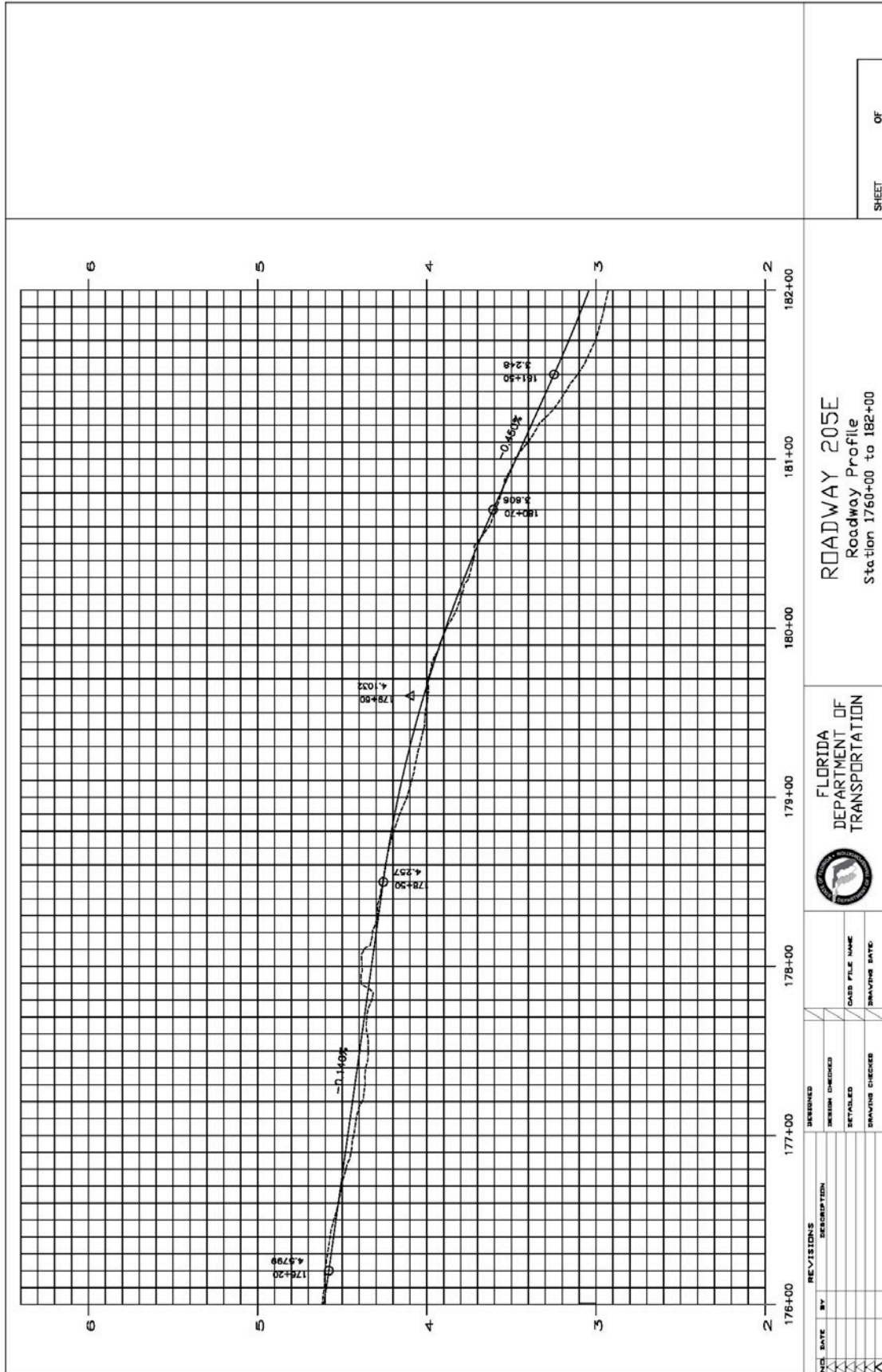







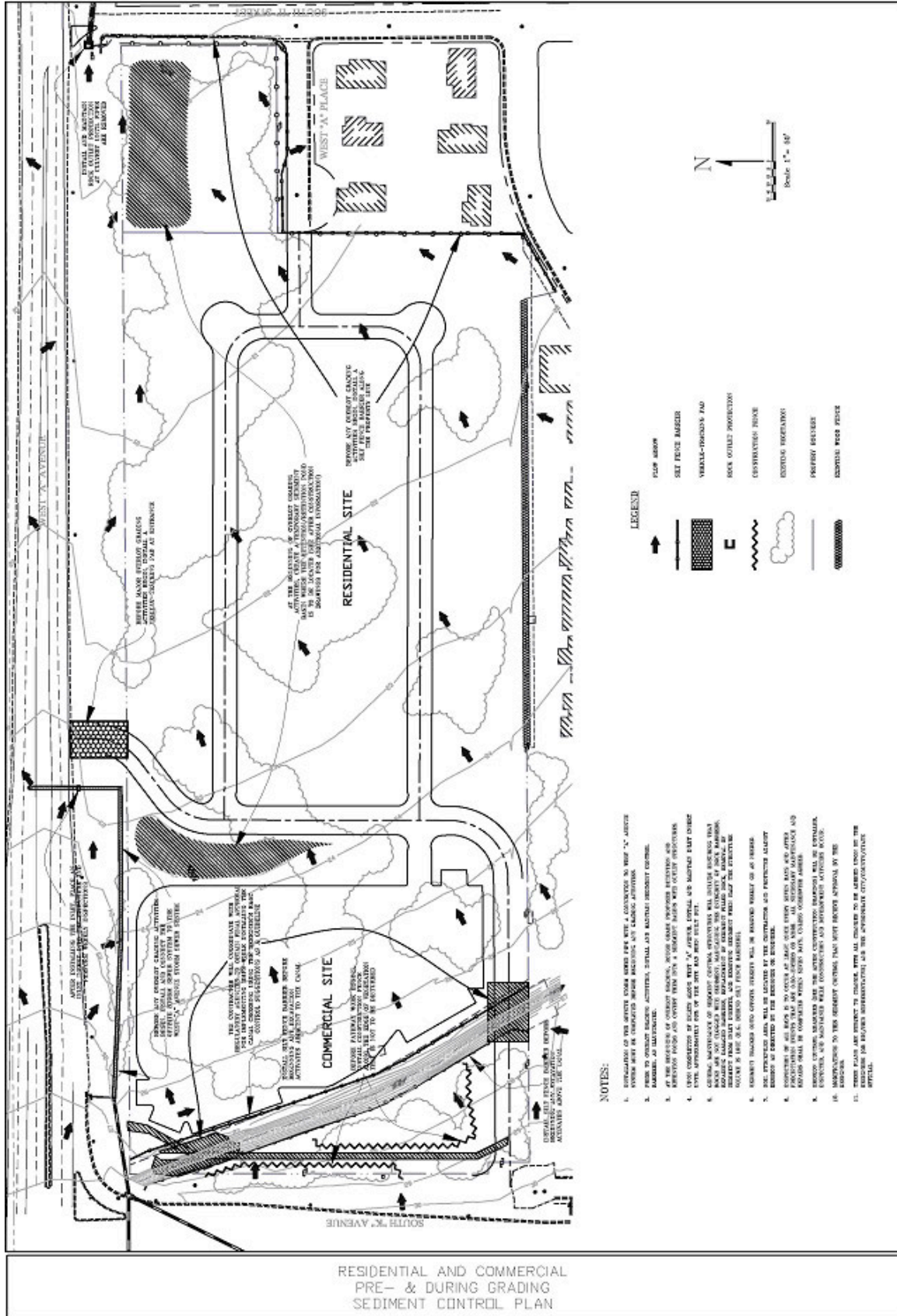



**SILT FENCE BARRIER INSTALLATION**

**TRENCHING METHOD**

REMOVE EXISTING CURB AND GUTTER MATERIAL TO A MINIMUM WIDTH OF 3'-0" TO 3'-6" (MINIMUM).  
 PLACE FABRIC MATERIAL WITH A 2'-0" TO 3'-0" OVERLAP TO THE EXISTING CURB AND GUTTER MATERIAL.  
 ATTACH FABRIC MATERIAL TO THE EXISTING CURB AND GUTTER MATERIAL WITH 2" GALVANIZED STEEL NAILS OR 1/2" DIA. STEEL NAILS SPACED AT 4'-0" TO 6'-0" (MAXIMUM).  
 COVER FABRIC MATERIAL WITH 18" TO 24" (MINIMUM) OF 1/2" TO 3/4" (MINIMUM) RADIUS OF CURB AND GUTTER MATERIAL.

**SLICING METHOD**

REMOVE EXISTING CURB AND GUTTER MATERIAL TO A MINIMUM WIDTH OF 3'-0" TO 3'-6" (MINIMUM).  
 PLACE FABRIC MATERIAL WITH A 2'-0" TO 3'-0" OVERLAP TO THE EXISTING CURB AND GUTTER MATERIAL.  
 ATTACH FABRIC MATERIAL TO THE EXISTING CURB AND GUTTER MATERIAL WITH 2" GALVANIZED STEEL NAILS OR 1/2" DIA. STEEL NAILS SPACED AT 4'-0" TO 6'-0" (MAXIMUM).  
 COVER FABRIC MATERIAL WITH 18" TO 24" (MINIMUM) OF 1/2" TO 3/4" (MINIMUM) RADIUS OF CURB AND GUTTER MATERIAL.

**SEDIMENT CONTAINMENT SYSTEM FAIRCLOTH® SURFACE SKIMMER**

INSTALL FAIRCLOTH® SURFACE SKIMMER TO REMOVE SEDIMENT FROM THE SURFACE OF THE CURB AND GUTTER. THE SKIMMER SHALL BE INSTALLED AT THE DOWN-SLOPE END OF THE CURB AND GUTTER. THE SKIMMER SHALL BE INSTALLED AT THE DOWN-SLOPE END OF THE CURB AND GUTTER. THE SKIMMER SHALL BE INSTALLED AT THE DOWN-SLOPE END OF THE CURB AND GUTTER.

**CURB AND GUTTER SEDIMENT CONTAINMENT SYSTEM**

PLACE TWO OR MORE SETS OF SAND BAGS IN A MANNER THAT RESULTS IN MAXIMUM SUPPORT. THE FLOW LINE BAG MUST BE LOWER THAN THE TOP OF THE CURB.

STREET GRADE (FT)	FLOOD SPACING (FT)
1.0	10
2.0	15
3.0	20
4.0	25
5.0	30

NOTE: FILL SAND BAGS ABOUT 2/3 FULL BEFORE PLACING IN THE GUTTER.

**ROCK BARRIER OUTLET STRUCTURE FOR CULVERTS**

INSTALL ROCK BARRIER OUTLET STRUCTURE TO PREVENT SOIL TRACKING FROM THE CULVERT TO THE ADJACENT ROADWAY. THE ROCK BARRIER SHALL BE INSTALLED AT THE DOWN-SLOPE END OF THE CULVERT. THE ROCK BARRIER SHALL BE INSTALLED AT THE DOWN-SLOPE END OF THE CULVERT. THE ROCK BARRIER SHALL BE INSTALLED AT THE DOWN-SLOPE END OF THE CULVERT.

**SOIL TRACKING PREVENTION DEVICE**

INSTALL SOIL TRACKING PREVENTION DEVICE TO PREVENT SOIL TRACKING FROM THE CULVERT TO THE ADJACENT ROADWAY. THE DEVICE SHALL BE INSTALLED AT THE DOWN-SLOPE END OF THE CULVERT. THE DEVICE SHALL BE INSTALLED AT THE DOWN-SLOPE END OF THE CULVERT. THE DEVICE SHALL BE INSTALLED AT THE DOWN-SLOPE END OF THE CULVERT.

RESIDENTIAL AND COMMERCIAL  
TYPICAL DETAILS PAGE 2

INSPECTION REQUIREMENTS FOR ALL INSTALLED BMPS

- AT LEAST ONCE EVERY 7 DAYS, INSPECT AND REPAIR ANY DAMAGE FOUND.
- REPAIR ANY DAMAGE FOUND.