



**DRAFT**

Manual of Uniform Minimum  
Standards for Design,  
Construction and Maintenance  
for Streets and Highways

*Commonly known as the*  
**Florida Greenbook**

---

FDOT Office of Design  
**Topic # 625-000-015**

Date of Publication  
**2023 Edition**

**Florida Greenbook**

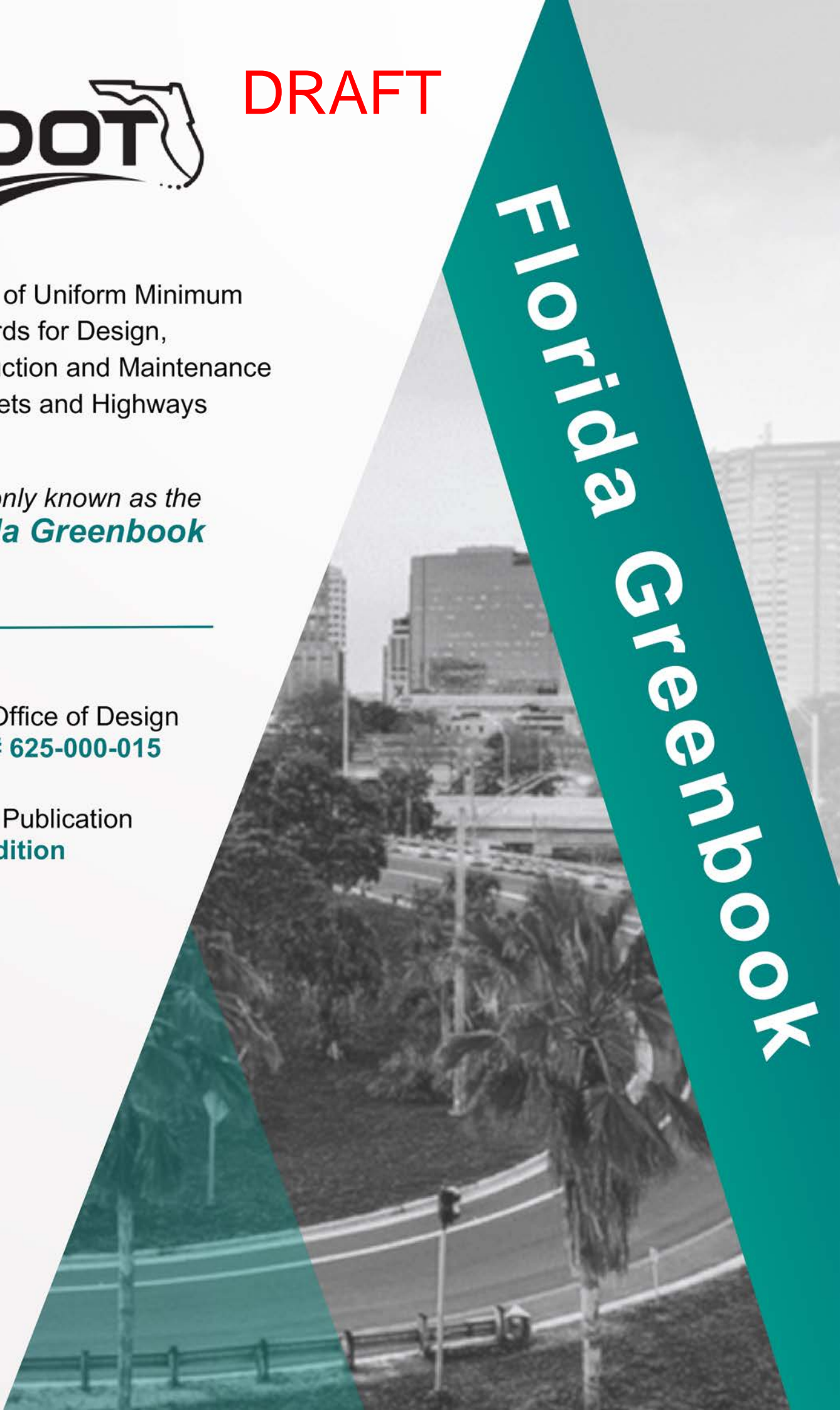

# DRAFT

Topic # 625-000-015  
Manual of Uniform Minimum Standards  
for Design, Construction and Maintenance  
for Streets and Highways

---

202318

## USER REGISTRATION

### ***Manual of Uniform Minimum Standards for Design, Construction and Maintenance for Streets and Highways***

(Commonly known as the ***Florida Greenbook***)

**202318** Edition

To: Florida Greenbook Users

The Florida Department of Transportation (FDOT) utilizes a contact database that enables ~~the Department~~ the FDOT to e-mail important information to registered users on topics selected by each user. The database allows a user to update their physical address, e-mail address, topics of interest, and any other information in their profile at any time.

All Florida Greenbook users must register their e-mail addresses in this contact database in order to receive updates, notices, design memos, or other important information concerning ~~the Department's~~ the FDOT's design manuals. Users must register at the following link:

<http://www.fdot.gov/designsupport/ContactDatabase.shtm>

New subscribers will need to create a new account. Once the information is registered, new subscribers will need to “Edit Interests.” The Florida Greenbook may be found under: Publications → Design → Roadway Design → Florida Greenbook”

# DRAFT

Topic # 625-000-015  
Manual of Uniform Minimum Standards  
for Design, Construction and Maintenance  
for Streets and Highways

---

202318

## TABLE OF CONTENTS

User Registration

Florida Greenbook Committee Members and Chapter Subcommittees

Purpose, ~~Policies~~ and ~~and~~ Objectives, and Definitions of Terms

Chapter 1	Planning <u>and Land Development</u>
Chapter 2	<del>Land Development</del> <u>Chapter Removed – See Chapter 1</u>
Chapter 3	Geometric Design
Chapter 4	Roadside Design
Chapter 5	Pavement Design and Construction
Chapter 6	Lighting
Chapter 7	Rail-Highway Crossings
Chapter 8	Pedestrian Facilities
Chapter 9	Bicycle Facilities
Chapter 10	Maintenance and Resurfacing
Chapter 11	Work Zone Safety <u>and Mobility</u>
Chapter 12	Construction
Chapter 13	Public Transit
Chapter 14	Design Exceptions and Variations
Chapter 15	Traffic Calming
Chapter 16	Residential Street Design
Chapter 17	Bridges and Other Structures
Chapter 18	Signing and Marking
Chapter 19	Traditional Neighborhood Development
Chapter 20	Drainage

# DRAFT

Topic # 625-000-015  
Manual of Uniform Minimum Standards  
for Design, Construction and Maintenance  
for Streets and Highways

---

2023~~18~~

**THIS PAGE INTENTIONALLY LEFT BLANK**

# DRAFT

## FLORIDA GREENBOOK COMMITTEE MEMBERS

202318

The Florida Greenbook Advisory Committee is composed of four professional engineers within each of the Department of Transportation's seven district boundaries as described in Section 336.045(2), Florida Statutes (F.S.).

### **Section 336.045, Florida Statutes. Uniform minimum standards for design, construction, and maintenance; advisory committees.**

(2) An advisory committee of professional engineers employed by any city or any county in each transportation district to aid in the development of such standards shall be appointed by the head of the department. Such committee shall be composed of: one member representing an urban center within each district; one member representing a rural area within each district; one member within each district who is a professional engineer and who is not employed by any governmental agency; and one member employed by the department for each district.

~~Contact information for the Florida Greenbook Advisory Committee members can be found on the Florida Greenbook web page:~~

~~<http://www.fdot.gov/roadway/FloridaGreenbook/FGB.shtm>~~

### **DEDICATION**

The 2023 Florida Greenbook is dedicated to Jeremy W. Fletcher (b.1970 – d.2022), who joined the Department in December 2006 in the Roadway Design Office (Tallahassee, Florida). His contributions and dedication to improve this vital document are recognized by the Department and the Florida Greenbook Advisory Committee.

The Florida Greenbook Advisory Committee Members at the time of publication are as follows:

### **DISTRICT 1**

Kevin Ingle, P.E.  
District Design Engineer  
FDOT - District 1

Shane Parker, P.E.  
Public Works Director  
Hendry County

# DRAFT

Topic # 625-000-015  
Manual of Uniform Minimum Standards  
for Design, Construction and Maintenance  
for Streets and Highways

---

202318

Ryan Bell, P.E., PTOE  
Director of Transportation  
Johnson Engineering, Inc.

Nikesh Patel, P.E.  
City Engineer  
City of Sarasota

## DISTRICT 2

Kathryn D. Thomas, P.E.  
District Design Engineer  
FDOT - District 2

Gene Howerton, P.E.  
Vice President  
Arcadis U.S., Inc.

Kenneth Dudley, P.E.  
County Engineer  
Taylor County

Ramon D. Gavarrete, P.E.  
County Engineer  
Alachua County

## DISTRICT 3

Adam Scurlock, P.E.  
District Design Engineer  
FDOT - District 3

Keith Bryant, P.E., P.T.O.E.  
Public Works Director  
Bay County

Rick Hall, P.E.  
Principal  
Hall Planning and Engineering, Inc.

[Chance Powell, P.E.](#)  
[Traffic Operations Engineer](#)  
[Walton County](#)

## DISTRICT 4

John Olson, P.E.  
District Design Engineer  
FDOT - District 4

Richard B. Szyrka, P.E.  
Director of Public Works  
Indian River County

Robert Behar, P.E.  
President  
R. J. Behar and Company, Inc.

Richard Tornese, P.E.  
County Engineer  
Broward County

## DISTRICT 5

Ed Kestory P.E.  
District Design Engineer  
FDOT - District 5

Gail Woods, P.E.  
Assistant Vice-President  
TranSystems

Ghulam Qadir, P.E.  
Chief Engineer  
Orange County Public Works

Deborah I. Snyder, P.E., P.T.O.E.  
Public Works Director  
Sumter County

# DRAFT

Topic # 625-000-015  
Manual of Uniform Minimum Standards  
for Design, Construction and Maintenance  
for Streets and Highways

---

202318

## DISTRICT 6

Karina Fuentes, P.E.  
District Design Engineer  
FDOT - District 6

Andres Garganta, P.E.  
Vice President  
WGI

Miguel Soria, P.E.  
Assistant Director, Highway Engineering  
Miami-Dade County

Juvenal Santana, P.E.  
Director  
City of Miami Public Works Department

## DISTRICT 7

Allan Urbonas, P.E.  
District Design Engineer  
FDOT - District 7

D. Todd Crosby, P.E.  
Assistant County Engineer  
Hernando County

Richard Diaz, Jr., P.E.  
President  
Diaz Pearson & Associates, Inc.

Calvin Hardie, P.E.  
Chief Design Engineer  
City of Tampa

## ASSOCIATE MEMBERS (Non-Voting)

Billy Hattaway, P.E.  
Transportation Department Director  
England-Thims & Miller, Inc

Charles Ramdatt, P.E., P.T.O.E., AICP  
Public Works Director  
City of Winter Park

Allen W. Schruppf, P.E.  
Senior Associate  
DRMP, Inc.

Kenneth J. Leeming, P.E.  
Highway Construction Manager  
Orange County Public Works

## FACERS LIAISON

Travis Terpstra, P.E. LEED GA  
Senior Project Manager  
Volusia County

## COMMITTEE STAFF

Derwood Sheppard, P.E.  
State Roadway Design Engineer  
FDOT - Central Office

Rhonda Taylor, P.E.  
Roadway Design Criteria Administrator  
FDOT - Central Office

# DRAFT

Topic # 625-000-015  
Manual of Uniform Minimum Standards  
for Design, Construction and Maintenance  
for Streets and Highways

---

202318

DeWayne Carver, CNUa  
Criteria Publications Manager  
FDOT – Central Office

Jacqui Morris, CPM, CNUa  
Criteria Publications Coordinator  
FDOT – Central Office

## CHAPTER TECHNICAL ADVISORS

Gabrielle (Gabe) Matthews  
Transit Planning Administrator  
FDOT – Central Office

David Cerlanek, P.E., P.T.O.E., CPM  
District Program Administration Engineer  
FDOT – District 2

Chris Wigglesworth  
Transit Planner  
FDOT – Central Office

Aurybell Rivero, Rivero, EI, MEVE  
Senior Transportation Planner  
Pasco County

Dana Knox  
Traffic Operations  
FDOT – Central Office

May Cheng, P.E.  
Traffic Signals/Street Lighting  
Palm Beach County Traffic Engineering  
Division

Richard Stepp, P.E.  
Standard Plans Engineer  
FDOT - Central Office

Alina Sardinias, MSCE  
Civil Engineer, Special Projects  
Palm Beach County Traffic Engineering  
Division

Benjamin J. Gerrell, P.E.  
Quality Assurance Engineer  
FDOT - Central Office

Jerald Marks  
Orange County Public Works

Andre Pavlov, P.E.  
Assistant State Structures Design  
Engineer  
FDOT – Central Office

Lauren Torres  
Project Manager, Traffic Engineering  
Orange County Public Works

Mary Jane Hayden, P.E.  
Roadway Quality Assurance Administrator  
FDOT - Central Office

Barry Westmark, P.E.  
Senior Engineer, Engineering Services  
Department,  
City of Largo

Rick Jenkins, P.E.  
State Standards Plans Engineer  
FDOT – Central Office

Rob Phelan, P.E.  
Lee County Department of Transportation

James Poole, P.E.  
District Drainage Design Engineer  
FDOT – District 4

William Corbett, P.E., P.T.O.E.  
City Traffic Engineer  
City of Cape Coral



# DRAFT

Topic # 625-000-015  
Manual of Uniform Minimum Standards  
for Design, Construction and Maintenance  
for Streets and Highways

---

202318

Alissa Torres, Ph.D., AICP, P.L.S.  
Chief Planner, Orange County  
Transportation Planning Division

Luis A. Alván, Esq., P.E.  
Senior Engineer  
Orange County Public Works

Frank C. Yokiell, AICP  
Orange County Public Works  
Engineering Division

Daryl Hildoer, P.E., ENV SP  
Stormwater Drainage Design Section  
Miami-Dade Department of Transportation  
and Public Works

Joanne Keller, P.E.  
Director of Land Development  
Engineering Department, Palm Beach  
County

Maria Molina, P.E.  
Chief, Right of Way Division  
Miami-Dade Department of Transportation  
and Public Works

Naomi Tillett, P.E.  
Engineer II, Public Works Department  
City of Lakeland

Liza Herrera, P.E., ENV SP  
Stormwater Drainage Design Section  
Miami-Dade Department of Transportation  
and Public Works

Juan Vasquez, P.E.  
Vice President  
R.J. Behar & Company

# DRAFT

Topic # 625-000-015  
Manual of Uniform Minimum Standards  
for Design, Construction and Maintenance  
for Streets and Highways

---

2023~~18~~

~~20196, 2020 and 202117~~

In addition to the members noted previously, the following served on the Florida Greenbook Committee or as Technical Advisors from 2019 through 2022~~in 2014 and 2015~~.

## DISTRICT 1

Alexandrea Davis-Shaw, P.E.  
City Engineer  
City of Sarasota  
Highlands County

Steven Neff, P.E.  
Public Works Director  
City of Cape Coral

Andy Tilton, P.E.  
Public Works Director  
Volusia County

## DISTRICT 2

John Veilleux, P.E.  
Supervising Engineer  
City of Gainesville

## DISTRICT 3

Thomas C. Phillips (Chris), P.E.  
County Engineer  
Santa Rosa County

Rodney Chamberlain, P.E.  
District Design Engineer  
FDOT - District 3

## DISTRICT 4

Steve Braun, P.E.  
District Design Engineer  
FDOT - District 4

## DISTRICT 5

Marrio Bizzio, P.E.  
District Design Engineer  
FDOT - District 5

Jeffrey Cicerello, P.E.  
District Design Engineer  
FDOT - District 5

# DRAFT

Topic # 625-000-015  
Manual of Uniform Minimum Standards  
for Design, Construction and Maintenance  
for Streets and Highways

---

202318

## DISTRICT 6

Daniel Iglesias, P.E.  
District Design Engineer  
FDOT - District 6

Gaspar Miranda, P.E.  
Assistant Director, Highway Engineering  
Public Works Department  
Miami-Dade County

## DISTRICT 7

Milton J. Martinez, P.E.  
Chief Transportation Engineer  
Transportation and Stormwater Services  
Department  
City of Tampa

[Margaret W. Smith, P.E.](#)  
[Engineering Services Director/  
County Engineer](#)  
[Pasco County](#)

## CENTRAL OFFICE

Catherine (Katey) Earp, P.E.  
Drainage Design Engineer  
FDOT - Central Office

[Gevin McDaniel, P.E., P.S.M.](#)  
[Roadway Design Criteria Administrator](#)  
[FDOT - Central Office](#)

[Mary Anne Koos, CPM](#)  
[Special Projects Coordinator](#)  
[FDOT – Central Office](#)

[Jeremy Fletcher, P.E., P.S.M.](#)  
[Roadway Quality Assurance Administrator](#)  
[FDOT – Central Office](#)

[Tim Lattner, P.E.](#)  
[Director, Office of Design](#)  
[FDOT - Central Office](#)

[Patrick Overton, P.E.](#)  
[State Utility Engineer](#)  
[FDOT - Central Office](#)

Michael Shepherd, P.E.  
Director, Office of Design  
FDOT - Central Office

## FACERS LIAISON

Benjamin Bartlett, P.E.  
Public Works Director  
Volusia County

# DRAFT

## CHAPTER SUBCOMMITTEES

The Chapter Chairs at the time of publication are as follows:

<u>Chapter</u>	<u>Chair</u>
1. Planning <u>and Land Development</u> .....	<del>Richard Tornese and</del> Rick Hall
2. Land Development .....	<del>Sunset Ricard Tornese</del>
3. Geometric Design .....	Andy Garganta
4. Roadside Design .....	Robert Behar
5. Pavement Design and Construction .....	<del>Margaret Smith</del> Kevin Ingle
6. Lighting .....	<del>Vacant</del> Keith Bryant Bernie Masing
7. Rail-Highway Crossings .....	<del>Karina Fuentes</del> Daniel Iglesias
8. Pedestrian Facilities .....	Ed Kestory <del>Mario Bizzio</del>
9. Bicycle Facilities .....	Ed Kestory <del>Mario Bizzio</del>
10. Maintenance and Resurfacing .....	Allan Urbonas
11. Work Zone Safety <u>and Mobility</u> .....	<del>Karina Fuentes</del> Daniel Iglesias
12. Construction .....	<del>Vacant</del> John Veilleux Richard Szpyrka
13. Public Transit .....	<del>Vacant</del> Juvenal Santana Milton Martinez
14. Design Exceptions and Variations .....	<del>Miguel Soria</del> Howard Webb
15. Traffic Calming .....	<del>Juvenal Santana</del> Billy Hattaway
16. Residential Street Design .....	<del>Margaret Smith</del> Richard Tornese
17. Bridges and Other Structures .....	Keith Bryant
18. Signing and Marking .....	Gail Woods
19. Traditional Neighborhood Development .....	<del>Rick Hall</del> Nikesh Patel
20. Drainage .....	Ryan Bell

# DRAFT

Topic # 625-000-015  
Manual of Uniform Minimum Standards  
for Design, Construction and Maintenance  
for Streets and Highways

---

20~~23~~<sup>18</sup>

**THIS PAGE INTENTIONALLY LEFT BLANK**

# DRAFT

## **PURPOSE, POLICIES AND OBJECTIVES, AND DEFINITIONS**

### **PURPOSE**

The purpose of this Manual is to provide uniform minimum standards and criteria for the design, construction, and maintenance of all transportation facilities off the State Highway System (SHS), roads, highways, bridges, sidewalks, curbs and curb ramps, crosswalks, bicycle facilities, underpasses, and overpasses used by the public for vehicular and pedestrian traffic as directed by **Sections 20.23(3)(a), 316.0745, 334.044(10)(a), and 336.045, F.S.**

The Florida Greenbook encourages context-based transportation planning and design. Context-based planning and design offers a diverse approach using existing tools in creative ways to improve the transportation system and meet the needs of users of all ages and abilities. This includes pedestrians, bicyclists, transit riders, motorists, and freight handlers. Planning and design of streets and highways must be based on the surrounding development patterns for existing and planned land development patterns. The approach also considers community needs, trade-offs between those needs, and alternatives to achieve multiple objectives. Context-based design principles help to promote safety, quality of life, and economic development.

In the following statutory excerpts, the term "Department" refers to the Florida Department of Transportation.

**Section 20.23, F.S. Department of Transportation.** There is created a Department of Transportation which shall be a decentralized agency.

**(3)(a)** The central office shall establish departmental policies, rules, procedures, and standards and shall monitor the implementation of such policies, rules, procedures, and standards in order to ensure uniform compliance and quality performance by the districts and central office units that implement transportation programs. Major transportation policy initiatives or revisions shall be submitted to the commission for review.

**Section 316.0745, F.S. Uniform signals and devices.**

**(1)** The Department of Transportation shall adopt a uniform system of traffic control devices for use on the streets and highways of the state. The uniform system shall, insofar as is practicable, conform to the system adopted by the American

Association of State Highway Transportation Officials and shall be revised from time to time to include changes necessary to conform to a uniform national system or to meet local and state needs. The Department of Transportation may call upon representatives of local authorities to assist in the preparation or revision of the uniform system of traffic control devices.

**Section 334.044, F.S. Department; powers and duties.** The department shall have the following general powers and duties:

**(10)(a)** To develop and adopt uniform minimum standards and criteria for the design, construction, maintenance, and operation of public roads pursuant to the provisions of **Section, 336.045, F.S.**

**Section 336.045, F.S. Uniform minimum standards for design, construction, and maintenance; advisory committees.**

**(1)** The department shall develop and adopt uniform minimum standards and criteria for the design, construction, and maintenance of all public streets, roads, highways, bridges, sidewalks, curbs and curb ramps, crosswalks, where feasible, bicycle ways, underpasses, and overpasses used by the public for vehicular and pedestrian traffic. In developing such standards and criteria, the department shall consider design approaches which provide for the compatibility of such facilities with the surrounding natural or manmade environment; the safety and security of public spaces; and the appropriate aesthetics based upon scale, color, architectural style, materials used to construct the facilities, and the landscape design and landscape materials around the facilities.

**(2)** An advisory committee of professional engineers employed by any city or any county in each transportation district to aid in the development of such standards shall be appointed by the head of the department. Such committee shall be composed of one member representing an urban center within each district; one member representing a rural area within each district; one member within each district who is a professional engineer and who is not employed by any governmental agency; and one member employed by the department for each district.

**(4)** All design and construction plans for projects that are to become part of the county road system and are required to conform with the design and construction standards established pursuant to subsection (1) must be certified to be in substantial conformance with the standards established pursuant to subsection (1) that are then in effect by a professional engineer who is registered in this state.

# DRAFT

Topic # 625-000-015  
Manual of Uniform Minimum Standards  
for Design, Construction and Maintenance  
for Streets and Highways

---

2023~~1~~2018

These standards are intended to provide basic guidance for developing and maintaining a highway system with reasonable operating characteristics and a minimum number of hazards.

Standards established by this Manual are intended for use on all transportation facilities off the State Highway System (SHS). Certain projects off the SHS but on the National Highway System (NHS) utilizing federal funds may be required to follow additional design criteria. Please see [Chapter 19](#) of the FDOT's [Local Agency Program Manual](#) for further information. Information on roadways included in the NHS is found at the FDOT's website: [National Highway System Maps](#).

Standards are provided for the design of new construction and reconstruction projects as well as maintenance and resurfacing projects. It is understood that existing streets and highways may not conform to all minimum standards applicable to the design of new and reconstruction projects. For existing roads not being replaced or reconstructed, it is intended the requirements provided in **Chapter 10 – Maintenance and Resurfacing** are applied. For all projects, there may be practical reasons a certain standard is not met. A process is provided in **Chapter 14 – Design Exceptions and Variations** to address those situations.

The Federal Highway Administration's [Manual on Uniform Traffic Control Devices, 2009 Edition \(MUTCD\)](#), has been adopted by [Rule 14 – 15.010, F.A.C.](#), and establishes a uniform system of traffic control devices. The [Manual on Uniform Traffic Control Devices \(2009 Edition with Revision Numbers 1 and 2, May 2012, MUTCD\)](#) includes additional requirements.

When this Manual refers to guidelines and design standards given by current American Association of State Highway and Transportation Officials (AASHTO) publications, these guidelines and standards shall generally be considered as minimum criteria. The FDOT may have standards and criteria that differ from the minimum presented in this Manual or by AASHTO for streets and highways under its jurisdiction. A county or municipality may substitute standards and criteria adopted by the FDOT for some or all portions of design, construction, and maintenance of their facilities. The ~~Department~~ [FDOT](#) standards, criteria, and manuals must be used when preparing projects on the state highway system or the national highway system.

Criteria and standards set forth in other manuals, which have been incorporated by reference, shall be considered as requirements within the authority of this Manual.



# DRAFT

Topic # 625-000-015  
Manual of Uniform Minimum Standards  
for Design, Construction and Maintenance  
for Streets and Highways

---

2023~~2018~~

This Manual is intended for use by qualified engineering practitioners for the communication of standards and criteria (including various numerical design values and use conditions). The design, construction, and maintenance references for the infrastructure features contained in this Manual recognize many variable and often complex process considerations. The engineering design process, and associated use of this Manual, incorporates aspects of engineering judgment, design principles, science, and recognized standards towards matters involving roadway infrastructure.

Users of this Manual are cautioned that the strict application of exact numerical values, conditions or use information taken from portions of the text may not be appropriate for all circumstances. Individual references to design values or concepts should not be used out of context or without supporting engineering judgment.

The contents of this Manual are reviewed annually by the Florida "Greenbook" Advisory Committee. Membership of this committee is established by the above referenced **Section 336.045(2), F.S.** Comments, suggestions, or questions may be directed to any committee member.

## POLICIES AND OBJECTIVES

Specific policies governing the activities of planning, design, construction, reconstruction, maintenance, or operation of streets and highways are listed throughout this Manual. This manual uses a context-based design approach that considers the mobility, convenience, accessibility, and safety of all road users; and places an emphasis on the most vulnerable users of a given transportation facility. Decisions ~~shall~~~~should~~ be predicated upon meeting the following objectives:

- A. Specifies all users - Provide streets and highways with operating characteristics that support users of all ages and abilities.
  - ✓ Incorporate appropriate context based design elements when planning and designing the transportation network.
  - ✓ Draw on all sources of transportation funding to implement context based design.
  - ✓ Seek input from a variety of local stakeholders when designing or revising transportation projects to promote equity and meet the diverse needs of system users.
- B. Applies to all projects - Each transportation agency should establish and maintain a program to promote context based design in all activities on streets and highways under its jurisdiction.
  - ✓ Planning, design, construction, and maintenance activities are all essential activities for implementing context-based design.
- C. Procedure for exceptions and variations – When proposed design elements do not meet the criteria contained in this Manual, sufficient detail and justification of such deviations must be documented.
  - ✓ Sufficient detail and explanation must be given to justify approval to those reviewing the request.
  - ✓ Consider potential mitigation strategies that may reduce the adverse impacts to highway safety and traffic operations.

# DRAFT

- D. Creates a network - Design, operate, and maintain a transportation system that provides a highly connected and diverse network of streets that accommodate all intended modes of travel.
- ✓ Place a priority on connecting communities with economic and employment centers and visitor destinations.
  - ✓ Prioritize non-motorized connectivity improvements to services, schools, parks, civic uses, regional connections, and commercial uses.
  - ✓ Identify routes for freight traffic that provide access to industrial centers, warehouses, distribution centers (rail, freight, intermodal), and ports (airports, seaports, and space ports).
  - ✓ Consider the “last mile” needs of freight handlers and transit riders.
  - ✓ Seek opportunities to repurpose or add new rights of way to enhance connectivity for pedestrians, bicyclists, and transit or shift freight traffic to more appropriate corridors.
- E. Adoptable by all agencies - A well-connected, diverse transportation system supports Florida’s existing and future economic development.
- ✓ Increase productivity by improving the accessibility of people and businesses to reach jobs, services, goods, and activities.
  - ✓ Increase level of accountability for metropolitan, regional, and local agencies to demonstrate the need, economic impact, and return of transportation investments.
  - ✓ Strengthen local policies, ordinances requiring new development or redevelopment to provide interconnected street networks with small blocks that connect with existing or planned streets on the perimeter.
  - ✓ Support regional land use, economic development goals, and regional vision.
- F. Latest and best design criteria - Provide uniformity and consistency in the design and operation of streets and highways.
- ✓ Strive to design and maintain facilities that are consistent with the local context, through single projects or incremental improvements over time.

# DRAFT

- ✓ Document conditions that may preclude achieving full multi-modal design, such as environmental, historical or cultural constraints, limited right of way, or disproportionate cost.
  - ✓ Anticipate needs of connected and autonomous vehicles and other emerging technologies.
- G. Context-sensitive - Transportation investments should align with land use, and support a community's quality of life. A context-based approach helps communities and regions make sound decisions which support their long-term vision.
- ✓ Harmonize the transportation system with adjacent existing or proposed context such as neighborhoods, business districts, commercial areas, and public services (schools, parks, health, and entertainment centers).
  - ✓ Design streets with a strong sense of place; use architecture, landscaping, streetscaping, public art, and signage to reflect the community, neighborhood, history, and natural setting.
  - ✓ Highlight natural features such as waterways, trees, scenic views, slopes, and preserved lands and minimize impacts.
- H. Establishes performance measures - Develop and maintain a transportation system that provides a safe environment.
- ✓ Understand that children, elderly adults, and persons with disabilities may require appropriate accommodations.
  - ✓ Establish and maintain procedures for construction, maintenance, utility, and emergency operations that provide for safe operating conditions during these activities.
  - ✓ Use existing street pavement widths as efficiently as possible to accommodate all modes of transportation, recognizing that allocating designated space by mode is preferred, but shared facilities may be the most practical solution in some cases.
- I. Includes specific next steps for implementation.
- ✓ Understand the priorities and concerns by reaching out to stakeholders, collect data, synthesize issues and opportunities, and define context classifications.

# DRAFT

Topic # 625-000-015  
Manual of Uniform Minimum Standards  
for Design, Construction and Maintenance  
for Streets and Highways

---

~~2023~~2018

- ✓ Define the project's purpose, needs and evaluation measures (i.e., person throughput, network completeness, street connectivity, access to jobs, housing, retail, public facilities).
- ✓ Define and evaluate alternatives.

Additional general and specific objectives related to various topics and activities are listed throughout this Manual. Where specific standards or recommendations are not available or applicable, the related objectives shall be utilized as general guidelines.

# DRAFT

## DEFINITIONS OF TERMS

The following terms shall, for the purpose of this Manual, have the meanings respectively ascribed to them, except instances where the context clearly indicates a different meaning. The [Manual on Uniform Traffic Control Devices \(2009 Edition with Revision Numbers 1 and 2, May 2012, MUTCD\)](#) includes additional information on terms used in conjunction with the application of the **MUTCD**.

<b>Alley</b>	A narrow right of way to provide access to the side or rear of individual land parcels.
<b>Annual Average Daily Traffic (AADT)</b>	The total volume of traffic on a highway segment for one year, divided by the number of days in the year. This volume is usually estimated by adjusting a short-term traffic count with weekly and monthly factors.
<b>Average Daily Traffic (ADT)</b>	The total traffic volume during a given time period (more than a day, less than a year) divided by the number of days in that time period.
<b>Auxiliary Lane</b>	A designated width of roadway pavement marked to separate speed change, turning, passing, and climbing maneuvers from through traffic.
<b>Average Running Speed</b>	For all traffic, or component thereof, the summation of distances divided by the summation of running times.
<b>Bicycle Lane (Bike Lane)</b>	A portion of a roadway that has been designated for preferential use by bicyclists by pavement markings, and if used, signs. They are one-way facilities that typically carry traffic in the same direction as adjacent motor vehicle traffic.

# DRAFT

**Boarding And Alighting (B&A) Area**

A firm, stable, slip resistant surface that accommodates passenger movement on or off a transit vehicle.

**Border Area**

The border area provides space for roadside design components (e.g., signing, drainage features, sidewalks, and traffic control devices), a buffer between vehicles and pedestrians, and permitted public utilities. It also provides space for construction and maintenance of the facility.

**Bridge**

A structure, including supports, erected over a depression or an obstruction, such as water, a highway, or a railway, having a track or passageway for carrying traffic or other moving loads, and having a total span of more than 20 feet between undercopings of abutments.

**Clear Zone**

The unobstructed, traversable area beyond the edge of the traveled way for the recovery of errant vehicles. The clear zone includes shoulders and bicycle lanes.

**Context Classification System**

Broadly identifies the built environments in Florida, based upon existing and future land use characteristics, development patterns, network scale, and roadway connectivity of an area.

**Corridor**

A strip of land between two termini within which traffic, topography, environment, population, access management, and other characteristics are evaluated for transportation purposes.

**Cross Slope**

The transverse slope and/or superelevation described by the roadway section geometry.

# DRAFT

## **Crosswalk**

Portion of the roadway at an intersection included within the connections of lateral lines of the sidewalks on opposite sides of the highway, measured from the curbs or in the absence of curbs from the traversable roadway. Crosswalks may also occur at an intersection or elsewhere distinctly indicated for pedestrian crossing.

## **Design Hour Volume (DHV)**

Traffic volume expected to use a highway segment during the design hour of the design year. The DHV is related to the AADT by the “K” factor. It includes total traffic in both directions of travel.

## **Design Year**

Both current and future traffic volumes are considered in design. Future traffic volumes expected to use a particular facility are projected for the design year, which is usually 10 to 20 years in the future.

## **Directional Design Hour Volume (DDHV)**

Traffic volume expected to use a highway segment during the design hour of the design year in the peak direction.

## **Design Speed**

A selected speed used to determine the various geometric design features of the roadway. The selected design speed should be a logical one with respect to the topography, anticipated operating speed, adjacent land use, and functional classification of the highway.

## **Design User**

Anticipated users of a roadway (including pedestrians, bicyclists, transit riders, motorists, and freight handlers) that form the basis for each roadway’s design.



# DRAFT

<b>Design Vehicle</b>	A vehicle, with representative weight, dimensions, and operating characteristics, used to establish highway design controls for accommodating vehicles of designated classes.
<b>Driveway</b>	An access from a public way to adjacent property.
<b>Expressway</b>	A divided arterial highway for through traffic with full or partial control of access and generally with grade separations at major intersections.
<b>Federal Aid Highway</b>	A highway eligible for assistance under the United States Code Title 23 other than a highway classified as a local road or rural minor collector.
<b>Freeway or Limited Access Highway</b>	<u>A controlled access, divided arterial highway with grade separation at intersections.</u> <del>An expressway with full control of access.</del>
<b>Frontage Road or Street</b>	A street or highway constructed adjacent to a higher classification street or other roadway network serving adjacent property or control access.
<b>Grade Separation</b>	A crossing of two roadways or a roadway and a railroad or pedestrian pathway at different levels.
<b>High Speed</b>	Speeds of 50 mph or greater.
<b>High-Speed Rail</b>	Intercity passenger rail service that is reasonably expected to reach speeds of at least 110 miles per hour.
<b>Highway</b>	<u>A high-speed roadway (divided or undivided) intended for travel between destinations like cities and towns.</u>

# DRAFT

## **Highway, Street, or Road**

General terms, denoting a public way for purposes of traffic, both vehicular and pedestrian, including the entire area within the right of way. The term street is generally used for urban or suburban areas.

## **Intersection**

The general area where two or more streets or highways join or cross.

## **Lateral Offset**

The lateral distance from the edge of the traveled way or when applicable, face of curb, to a roadside object or feature.

## **Low Speed**

Speeds less than or equal to 45 mph.

## **May**

A permissive condition. Where "may" is used, it is considered to denote permissive usage.

## **Maintenance**

A strategy of treatments to an existing roadway system that preserves it, retards future deterioration, and maintains or improves the functional condition.

## **New Construction**

The construction of any public way (paved or unpaved) where none previously existed, or the act of paving any previously unpaved road, except as provided in Chapter 3, Section A of these standards.

## **Operating Speed**

The rate of travel at which vehicles are observed traveling during free-flow conditions.

## **Paratransit**

Comparable transportation service required by the ADA for individuals with disabilities who are unable to use fixed route transportation systems.

# DRAFT

## **Pedestrian Access Route**

A continuous and unobstructed path of travel provided for pedestrians with disabilities within or coinciding with a pedestrian circulation path.

## **Pedestrian Circulation Path**

A prepared exterior or interior surface provided for pedestrian travel in the public right of way.

## **Preferential Lane**

A street or highway lane reserved for the exclusive use of one or more specific types of vehicles or vehicles with at least a specific number of occupants.

## **Public Way**

All public streets, roads, highways, bridges, sidewalks, curbs and curb ramps, crosswalks (where feasible), bicycle facilities, underpasses, and overpasses used by the public for vehicular and pedestrian traffic.

## **Ramp**

1) Includes all types, arrangements, and sizes of turning roadways that connect two or more legs at an interchange. 2) A combined ramp and landing to accomplish a change in level at a curb (curb ramp).

## **Reconstruction**

Streets and highways that are rebuilt primarily along existing alignment. Reconstruction normally involves full-depth pavement replacement. Other work that would fall into the category of reconstruction would be adding lanes adjacent to an existing alignment, changing the fundamental character of the roadway (e.g., converting a two-lane highway to a multi-lane divided arterial) or reconfiguring intersections and interchanges.

## **Recovery Area**

A clear zone that includes the total roadside border area, starting at the edge of the traveled way, available for safe use by errant vehicles.

# DRAFT

## Residential Streets

Streets primarily serving residential access to the commercial, social, and recreational needs of the community. These are generally lower volume and lower speed facilities than the primary arterial and collector routes of the local system "or as adopted by local government ordinance".

## Resurfacing

Work to place additional layers of surfacing on highway pavement, shoulders, bridge decks and necessary incidental work to extend the structural integrity of these features for a substantial time period.

## Right of Way

A general term denoting land, property or interest therein, usually in a strip, acquired or donated for transportation purposes. More specifically, land in which the State, the FDOT, a county, a transit authority, municipality, or special district owns the fee or has an easement devoted to or required for use as a public road.

## Roadway

A prepared surface (asphalt, concrete, brick, or other materials) for use primarily by vehicles, including shoulders and adjacent bicycle lanes. A divided roadway provides a separation between opposing traffic lanes.~~The portion of a street or highway, including shoulders, for vehicular use. A divided highway has two or more roadways~~

## Rural Areas

Those areas outside of urban boundaries. Urban area boundary maps based upon the 2010 Census are located on the ~~the~~ [FDOT's Urban Area 1-Mile Buffer Maps.](#)

# DRAFT

## Shall or Must

A mandatory condition. (When certain requirements are described with the "shall" or "must" stipulation, it is mandatory these requirements be met.)

## Shared Lane

Roadways where no bicycle lanes or adjacent shoulders usable by bicyclists are present and where travel lanes are too narrow for bicyclists and motor vehicles to operate side by side.

## Shared Roadway

A roadway that is open to pedestrian, bicycle, motor vehicle, street cars, and rail travel. This may be an existing roadway, street with wide curb lanes, or road with paved shoulders.

## Shared Street

Street that includes a shared zone where pedestrians, bicyclists, and motor vehicles mix in the same space. The design supports slower vehicle speeds and lower motor vehicle volumes. It lacks design elements that suggest motor vehicle priority or segregate modes; and includes elements that suggest a pedestrian priority (e.g., gathering areas, seating, lighting, art, special plantings).

## Shared Use Path or Multi - Use Trail

A facility with a firm, stable, slip-resistant surface physically separated from motorized vehicular traffic by an open space or barrier with minimal cross flow by motor vehicles. Users may include pedestrians, bicyclists, skaters, and others. Special design and approval is needed when travelers use vehicles such as golf carts or other motorized devices.

## Should

An advisory condition. Where the word "should" is used, it is considered to denote advisable usage, recommended but not mandatory.

# DRAFT

<b>Slope</b>	The relative steepness of the terrain, expressed as a ratio or percentage. Slopes may be categorized as positive (backslopes) or negative (foreslopes) and as parallel or cross slopes in relation to the direction of traffic. In this manual slope is expressed as a ratio of vertical to horizontal (V:H).
<b>Surface Transportation System</b>	Network of highways, streets, and/or roads. Term can be applied to local system or expanded to desired limits of influence.
<b>Traditional Neighborhood Development (TND)</b>	TND refers to the development or redevelopment of a neighborhood or town using traditional town planning principles. Projects should include a range of housing types and commercial establishments, a network of well-connected streets and blocks, civic buildings and public spaces, and include other uses such as stores, schools, and places of worship within walking distances of residences.
<b>Traffic</b>	Pedestrians, bicyclists, motor vehicles, streetcars and other conveyances either singularly or together while using for purposes of travel any highway or private road open to public travel.
<b>Traffic Lane</b>	Includes travel lanes, auxiliary lanes, turn lanes, weaving, passing, and climbing lanes.
<b>Travel Lane</b>	A designated width of roadway pavement marked to carry through traffic and to separate it from opposing traffic or traffic occupying other traffic lanes. Generally, travel lanes equate to the basic number of lanes for a facility.
<b>Traveled Way</b>	The portion of the roadway for the movement of vehicles, exclusive of shoulders and bicycle lanes.

# DRAFT

## Turning Roadway

A connecting roadway for traffic turning between two intersection legs.

## Urban Area

A geographic region comprising, as a minimum, the area inside the United States Bureau of the Census boundary of an urban place with a population of 5,000 or more persons, expanded to include adjacent developed areas as provided for by Federal Highway Administration (FHWA) regulations. Urban area boundary maps based upon the 2010 Census are located on the [the FDOT's Urban Area 1-Mile Buffer Maps](#).

## Urbanized Area

A geographic region comprising, as a minimum, the area inside an urban place of 50,000 or more persons, as designated by the United States Bureau of the Census, expanded to include adjacent developed areas as provided for by Federal Highway Administration (FHWA) regulations. Urban areas with a population of fewer than 50,000 persons which are located within the expanded boundary of an urbanized area are not separately recognized.

## Vehicle

Every device upon, or by which any person or property is or may be transported or drawn upon a traveled way, excepting devices used exclusively upon stationary rails or tracks. Bicycles are defined as vehicles per Section 316.003, [Florida Statutes F.S.](#)

## Vertical Clearance

Minimum unobstructed vertical passage space.

## Very Low-Volume Road

A road that is functionally classified as a local road and has a design average daily traffic volume of 400 vehicles per day or less.

# DRAFT

Topic # 625-000-015  
Manual of Uniform Minimum Standards  
for Design, Construction and Maintenance  
for Streets and Highways

---

~~2018~~2023

## **Wide Outside Lane**

Through lanes that provide a minimum of 14 feet in width. This lane should always be the through lane closest to the curb or shoulder of the road when a curb is not provided.



# DRAFT

## CHAPTER 1

### PLANNING AND LAND DEVELOPMENT

A	CONTEXT-BASED PLANNING AND DESIGN .....	1-1
B	CLASSIFICATION .....	1-2
	B.1 Functional Classification .....	1-2
	B.2 Context Classification .....	1-4
	B.3 Design Speed .....	1-7
C	CONSIDERATIONS FOR DESIGN .....	1-7
	C.1 Safety .....	1-7
	C.2 Economic Constraints .....	1-7
	C.3 Access Requirements .....	1-8
	C.4 Measures of Level of Service .....	1-8
	C.5 Maintenance Capabilities .....	1-8
	C.6 Utility and Transit Operations .....	1-8
	C.7 Emergency Response .....	1-9
	C.8 Environmental Impact .....	1-9
	C.9 Community and Social Impact .....	1-9
D	LANE REPURPOSING .....	1-10
E	LAND DEVELOPMENT .....	1-11
	E.1 Development Types and Guidelines .....	1-11
	E.1.a Conventional Suburban Design .....	1-12
	E.1.b Traditional Neighborhood Design (TND) .....	1-12
	E.1.c Transit-Oriented Design (TOD) .....	1-12
	E.2 Space Allocation .....	1-13
	E.3 Access Control .....	1-13
	E.4 Control Techniques .....	1-14
	E.4.a Right of Way Acquisition .....	1-14
	E.4.b Regulatory Authority .....	1-14
	E.4.b.1 General Regulatory Requirements .....	1-14
	E.4.b.2 Specific Control .....	1-15

# DRAFT

E.5	Contracts and Agreements .....	1-15
E.6	Education.....	1-16
F	OPERATION .....	1-17
F.1	Policy .....	1-17
F.2	Objectives.....	1-17
F.3	Activities.....	1-17
F.3.a	Maintenance and Reconstruction .....	1-18
F.3.b	Work Zone Safety.....	1-18
F.3.c	Traffic Control .....	1-18
F.3.d	Emergency Response.....	1-19
F.3.e	Coordination and Supervision.....	1-19
F.3.f	Inspection and Evaluation.....	1-19
G	REFERENCES FOR INFORMATIONAL PURPOSES .....	1-20

## TABLES

Table 1 – 1	Functional Classification Types .....	1-3
-------------	---------------------------------------	-----

## FIGURES

Figure 1 – 1	Context Classifications.....	1-5
--------------	------------------------------	-----

## CHAPTER 1

### PLANNING AND LAND DEVELOPMENT

#### A CONTEXT-BASED PLANNING AND DESIGN

In 1996, the Federal Highway Administration (FHWA) released guidance encouraging context-based transportation planning and design. Since then, many regional and local transportation agencies in Florida and throughout the U.S. have adopted context-based planning and design policies and practices. Context-based planning and design offers a flexible approach using existing tools in creative ways to address multimodal needs in different contexts. The approach also considers community needs, trade-offs between those needs, and alternatives to achieve multiple objectives.

The Florida Greenbook's Context-Based Design policy captures three core concepts:

- Serve the needs of transportation system users of all ages and abilities, including pedestrians, bicyclists, transit riders, motorists, and freight handlers.
- Design streets and highways based on local and regional land development patterns that reflect existing and future context.
- Promote safety, quality of life, and economic development.

This Context-Based approach builds on flexibility and innovation to ensure that all streets and highways are developed based on their context classification, as determined by the local jurisdiction to the maximum extent feasible. With a Context-Based approach, every non-limited access transportation project, including those on the Strategic Intermodal System (SIS) or part of a residential, commercial, industrial development is uniquely planned and designed to serve the context of that roadway and the safety, comfort, and mobility of all users.

In a high-speed rural context, where higher truck traffic is anticipated, and walking and bicycling are infrequent, wider travel lanes with paved shoulders are appropriate. Shared use paths as part of a regional trail system or for access to schools or parks may also be needed. In urban contexts, where high volumes of pedestrians, bicyclists, and transit users are expected or desired, a roadway should include features such as wide sidewalks, bicycle facilities, transit stops, and frequent, pedestrian crossing opportunities.

Limited-access highways may incorporate elements of context-based design where they connect to the non-limited-access system.

Planning for communities occurs at several levels, including the region, city/town, community, block, and, finally, street and building. Planning should be holistic, looking carefully at the relationship between land use, buildings, and transportation in an integrated fashion. This approach, and the use of form-based codes, can create development patterns and transportation networks that balance walking, bicycling, and transit with motor vehicle transportation.

## B CLASSIFICATION

Designs for transportation projects are based on established design controls for the various elements of the project such as width, side slopes, horizontal and vertical alignment, drainage, accessibility, and intersection considerations.

The design criteria presented in this manual are based on:

- Functional Classification
- Context Classification
- Design Speed

A determination of the functional and context-based design and operational requirements, and a clear definition of the classification of each new facility isare determined by the local government with jurisdiction over the street or highway. There should be consultation among local governments in determining the classification. The determination is required prior to the actual design.

### B.1 Functional Classification

Functional classification is the grouping of highways by the character of service and connectivity they provide in relation to the total road network. Table 1 – 1 Functional Classification Types summarizes the primary characteristics of each functional classification.

Functional road classifications for Florida are defined in [Section 334.03 F.S.](#) The **AASHTO** publication ***A Policy on Geometric Design of Highways and Streets (2011)*** presents an excellent discussion on highway functional classifications.

e.1

**Table 1 – 1 Functional Classification Types**

<b>Functional Classification</b>	<b>Primary Characteristics</b>
<b>Limited Access Facilities</b>	<ul style="list-style-type: none"><li>• Limited access</li><li>• Through traffic movements</li><li>• Primary freight routes</li><li>• Guided by FHWA Design Standards for Highways (NHS)</li></ul>
<b>Principal Arterial</b>	<ul style="list-style-type: none"><li>• Through traffic movements</li><li>• Longer distance traffic movements</li><li>• Primary freight routes</li><li>• Access to public transit</li><li>• Pedestrian and bicycle travel</li></ul>
<b>Minor Arterial</b>	<ul style="list-style-type: none"><li>• Connections between local areas and network principal arterials</li><li>• Connections for through traffic between arterial streets or highways</li><li>• Access to public transit and through movements</li><li>• Pedestrian and bicycle travel</li></ul>
<b>Collector</b>	<ul style="list-style-type: none"><li>• Carry traffic with trips ending in a specific area</li><li>• Access to commercial and residential centers</li><li>• Access to public transit</li><li>• Pedestrian and bicycle travel</li></ul>
<b>Local Roads</b>	<ul style="list-style-type: none"><li>• Direct property access—residential and commercial</li><li>• Pedestrian and bicycle travel</li></ul>

## **B.2 Context Classification**

Following context-based design, projects are uniquely planned and designed to be in harmony with the surrounding land use characteristics and the intended uses of the street or highway. To this end, a context-based classification system comprising eight context classifications has been adopted. Figure 1 – 1 Context Classifications describes the context classifications that will determine key design criteria elements. Criteria for limited access facilities are independent of the adjacent land uses; therefore, context classifications shown in Figure 1 – 1 do not apply to these facilities.

For state and federal facilities and planning activities, urban and rural are based on population density gathered from the most recent census and mapped as urban area boundaries. Urban areas are considered to have dense development patterns, while rural areas are considered to have sparse development patterns. The Department FDOT's [Urban Area 1-Mile Buffer Maps](#) identify urban and rural areas based on the census data and regional travel patterns.

Florida cities and counties may use the state and federal urban and rural definitions as guidance. Local comprehensive plans and other studies provide more precise context designations for urban, suburban, and rural areas.

Additional information on context classifications and guidance on the determination of the context classification is provided in the FDOT [Context Classification Document](#). Local governments are encouraged to apply these same definitions to local land areas off the state roadway system. They may also be based upon local context and analysis.

To meet local needs and travel demands, deviations in design criteria may be appropriate for urban streets. **Chapter 3 – Geometric Design, Chapter 8 – Pedestrian Facilities, Chapter 9 – Bicycle Facilities, Chapter 13 – Transit, Chapter 15 – Traffic Calming, Chapter 16 – Residential Street Design, and Chapter 19 – Traditional Neighborhood Development** provide additional information for the design of urban streets.

**Figure 1 – 1 Context Classifications**

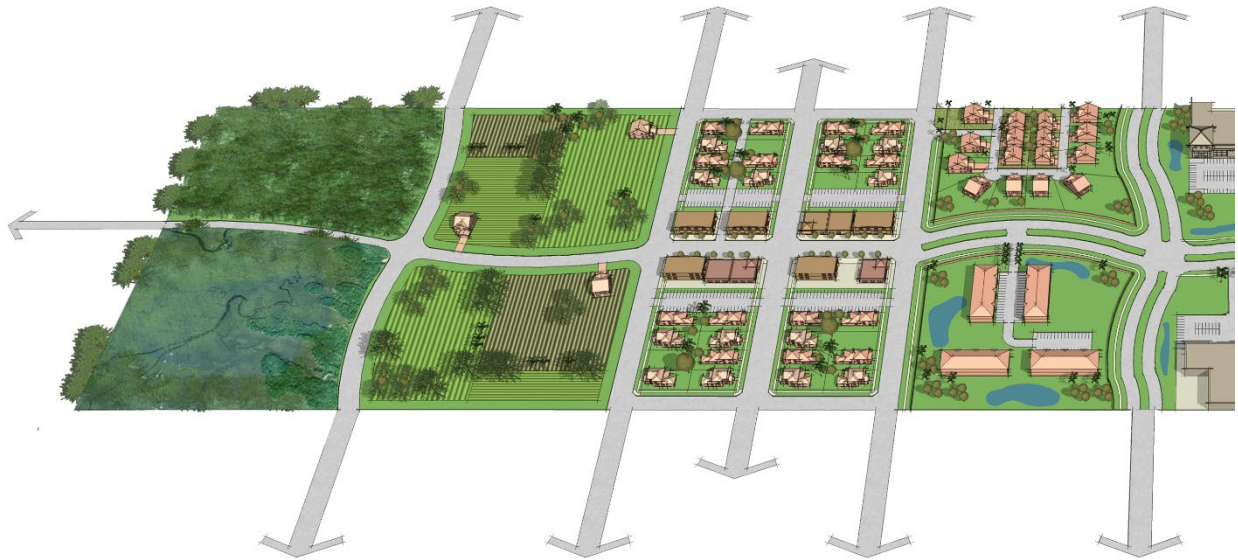

**C1 – Natural**

Lands preserved in a natural or wilderness condition, including lands unsuitable for settlement due to natural conditions.

**C2 – Rural**

Sparsely settled lands; may include agricultural land, grassland, woodland, and wetlands.

**C2T – Rural Town**

Small concentrations of developed areas immediately surrounded by rural and natural areas; includes many historic towns.

**C3R – Suburban Residential**

Mostly residential uses within large blocks and a disconnected or sparse roadway network.

**Figure 1 – 1 Context Classifications (continued)**



**C3C – Suburban Commercial**

Mostly non-residential uses with large building footprints and large parking lots. Buildings are within large blocks and a disconnected or sparse roadway network.

**C4 – Urban General**

Mix of uses set within small blocks with a well-connected roadway network. May extend long distances. The roadway network usually connects to residential neighborhoods immediately along the corridor or behind the uses fronting the roadway.

**C5 – Urban Center**

Mix of uses set within small blocks with a well-connected roadway network. Typically concentrated around a few blocks and identified as part of the community, town, or city of a civic or economic center.

**C6 – Urban Core**

Areas with the highest densities and with building heights typically greater than four floors. Many are regional centers and destinations. Buildings have mixed uses, are built up to the roadway, and are within a well-connected transportation network.



## **B.3 Design Speed**

See **Chapter 3, Section C.1 Design Speed** for information on establishing appropriate design speeds.

## **C CONSIDERATIONS FOR DESIGN**

The following criteria ~~shall~~<sup>should</sup> be considered and resolved in the initial planning and design of streets and highways. The criteria are not listed in order of priority, and the weighting of each criterion should be based on the context of a project, the available resources, and the users.

### **C.1 Safety**

Functional and context classification play an important role in setting expectations and measuring outcomes for safety. Since agencies consider the type of street or highway in evaluating the significance of crash rates, classification can be used as part of evaluating relative safety and the implementation of safety improvements and programs.

### **C.2 Economic Constraints**

In determining the benefit/cost ratio for any proposed facility, the economic evaluation should go beyond the actual expenditure of highway funds and the capacity and efficiency of the facility. Overall costs and benefits of various alternatives should include an evaluation of all known environmental, community, and social impacts and the quality and cost of the project.

Allocation of sufficient funds for obtaining the proper corridor and adequate right of way and alignment should receive the initial priority. Future acquisition of additional right of way and major changes in alignment are often economically prohibitive. This can result in substandard streets and highways that don't support the community's vision. Reconstruction or modification under traffic may be expensive, inconvenient, or hazardous to the user. This increase in costs, hazards, and inconvenience can be limited by initial development of quality facilities.

## C.3 Access Requirements

Degree and type of access permitted on a given facility is dependent upon its intended function and context and should conform to the guidelines in **Chapter 3 – Geometric Design**. Reasonable access control must be exercised to allow a street or highway to fulfill its function. The proper layout of the highway network and the utilization of effective land use controls (~~Chapter 2 – Land Development~~) can provide the basis for regulating access.

## C.4 Measures of Level of Service

Level of service (LOS) is essentially a measure of the quality of the operating characteristics of a street or highway for each travel mode. Factors involved in determining the level of service include speed and safety, as well as travel time; traffic conflicts and interruptions; freedom to maneuver; convenience and comfort; and operating costs. Level of service is also dependent upon actual traffic volume and composition of traffic (motor vehicles, trucks, transit, bicyclists, and pedestrians).

The [Highway Capacity Manual, 6<sup>th</sup> Edition](#) provides further information on assessing the traffic and environmental effects of highway projects.

## C.54 Maintenance Capabilities

Planning and design of streets and highways should include provisions for the performance of required maintenance. The planning of the expected maintenance program should be coordinated with the initial highway design to ensure maintenance activities may be conducted without excessive traffic conflicts or hazards.

## C.65 Utility and Transit Operations

Utility accommodation within rights of way is generally considered to be in the public's best interest, since rights of way frequently offer the most practical engineering, construction, and maintenance solutions for utility service to businesses and residences. Utility and transit facility locations should be carefully chosen to optimize operations and safety of the transportation facility. Additional information on the design of transit facilities can be found in **Chapter 13 – Transit**.

## **C.76** Emergency Response

Development of an effective emergency response program is dependent upon the nature of the highway network and the effectiveness of the operation of the system. Provisions for emergency access and communication should be considered in the initial planning and design of all streets and highways. Local emergency response personnel should be included in primary activities.

## **C.87** Environmental Impact

Construction and operation of streets and highways frequently produces an adverse effect upon the environment. Early consideration and resolution of environmental issues can avoid costly delays and modifications that may compromise the quality and efficiency of operation. Specific topics often encountered include the following:

- Air Quality
- Coastal Zone Resources
- Farmland
- Floodplains
- Hazardous Waste and Brownfields
- Noise
- Roadside vegetation
- Safe Drinking Water Act
- Water Quality
- Watersheds Management
- Wetlands
- Wild and Scenic Rivers and Wilderness Areas
- Wildlife and Threatened and Endangered Species
- Wildlife, Habitat and Ecosystems

## **C.98** Community and Social Impact

Quality and value of a community is directly influenced by the layout and design of

streets and highways. Quality of the network determines the freedom and efficiency of movement. Inadequate design of the network and poor land use practices can lead to undesirable community separation and deterioration. Specific design of streets and highways has a large effect upon the overall aesthetic value which is important to the motorist and resident. When using federal funds for transportation projects, the following considerations should be addressed:

- Corridor Preservation
- Historical and Archaeological Preservation
- Scenic Byways
- [Section 4 \(f\)](#) (parks, refuges, and historic sites)
- [Section 6 \(f\)](#) properties
- Visual Impacts

## **D LANE REPURPOSING**

A lane repurposing project reallocates travel lane(s) to achieve safety, economic development, and mobility for all users. This section serves as a resource for local transportation agency planners and engineers to analyze potential lane repurposing projects and includes the potential factors to be considered prior to design and implementation.

A typical goal for lane repurposing is better managing motor vehicular traffic to make the area more amenable to people who walk/bicycle or at-risk populations, such as children and older adults. A local government may want to create an exclusive lane for transit service. For lane repurposing projects that involve facilities for transit-related services, additional discussion and coordination with their respective transit agencies should take place as early as possible.

All lane repurposing projects must comply with **Section 334.61 F.S.**

Lane repurposing on the Strategic Intermodal System (SIS) will not be considered.

The FDOT [Lane Repurposing Guidebook](#) provides additional information and tools on how to implement lane repurposing projects on the State Highway System. This document also provides useful information to locals for additional guidance.

## **E LAND DEVELOPMENT**

Development controls are needed to aid in the establishment of safe streets and highways that will retain their efficiency and economic worth. There may be legal, social, and economic challenges in land use controls. Proper coordination among the public, various governmental bodies, and public transit and highway agencies can provide solutions to many of these challenges. Implementation of responsible land use and development regulations along with intergovernmental respect for the goals and objectives of each, will promote a high-quality long-term transportation network.

Land development practices should promote high quality street networks that provide interconnectivity and access control. The street network shall be designed for the safety of all road users – pedestrians, bicyclists, transit, and motor vehicle operators and passengers.

The design of the street network and features shall be consistent with the desired context and meet the criteria in this Manual. Context based street design incorporates the following elements:

- Streets are sized and detailed to equitably serve the needs of the intended road users and support target speed.
- Flow patterns are designed to interconnect neighborhoods while discouraging through motorized traffic on local street networks.
- Sufficient right of way is provided, including space allocations for stormwater, utilities, signing and lighting.
- Public transit is supported through a high level of connectivity and attractive facilities (stops, shelters, hubs).
- Energy, infrastructure, and automobile use is reduced through a compact form.
- Provides for aesthetic and environmental compatibility.
- Building size and character spatially define streets and squares.

### **E.1 Development Types and Guidelines**

There are many variables involved in land development. The following principles and guidelines should be utilized in the design of the road network, in the control

of access, and in the land-use controls and space allocation that would affect vehicular and pedestrian use.

### **E.1.a Conventional Suburban Design**

This development type was common practice through the 20<sup>th</sup> century. It is characterized by automobile-dominant design and segregated land uses. The street patterns channel local traffic onto collector and arterial streets to reach most destinations. Although destinations are oftentimes adjacent to one another, this conventional suburban design does not typically connect to them directly. This makes walking an inefficient form of transportation in this development type.

### **E.1.b Traditional Neighborhood Design (TND)**

This refers to the development or redevelopment of a neighborhood or town using traditional town planning principles. Projects should include a range of housing types and commercial establishments, a network of well-connected streets and blocks, civic buildings, and public spaces, and include other uses such as stores, schools, and worship within walking distances of residences. TND communities rely on a strong integration of land use and transportation.

### **E.1.c Transit-Oriented Design (TOD)**

This development type is a compact, mixed use area within one half mile of a transit stop or station that is characterized by streetscapes and an urban form oriented to pedestrians to promote walking trips to stations and varied other uses within station areas. Transit-supportive development enables citizens to use a variety of transportation modes for at least one or more of their daily trips between home, work, shopping, school, or services. These concepts are often called “new urbanism”.

For more information on Conventional Suburban, TND and TOD, refer to the [21st Century Land Development Code](#) and ~~FDOT's [FDOT's Traditional Neighborhood Development Handbook \(2011\)](#)~~ [Traditional Neighborhood Development Handbook \(2011\)](#).

## E.2 Space Allocation

The provisions for adequate space and proper location of various activities is essential to promote safety and efficiency. The following guidelines should be utilized in land use:

- Adequate corridors and space should be considered for utilities. Utility locations should be carefully chosen to minimize interference with the operation of the streets, highways, and bicycle and pedestrian facilities.
- Adequate space for drainage facilities should be provided. Open drainage facilities should be located well clear of the traveled way.
- Right of way and setback requirements should be adequate to provide ample sight distance at all intersections.
- Space allocation for street lighting (existing or planned) should be incorporated into the initial plan. Supports for this lighting should be located outside of the required clear zone unless they are clearly of a breakaway type, or are guarded by adequate protective devices.
- Sufficient right of way should be provided for future widening, modification, or expansion of the street and highway network.
- Adequate space for desired or required landscaping, shade trees, and greenways should be provided.
- Adequate space for appropriate public transit facilities should be provided.

## E.3 Access Control

The utilization of proper control over access is one of the most effective and economical means for maintaining the safety and utility of streets and highways. The following principles should be utilized in the formation of land use controls for managing access:

- The standards presented in **Chapter 3 – Geometric Design, C.8 Access Control**, should provide the basis for establishing land development criteria for control of access.
- The use of an arterial or major collector as an integral part of the internal circulation pattern on private property should be prohibited.
- Access to sites which generate major traffic (motor vehicular, pedestrian, and bicycle), should be located to provide minimum conflict with other traffic.

These generators include schools, shopping centers, business establishments, industrial areas, entertainment facilities, etc.

- Commercial strip development, with the associated proliferation of driveways, should be eliminated. Vehicular and pedestrian interconnections should be encouraged.
- The spacing and location of access points should be predicated upon reducing conflicts between and among motor vehicles, pedestrians, and bicyclists. Crossing and left turn maneuvers may be controlled by continuous median separation.
- Pedestrian access should be provided, with frequent opportunities for crossings.

## **E.4 Control Techniques**

The implementation of a sound highway transportation plan requires certain controls. A logical network design, adequate access controls, and proper land use controls are dependent upon and foster proper land development practices. Techniques that may be utilized to establish these necessary controls include the following:

### **E.4.a Right of Way Acquisition**

The acquisition of sufficient right of way is essential to allow for the construction of streets and highways as specified in this manual. The provision of sufficient space for travel lanes, intersections, bicycle, pedestrian and transit facilities, landscaping, shade trees, buffer zones, drainage facilities, and future expansion is necessary to develop and maintain safe streets and highways.

### **E.4.b Regulatory Authority**

The regulatory authority of local highway agencies (and other related agencies) should be sufficient to implement the necessary land use controls. The following general regulatory requirements and specific areas of control should be considered as minimum:

#### **E.4.b.1 General Regulatory Requirements**

The necessary elements for achieving the following transportation



# DRAFT

goals should be incorporated into all land use and zoning ordinances:

- General highway transportation plans should be created and implemented.
- Determination and acquisition of transportation corridors for future expansions is essential.
- Development plans clearly showing all street and highway layouts, transit facilities, pedestrian and bicycle facilities, and utility corridors should be required. The execution of these plans should be enforceable.
- Development plans, building permits, and zoning should be reviewed by the appropriate agency.

## **E.4.b.2 Specific Control**

Specific areas of control necessary to develop adequate and efficient roadways include the following:

- Land use control and development regulations
- Control of access
- Driveway design
- Street and highway layouts
- Location of vehicular and pedestrian generators
- Location of transit, pedestrian, and bicycle facilities
- Right of way and setback requirements for sight distances and clear zone
- Provisions for drainage

## **E.5 Contracts and Agreements**

Where land purchase or regulatory authority is not available or appropriate, the use of contractual arrangements or agreements with individuals can be beneficial. Negotiations with developers, builders, and private individuals should be used, where appropriate, to aid in the implementation of the necessary controls.

# DRAFT

## E.6 Education

Education of the public, developers, and governmental bodies can be beneficial in promoting proper land development controls. The need for future planning, access control, and design standards should be clearly and continuously emphasized. Successful solidification of the cooperation of the public and other governmental bodies depends upon clear presentation of the necessity for reasonable land development controls.

## **FD OPERATION**

The concept of operating the existing street and highway network as a system is essential to promote safety, efficiency, mobility, and economy. This requires comprehensive planning and coordination of all activities on each street and highway. These activities would include maintenance, construction, utility operations, public transit operations, traffic control, and emergency response operations. The behavior of travelers should be considered as an integral part of the operation of streets and highways. Coordination of the planning and supervision of each activity on each facility is necessary to achieve safety and efficient operation of the total system.

### **FD.1 Policy**

Each transportation agency with general responsibility for existing streets and highways should establish and maintain an operations department. Each existing street or highway should be assigned to the jurisdiction of the operations department. The operations department shall be responsible for planning, supervising, and coordinating all activities affecting the operating characteristics of the system under its jurisdiction.

### **FD.2 Objectives**

The primary objective of an operations department shall be to maintain or improve the operating characteristics of the system under its jurisdiction. These characteristics include safety, capacity, and level of service. The preservation of the function of each facility, which would include access control, is necessary to maintain these characteristics and the overall general value of a street or highway.

### **FD.3 Activities**

The achievement of these objectives requires the performance of a variety of coordinated activities by the operations department. The following activities should be considered as minimal for promoting the safe and efficient operation of a system.

## **DE.3.a Maintenance and Reconstruction**

Maintaining or upgrading the quality of existing facilities is an essential factor in preserving desirable operating characteristics. The planning and execution of maintenance and reconstruction activity on existing facilities must be closely coordinated with all other operational activities and, therefore, should be under the general supervision of the operations department.

All maintenance work should be conducted in accordance with the requirements of **Chapter 10 – Maintenance and Resurfacing**. The priorities and procedures utilized should be directed toward improvement of the existing system. The standards set forth in this Manual should be used as guidelines for establishing maintenance and reconstruction objectives. All maintenance and reconstruction projects should be planned to minimize traffic control conflicts and hazards.

## **FD.3.b Work Zone Safety**

An important responsibility of the operations department is the promotion of work zone safety on the existing system. The planning and execution of maintenance, construction, and other activities shall include provisions for the safety of motorists, bicyclists, pedestrians, and workers. All work shall be conducted in accordance with the requirements presented in **Chapter 11 – Work Zone Safety and Mobility**.

## **FD.3.c Traffic Control**

Traffic engineering is a vital component of highway operations. The planning and design of traffic control devices should be carried out in conjunction with the overall design of the street or highway and highway user. The devices and procedures utilized for traffic control should be predicated upon developing uniformity throughout the system and compatibility with adjacent jurisdictions.

A primary objective to be followed in establishing traffic control procedures is the promotion of safe, orderly traffic flow. The cooperation of police agencies and coordination with local transit providers is essential for the achievement of this objective. Traffic control during maintenance, construction, utility, or emergency response operations should receive special consideration.

### **FD.3.d Emergency Response**

The emergency response activities (i.e., emergency maintenance and traffic control) of the operations department should be closely coordinated with the work of police, fire, ambulance, medical, and other emergency response agencies. The provisions for emergency access and communications should be included in the initial planning for these activities.

### **FD.3.e Coordination and Supervision**

Coordination and supervision of activities on the system should include the following:

- Supervision and/or coordination of all activities of the operations department and other agencies to promote safe and efficient operation
- Coordination of all activities to provide consistency within a given jurisdiction
- Coordination with adjacent jurisdictions to develop compatible highway systems
- Coordination with other transportation modes to promote overall transportation efficiency

### **FD.3.f Inspection and Evaluation**

The actual operation of streets and highways provides valuable experience and information regarding the effectiveness of various activities. Each operations department should maintain a complete inventory of its system and continuously inspect and evaluate the priorities, procedures, and techniques utilized in all activities on the existing system under its jurisdiction. Activities by other agencies, as well as any agency, should be subjected to this supervision.

Promotion of transportation safety should be aided by including a safety office (or officer) as an integral part of the operations department. Functions of this office would include the identification and inventory of hazardous locations and procedures for improving the safety characteristics of highway operations.

# DRAFT

Results of this inspection and evaluation program should be utilized to make the modification necessary to promote safe and efficient operation. Feedback for modifying design criteria should be generated by this program. Experience and data obtained from operating the system should be utilized as a basis for recommending regulatory changes. Cooperation of legislative, law enforcement, and regulatory agencies is essential to develop the regulation of vehicles, driver behavior, utility, emergency response activities, and the access land use practices necessary for the safe and efficient operation of the highway system.

## **GE** REFERENCES FOR INFORMATIONAL PURPOSES

- [Florida Transportation Plan](http://floridatransportationplan.com/)  
<http://floridatransportationplan.com/>
- [Florida Growth Management and Comprehensive Planning Laws \(DEO~~OE~~\)](http://www.floridajobs.org/community-planning-and-development)  
<http://www.floridajobs.org/community-planning-and-development>
- [1000 Friends of Florida](http://www.1000fof.org/)  
<http://www.1000fof.org/>
- [Florida Metropolitan Planning Organization Advisory Council \(MPOAC\)](http://www.mpoac.org/)  
<http://www.mpoac.org/>
- [Understanding Sprawl, A Citizen's Guide](https://www.osti.gov/etdeweb/biblio/20414909)  
<https://www.osti.gov/etdeweb/biblio/20414909>
- [Traditional Neighborhood Development Handbook](http://www.fdot.gov/roadway/FloridaGreenbook/TND-Handbook.pdf)  
<http://www.fdot.gov/roadway/FloridaGreenbook/TND-Handbook.pdf>

~~Design criteria are established for transportation projects to ensure that they provide safe, economical, and fully functional multimodal transportation facilities. Various Department FDOT publications contain information on procedures, criteria, and standards for guiding and controlling design and construction activities. There are many local, state, and federal laws and rules that may impact the design of a project. These laws and rules are referenced in the publications when the Department is aware of them.~~

~~For situations where specific design standards or criteria cannot be found in the Department FDOT publications, current approved technical publications such as [\*AASHTO's Policy on Geometric Design of Highways and Streets \(2011\)\*](#) should be used as design guidelines. Local agencies must ensure that project designs meet or~~

# DRAFT

~~exceed the referenced design criteria and that the standards developed from acceptable guidelines are appropriate for the proposed facility.~~

~~The following publications provide further information and guidance for Roadway and Bridge/Structure designs:~~

~~— FDOT Design Plans Preparation Manual, Volume I (Topic No. 625-000-0027) and Volume II (Topic No. 625-000-008)  
<http://www.fdot.gov/roadway/FDM/>~~

~~•~~

~~— Design Standard Plans for Road and Bridge Constructions (Standard Indexes) (Topic No. 625-010-003)  
<http://www.fdot.gov/design/standardplans/>~~

~~• FDOT Standard Specifications for Road and Bridge Construction~~

~~— Project Development and Environment Manual Part 1 and Part 2 (Topic No. 650-000-001)  
<http://www.fdot.gov/environment/pubs/pdeman/pdeman1.shtm>~~

~~• <http://www.dot.state.fl.us/rddesign/DesignStandards/Standards.shtm>~~

~~• Manual of Uniform Minimum Standards for Design, Construction and Maintenance for Streets and Highways (Florida Greenbook) (Topic No. 625-000-015)  
<http://www.dot.state.fl.us/rddesign/FloridaGreenbook/FGB.shtm>~~

~~• A Policy on Geometric Design of Highways and Streets, 6th Edition (AASHTO Green Book) (AASHTO Bookstore GDHS-6)  
[https://bookstore.transportation.org/collection\\_detail.aspx?ID=110](https://bookstore.transportation.org/collection_detail.aspx?ID=110)~~

~~• FDOT Standard Specifications for Road and Bridge Construction  
<http://www.dot.state.fl.us/specificationsoffice/Implemented/SpecBooks/default.shtm>~~

~~• AASHTO LRFD Bridge Design Specifications, Customary U.S. Units, 6th Edition (AASHTO Bookstore LRFDUS-6-M)  
[https://bookstore.transportation.org/item\\_details.aspx?id=1924](https://bookstore.transportation.org/item_details.aspx?id=1924)~~

~~• FDOT Structures Manual (Topic No. 625-020-018)  
<http://www.dot.state.fl.us/structures/StructuresManual/CurrentRelease/StructuresManual.shtm>~~

# DRAFT

- ~~FDOT Facilities Design Manual (Topic No. 625-020-016)  
<http://www.dot.state.fl.us/projectmanagementoffice/Publications/default.shtm>~~
- ~~Florida Intersection Design Guide  
<http://www.dot.state.fl.us/rddesign/FIDG-Manual/FIDG.shtm>~~
- ~~NCHRP Report 672—Roundabouts: An Informational Guide, 2<sup>nd</sup> Edition  
[http://onlinepubs.trb.org/onlinepubs/nchrp/nchrp\\_rpt\\_672.pdf](http://onlinepubs.trb.org/onlinepubs/nchrp/nchrp_rpt_672.pdf)~~
- ~~AASHTO Highway Safety Manual, 1st Edition (AASHTO Bookstore HSM-1)  
<https://bookstore.transportation.org/>~~
- ~~[https://bookstore.transportation.org/collection\\_detail.aspx?ID=33](https://bookstore.transportation.org/collection_detail.aspx?ID=33)~~
- ~~Local Agency Program Manual (Topic No. 525-010-300)  
[http://www.dot.state.fl.us/projectmanagementoffice/lap/LAP\\_TOC.shtm](http://www.dot.state.fl.us/projectmanagementoffice/lap/LAP_TOC.shtm)~~
- ~~Project Development and Environmental Manual Part 1 and Part 2 (Topic No. 650-000-001)  
<http://www.dot.state.fl.us/emo/pubs/pdeman/pdeman1.shtm>~~
- ~~Rigid Pavement Design Manual (Topic No. 625-010-006)  
<http://www.dot.state.fl.us/rddesign/PM/Publications.shtm>~~
- ~~Flexible Pavement Design Manual (Topic No. 625-010-002)  
<http://www.dot.state.fl.us/rddesign/PM/publicationS.shtm>~~
- ~~FDOT Drainage Manual (Topic No. 625-040-002)  
<http://www.dot.state.fl.us/rddesign/Hydraulics/ManualsandHandbooks.shtm>~~
- ~~Soils and Foundations Handbook  
<http://www.dot.state.fl.us/structures/DocsandPubs.shtm>~~
- ~~Standard Highway Signs (FHWA)  
<http://mutcd.fhwa.dot.gov/ser-shs-millennium.htm>~~
- ~~Manual on Uniform Traffic Control Devices for Streets and Highways, 2009 Edition  
<http://mutcd.fhwa.dot.gov/kno-2009r1r2.htm>~~
- ~~Roadway Lighting Design Guide (AASHTO Bookstore GL-6)  
[https://bookstore.transportation.org/item\\_details.aspx?id=320](https://bookstore.transportation.org/item_details.aspx?id=320)~~
- ~~AASHTO Standard Specifications for Structural Supports for Highway Signs, Luminaires, and Traffic Signals, 6th Edition (AASHTO Bookstore LTS-6)  
[https://bookstore.transportation.org/collection\\_detail.aspx?ID=126](https://bookstore.transportation.org/collection_detail.aspx?ID=126)~~
- Highway Functional Classification: Concepts, Criteria and Procedures, 2013 Edition (FHWA)  
[http://www.fhwa.dot.gov/planning/processes/statewide/related/highway\\_functi](http://www.fhwa.dot.gov/planning/processes/statewide/related/highway_functi)



# DRAFT

## [onal classifications/section00.cfm](#)

- ~~Highway Capacity Manual 2010 (Transportation Research Board) (TRB Bookstore HCM10)~~  
~~<http://books.trbbookstore.org/hcm10.aspx>~~
- ~~Quality/Level of Service Handbook (FDOT, 2020~~13~~)~~  
~~<https://www.fdot.gov/planning/systems/documents/sm/default.shtm>~~~~<http://www.fdot.gov/planning/systems/programs/sm/los/default.shtm>~~
- ~~<http://www.dot.state.fl.us/planning/systems/programs/sm/los/default.shtm>~~
- Manual on Uniform Traffic Studies (Topic No. 750-020-007)  
~~<https://www.fdot.gov/docs/default-source/traffic/TrafficServices/Studies/MUTS/MUTS-Final-01.2016.pdf>~~~~[https://fdotwww.blob.core.windows.net/sitefinity/docs/default-source/traffic/traffic-services/studies/muts/new-muts-2021-and-forms/2021-muts-compiled-20220420.pdf?sfvrsn=141a4970\\_0](https://fdotwww.blob.core.windows.net/sitefinity/docs/default-source/traffic/traffic-services/studies/muts/new-muts-2021-and-forms/2021-muts-compiled-20220420.pdf?sfvrsn=141a4970_0)~~
- ~~Surveying Procedure (Topic No. 550-030-101)~~  
~~<https://pdl.fdot.gov/api/procedures/downloadProcedure/550-030-101>~~
- ~~Right of Way Mapping Procedure (Topic No. 550-030-015)~~  
~~[http://www.dot.state.fl.us/surveyingandmapping/doc\\_pubs.shtm](http://www.dot.state.fl.us/surveyingandmapping/doc_pubs.shtm)~~

# DRAFT

## CHAPTER 2

### LAND DEVELOPMENT

**THE CONTENTS OF THIS CHAPTER HAVE BEEN REVISED  
AND MOVED TO CHAPTER 1 - PLANNING AND LAND  
DEVELOPMENT**

**~~THIS PAGE INTENTIONALLY LEFT BLANK~~**

~~CHAPTER 2~~

### ~~LAND DEVELOPMENT~~

#### ~~A INTRODUCTION~~

~~A major portion of street and highway construction and reconstruction is a result of land development for residential, commercial, industrial, and public uses. The general land use layout influences, and is controlled by, connections to adjacent road networks with different transportation modes. Techniques, principles, and general layout used for any development also dictate the resulting internal road network. The arrangement and space allocations for this network may determine whether safe, efficient, and economical streets and highways are constructed or reconstructed.~~

~~Land development practices should promote high quality street networks that provide interconnectivity and access control. The street network shall be designed for the safety of all road users — pedestrians, bicyclists, transit, and motor vehicle operators and passengers.~~

~~The design of the street network and features should be consistent with the desired context and meet the criteria in this Manual. Context based street design incorporates the following elements:~~

- ~~• Streets are sized and detailed to equitably serve the needs of the intended road users.~~
- ~~• Building size and character spatially define streets and squares.~~

# DRAFT

- ~~Compact form reduces requirements for energy, infrastructure, and automobile use.~~
- ~~Public transit is supported through a high level of connectivity and attractive facilities (stops, shelters, hubs).~~

# DRAFT

Some development patterns, such as conventional suburban, do not promote the creation of a high quality, accessible street network. To promote the creation of context-sensitive high quality interconnected streets:

- Design for desired/target speeds.
- Design desirable geometry to achieve sufficient sight distance and appropriate cross section (not too wide or too narrow for the context).
- Provide sufficient right of way and space allocations for stormwater, utilities, pedestrian features, and lighting, etc.
- Provide reasonable control of access.

Two of the more recent alternatives to the conventional suburban development patterns include Traditional Neighborhood Development (TND) and Transit Oriented Development (TOD). For more information, refer to [21st Century Land Development Code](#).

Development controls are needed to aid in the establishment of safe streets and highways that will retain their efficiency and economic worth. Provisions for adequate alignment, right of way, setbacks, expansion, and access control are essential.

There may be legal, social, and economic challenges in land use controls. Proper coordination among the public, various governmental bodies, and public transit and highway agencies can provide solutions to many of these challenges. Implementation of responsible land use and development regulations along with intergovernmental respect for the goals and objectives of each, will promote a high quality long term transportation network.

# DRAFT

## B OBJECTIVES

~~Provisions for vehicular and pedestrian safety are important objectives to be considered in land development. Other land development objectives, related to surface transportation, should include the promotion of smooth traffic flow, efficiency, economy, aesthetics, and environmental compatibility of the transportation network.~~

~~General objectives for land development that should be followed to promote good highway design include the following:~~

- ~~• Ensure the function of each street and highway meets its intended purpose and context~~
- ~~• Provide for logical and energy efficient interconnected street network and flow patterns~~
- ~~• Reduce trip lengths~~
- ~~• Encourage the appropriate vehicular speed~~
- ~~• Reduce traffic conflicts to a minimum and eliminate confusion~~
- ~~• Apply safe geometric design principles~~
- ~~• Promote bicycle and pedestrian use through connectivity and access~~
- ~~• Provide for future modifications and expansion~~
- ~~• Provide for aesthetic and environmental compatibility~~
- ~~• Develop economic design, construction, and maintenance strategies~~
- ~~• Provide for public transit facilities~~
- ~~• Provide accessibility for persons with disabilities~~

# DRAFT

## C PRINCIPLES AND GUIDELINES

There are many variables involved in land development; therefore, specific standards and requirements for land use and road network layouts cannot always be applied. Use of sound principles and guidelines can, however, aid in meeting the objectives of a better road network. Proper planning and design of the development layout are necessary to provide a satisfactory road network and to allow for the construction of safe roadways. The following principles and guidelines should be utilized in the design of the road network, in the control of access, and in the land use controls and space allocation that would affect vehicular and pedestrian use.

### C.1 Development Types and Area Types

#### C.1.a Conventional Suburban Design

This development type was common practice through the 20<sup>th</sup> century. It is characterized by automobile-dominant design, segregated land uses, and roadways that are often designed primarily for the use of the automobile. The street patterns channel local traffic onto collector streets and roads to reach most destinations. Although destinations are oftentimes adjacent to one another, this conventional suburban design does not typically connect to them directly. This makes walking an inefficient form of transportation in this development type.

#### C.1.b Traditional Neighborhood Design (TND)

This development type is a development alternative that promotes a strong integration of land use and transportation. For further information on TND, refer to Chapter 19 of this Manual.

#### C.1.c Transit-Oriented Design (TOD)

This development type is defined as a compact, mixed use area within one half mile of a transit stop or station that is designed to maximize walking trips and access to transit. They also are characterized by streetscapes and an urban form oriented to pedestrians to promote walking trips to stations and varied other uses within station areas.

# DRAFT

Further information on TOD can be found on the Department's website:  
<http://www.fltod.com/>.

# DRAFT

~~Transit-supportive planning and development rethinks land-use and development patterns so that communities may be effectively served by a balanced transportation system. Transit-supportive development enables citizens to use a variety of transportation modes for at least one or more of their daily trips between home, work, shopping, school, or services. These concepts are often called new urbanism to distinguish that form of urban design practice.~~

~~For more information on Conventional Suburban, TND and TOD, refer to the 21st Century Land Development Code and Traditional Neighborhood Development Handbook.~~

## ~~C.2 Network Design~~

~~The general layout of the road network establishes the traffic flow patterns and conflicts, thereby determining the basic safety and efficiency criteria. The design of the road network should be based on the following principles:~~

~~The layout of street and highway systems should be logical and easily understood by the user.~~

~~The design and layout of all streets and highways should clearly indicate their function.~~

~~Local circulation patterns should be compatible with adjacent areas.~~

~~Flow patterns should be designed to interconnect neighborhoods while discouraging through motorized traffic on local street networks.~~

~~Elements in the local circulation should be adequate to avoid the need for extensive traffic controls.~~

~~Typically, some streets are designed to accommodate a higher speed than the posted speed, which may cause enforcement problems and can have a negative safety impact on the circulation within an urban or residential network. In other situations, controlling speed levels is important in areas of concentrated pedestrian activities, areas with narrow right of way, areas with numerous access points, and on-street~~



# DRAFT

~~parking. Local authorities may elect to use traffic calming design features which are presented in *Chapter 15 – Traffic Calming*.~~

~~The internal circulation should be sufficient to provide reasonable travel distance for local trips.~~

~~The road network should be compatible with other transportation modes such as mass transit and pedestrian and bicycle facilities. Conflicts between different modes (particularly with pedestrian and bicycle traffic) should be kept to a minimum.~~

~~The road network layout should be designed to reduce conflicts with pedestrians, eliminate substantial speed differentials and hazardous turning and crossing maneuvers.~~

~~Generally the number of intersections should meet user needs, support development patterns, and traffic flow and connectivity requirements.~~

~~Roundabouts should be evaluated for installation at new intersections. Consideration should be given to redesigning existing intersections as roundabouts. For further information on roundabouts, refer to the *National Cooperative Highway Research Project (NCHRP) 672* and *674*.~~

~~One-way streets are an option to consider where feasible.~~

~~Streets should be designed to limit vehicle speeds (length, width, alignment, and intersections).~~

~~The network should be designed to reduce the number of crossings and left turn maneuvers that are required.~~

## ~~C.3 Access Control~~

~~The standards and requirements presented in *Chapter 3 – Geometric Design*, are necessary to maintain safe and efficient streets and highways. Failure to provide adequate control of access has seriously damaged many existing roadways. Unrestricted access to major collectors and arterials has dramatically reduced their capacity and~~

# DRAFT

~~general economic value. The safety characteristics of these facilities have similarly been diminished by significantly increasing the number of vehicular, pedestrian, and bicycle traffic conflicts.~~

~~The utilization of proper control over access is one of the most effective and economical means for maintaining the safety and utility of streets and highways. The procedures and controls used for land development significantly affect access control. The following principles should be utilized in the formation of land use controls for limiting access:~~

~~The standards presented in *Chapter 3 – Geometric Design, C.8 Access Control*, should provide the basis for establishing land development criteria for control of access.~~

~~The use of an arterial or major collector as an integral part of the internal circulation pattern on private property should be prohibited.~~

~~The intersection of private roads and driveways with arterials or major collectors should be strictly controlled.~~

~~Access to sites which generate major traffic (vehicular, pedestrian, and bicycle), should be located to provide the minimum conflict with other traffic. These generators include schools, shopping centers, business establishments, industrial areas, entertainment facilities, etc.~~

~~Commercial strip development, with the associated proliferation of driveways, should be eliminated. Vehicular and pedestrian interconnections should be encouraged.~~

~~The function of all streets and highways should be preserved by the application of the appropriate access controls.~~

~~The spacing and location of access points should be predicated upon reducing the total traffic and pedestrian conflict.~~

~~Hazardous maneuvers should be restricted by access controls. For example, crossing and left turn maneuvers may be controlled by continuous median separation. Pedestrian access should be allowed~~

# DRAFT

~~at appropriate intervals. Medians with waiting space for pedestrians crossing the street are often necessary.~~

## ~~C.4 Land Use Controls and Space Allocation~~

~~The provisions for adequate space and proper location of various activities is essential to promote safety and efficiency. The following guidelines should be utilized in land use:~~

~~Adequate corridors and space should be considered for utilities. Utility locations should be carefully chosen to minimize interference with the operation of the streets, highways, and sidewalks.~~

~~Adequate space for drainage facilities should be provided. Open drainage facilities should be located well clear of the traveled way.~~

~~Design for pedestrian and bicycle facilities should comply with *Chapter 8 – Pedestrian Facilities* and *Chapter 9 – Bicycle Facilities*.~~

~~Adequate space should be provided for off-street and side-street parking. This is essential in commercial and industrial areas.~~

~~Right of way and setback requirements should be adequate to provide ample sight distance at all intersections.~~

~~Sufficient space should be allocated for the development of adequate intersections, including accessibility for disabled individuals.~~

~~Space allocation for street lighting (existing or planned) should be incorporated into the initial plan. Supports for this lighting should be located outside of the required clear zone unless they are clearly of breakaway type, or are guarded by adequate protective devices. Lighting plans should provide for well-lit, safe waiting and walking areas and shall conform with the provisions of *Chapter 6 – Lighting*.~~

~~Sufficient right of way should be provided for future widening,~~

# DRAFT

~~modification, or expansion of the highway network.~~

~~Adequate corridors for future freeways, High Occupancy Vehicle (HOV) lanes, arterials, or major collectors should be provided.~~

~~Adequate space for desired or required greenways should be provided.~~

~~Adequate space for appropriate public transit facilities should be provided.~~

# DRAFT

## D COORDINATION

There are many demands that can conflict with the development of safe and efficient streets and highways. Meeting the demand for access can negatively impact the capacity of a roadway. Pressure to limit the amount of land dedicated for streets and highways inhibits the construction of an adequate road system. Coordination between highway agencies and other governmental bodies can assist in improving the procedures used in land development. Proper coordination should be solicited from legislative bodies, courts, planning and zoning departments, and transit and other governmental agencies to aid in developing a well-designed highway network. Coordination with transit planners, developers, engineers, architects, contractors, and other private individuals should be a continuous process.

The *Florida Metropolitan Planning Organization Advisory Council (MPOAC)* is a statewide transportation planning and policy organization created by the Florida Legislature pursuant to *Section 339.175(11), Florida Statutes*, to augment the role of individual MPOs in the cooperative transportation planning process. The MPOAC assists MPOs in carrying out the urbanized area transportation planning process by serving as the principal forum for collective policy discussion. Further information on the MPOAC, including links to MPOs, can be found at <http://www.mpoac.org/>.

# DRAFT

## E CONTROL TECHNIQUES

The implementation of a sound highway transportation plan requires certain controls. A logical network design, adequate access controls, and proper land use controls are dependent upon and foster proper land development practices. Techniques that may be utilized to establish these necessary controls include the following:

### E.1 Right of Way Acquisition

The acquisition of sufficient right of way is essential to allow for the construction of adequate streets and highways as specified in Chapter 3 – Geometric Design and Chapter 4 – Roadside Design. The provision of adequate space for clear roadside, sight distance, drainage facilities, buffer zones, intersections, transit, sidewalks, frontage roads, and future expansion is also necessary to develop and maintain safe streets and highways.

### E.2 Regulatory Authority

The regulatory authority of state and local highway agencies (and other related agencies) should be sufficient to implement the necessary land use controls. The following general regulatory requirements and specific areas of control should be considered as minimum:

#### E.2.a General Regulatory Requirements

The necessary elements for achieving the following transportation goals should be incorporated into all land use and zoning ordinances:

General highway transportation plans should be created and implemented.

Determination and acquisition of transportation corridors for future expansions is essential.

Development plans clearly showing all street and highway layouts, transit facilities, pedestrian and bicycle facilities, and utility corridors

# DRAFT

~~should be required. The execution of these plans should be enforceable.~~

~~Development plans, building permits, and zoning should be reviewed by the appropriate agency.~~

~~A safety check of proposed streets and highways should be a required step in the review and acceptance of all development plans.~~

## ~~E.2.b Specific Control~~

~~Specific areas of control necessary to develop adequate and efficient roadways include the following:~~

~~Land use control and development regulations~~

~~Control of access~~

~~Driveway design~~

~~Street and highway layouts~~

~~Location of vehicular and pedestrian generators~~

~~Location of transit, pedestrian, and bicycle facilities~~

~~Right of way and setback requirements for sight distances and clear zone~~

~~Provisions for drainage~~

## ~~E.3 Contracts and Agreements~~

~~Where land purchase or regulatory authority is not available or appropriate, the use of contractual arrangements or agreements with individuals can be beneficial. Negotiations with developers, builders, and private individuals should be used, where appropriate, to aid in the~~

# DRAFT

~~implementation of the necessary controls.~~

## ~~E.4—Education~~

~~Education of the public, developers, and governmental bodies can be beneficial in promoting proper land development controls. The need for future planning, access control, and design standards should be clearly and continuously emphasized. Successful solidification of the cooperation of the public and other governmental bodies depends upon clear presentation of the necessity for reasonable land development controls.~~



# DRAFT

## ~~F REFERENCES FOR INFORMATIONAL PURPOSES~~

~~21<sup>st</sup> Century Land Development Code~~

~~<https://www.planning.org/publications/book/9026709/>~~

~~Florida Transportation Plan~~

~~<http://floridatransportationplan.com/>~~

~~Florida Growth Management and Comprehensive Planning Laws (DOE)~~

~~<http://www.floridajobs.org/community-planning-and-development>~~

~~1000 Friends of Florida~~

~~<http://www.1000fof.org/>~~

~~Florida Metropolitan Planning Organization Advisory Council (MPOAC)~~

~~<http://www.mpoac.org/>~~

~~Understanding Sprawl, A Citizen's Guide~~

~~<http://www.davidsuzuki.org/publications/resources/2003/understanding-sprawl-a-citizens-guide/>~~

~~**Traditional Neighborhood Development Handbook**~~

~~**<http://www.fdot.gov/roadway/FloridaGreenbook/TND-Handbook.pdf>**~~

# DRAFT

## CHAPTER 3 GEOMETRIC DESIGN

A	INTRODUCTION .....	3-1
B	OBJECTIVES .....	3-3
C	DESIGN ELEMENTS .....	3-3
C.1	Design Speed .....	3-3
C.2	Design Vehicles .....	3-6
C.3	Sight Distance .....	3-10
C.3.a	Stopping Sight Distance .....	3-10
C.3.b	Decision Sight Distance .....	3-12
C.3.c	Passing Sight Distance .....	3-14
C.3.d	Intersection Sight Distance .....	3-15
C.4	Horizontal Alignment .....	3-15
C.4.a	General Criteria .....	3-15
C.4.b	Maximum Deflections in Alignment without Curves .....	3-16
C.4.c	Superelevation .....	3-19
C.4.c.1	Rural Highways, Urban Freeways and High Speed Urban Highways .....	3-19
C.4.c.2	Low Speed Urban Roadways .....	3-20
C.4.d	Maximum Curvature/Minimum Radius .....	3-24
C.4.e	Superelevation Transition (superelevation runoffs plus tangent runoff) .....	3-24
C.4.f	Sight Distance on Horizontal Curves .....	3-26
C.4.g	Lane Widening on Curves .....	3-31
C.5	Vertical Alignment .....	3-34
C.5.a	General Criteria .....	3-34
C.5.b	Grades .....	3-34
C.5.c	Vertical Curves .....	3-36
C.6	Alignment Coordination .....	3-42
C.7	Cross Section Elements .....	3-43
C.7.a	Number of Lanes .....	3-43
C.7.b	Pavement .....	3-43

# DRAFT

	C.7.b.1	Pavement Width .....	3-43
	C.7.b.2	Traveled Way Cross Slope (not in superelevation) .....	3-45
C.7.c	Shoulders .....		3-46
	C.7.c.1	Shoulder Width .....	3-46
	C.7.c.2	Shoulder Cross Slope .....	3-48
C.7.d	Sidewalks and Shared Use Paths.....		3-48
C.7.e	Medians.....		3-49
	C.7.e.1	Type of Median.....	3-50
	C.7.e.2	Median Width.....	3-51
	C.7.e.3	Median Slopes.....	3-53
	C.7.e.4	Median Barriers .....	3-53
C.7.f	Islands.....		3-53
	C.7.f.1	Channelizing Islands .....	3-56
	C.7.f.2	Divisional Islands.....	3-61
	C.7.f.3	Refuge Islands.....	3-62
C.7.g	Curbs.....		3-68
C.7.h	Parking .....		3-69
	C.7.h.1	Parallel Parking Lanes .....	3-69
	C.7.h.2	Angle Parking .....	3-71
	C.7.h.3	Cross Slope .....	3-73
	C.7.h.4	ADA Requirements.....	3-73
	C.7.h.5	Parking Restrictions .....	3-74
	C.7.h.6	Signing and Marking .....	3-76
C.7.i	Right of Way .....		3-76
C.7.j	Changes in Typical Section.....		3-77
	C.7.j.1	General Criteria .....	3-77
	C.7.j.2	Lane Deletions and Additions .....	3-77
	C.7.j.3	Preferential Lanes .....	3-77
	C.7.j.4	Structures.....	3-78
		C.7.j.4.(a) Lateral Offset .....	3-78
		C.7.j.4.(b) Vertical Clearance .....	3-79
		C.7.j.4.(c) End Treatment.....	3-79
C.8	Access Control .....		3-79
	C.8.a	Justification .....	3-80

# DRAFT

C.8.b	General Criteria .....	3-80
C.8.b.1	Location of Access Points .....	3-80
C.8.b.2	Spacing of Access Points .....	3-80
C.8.b.3	Restrictions of Maneuvers .....	3-80
C.8.b.4	Auxiliary Lanes .....	3-81
C.8.b.5	Grade Separation .....	3-81
C.8.b.6	Roundabouts .....	3-82
C.8.c	Control for All Limited Access Highways .....	3-82
C.8.d	Control of Urban and Rural Streets and Highways .....	3-83
C.8.e	Land Development .....	3-84
C.9	Intersection Design.....	3-84
C.9.a	General Criteria .....	3-85
C.9.b	Sight Distance.....	3-86
C.9.b.1	General Criteria .....	3-86
C.9.b.2	Obstructions to Sight Distance .....	3-87
C.9.b.3	Stopping Sight Distance.....	3-88
C.9.b.3.(a)	Approach to Stops.....	3-88
C.9.b.3.(b)	On Turning Roads.....	3-89
C.9.b.4	Sight Distance for Intersection Maneuvers .....	3-91
C.9.b.4.(a)	Driver's Eye Position and Vehicle Stopping Position .....	3-95
C.9.b.4.(b)	Design Vehicle .....	3-95
C.9.b.4.(c)	Case B1 - Left Turns from the Minor Road .....	3-96
C.9.b.4.(d)	Case B2 - Right Turns From the Minor Road and Case B3 – Crossing Maneuver From the Minor Road .....	3-96
C.9.b.4.(e)	Intersections with Traffic Signal Control (AASHTO Case D) .....	3-97
C.9.b.4.(f)	Intersections with All-Way Stop Control (AASHTO Case E) .....	3-98
C.9.b.4.(g)	Left Turns from the Major Road (AASHTO Case F) .....	3-98
C.9.b.4.(h)	Intersection Sight Distance References .....	3-98
C.9.c	Auxiliary Lanes .....	3-100
C.9.c.1	Merging Maneuvers .....	3-100

# DRAFT

	C.9.c.2	Acceleration Lanes.....	3-102
	C.9.c.3	Exit Lanes .....	3-106
	C.9.c.4	Auxiliary Lanes at Intersections .....	3-109
		C.9.c.4.(a) Widths of Auxiliary Lanes .....	3-109
		C.9.c.4.(b) Lengths of Auxiliary Lanes for Deceleration .....	3-109
		C.9.c.4.(c) Lengths of Auxiliary Lanes for Acceleration.....	3-113
	C.9.d	Turning Roadways at Intersections.....	3-114
		C.9.d.1 Design Speed .....	3-114
		C.9.d.2 Horizontal Alignment .....	3-114
		C.9.d.3 Vertical Alignment .....	3-115
		C.9.d.4 Cross Section Elements.....	3-116
	C.9.e	At Grade Intersections.....	3-119
		C.9.e.1 Turning Radii .....	3-119
		C.9.e.2 Cross Section Correlation .....	3-119
		C.9.e.3 Median Openings .....	3-120
		C.9.e.4 Channelization.....	3-120
	C.9.f	Driveways .....	3-120
	C.9.g	Interchanges .....	3-121
	C.9.h	Clear Zone .....	3-122
C.10		Other Design Factors .....	3-123
	C.10.a	Pedestrian Facilities .....	3-123
		C.10.a.1 Policy and Objectives - New Facilities.....	3-123
		C.10.a.2 Accessibility Requirements .....	3-123
		C.10.a.3 Sidewalks and Shared Use Paths .....	3-123
	C.10.b	Bicycle Facilities .....	3-125
	C.10.c	Bridge Design Loadings .....	3-126
	C.10.d	Dead End Streets and Cul-de-Sacs.....	3-126
	C.10.e	Bus Benches and Transit Shelters.....	3-126
	C.10.f	Traffic Calming.....	3-126
C.11		Reconstruction.....	3-127
		C.11.a Introduction .....	3-127
		C.11.b Evaluation of Streets and Highways .....	3-127
		C.11.c Priorities .....	3-128

# DRAFT

Topic # 625-000-015  
Manual of Uniform Minimum Standards  
for Design, Construction and Maintenance  
for Streets and Highways

---

~~2018~~2023

C.12	Design Exceptions.....	3-130
C.13	Very Low-Volume Local Roads (ADT $\leq$ 400) .....	3-130
C.13.a	Bridge Width .....	3-130
C.13.b	Roadside Design .....	3-130

# DRAFT

## TABLES

Table 3 – 1	Minimum and Maximum Design Speed (mph) .....	3-5
Table 3 – 2	Design Vehicles.....	3-7
Table 3 – 3	Minimum Turning Radii of Design Vehicles .....	3-9
Table 3 – 4	Minimum Stopping Sight Distance.....	3-11
Table 3 – 5	Decision Sight Distance .....	3-13
Table 3 – 6	Minimum Passing Sight Distance .....	3-15
Table 3 – 7	Maximum Deflection Angle Through Intersection .....	3-18
Table 3 – 9	Length of Compound Curves on Turning Roadways.....	3-19
Table 3 – 10	Superelevation Rates for Rural Highways, Urban Freeways and High Speed Urban Highways ( $e_{max} = 0.10$ ) .....	3-21
Table 3 – 11	Superelevation Rates for Low Speed Arterials and Collectors ( $e_{max} = 0.05$ ) .....	3-22
Table 3 – 12	Minimum Radii (feet) for Design Superelevation Rates Low Speed Local Roads ( $e_{max} = 0.05$ ).....	3-23
Table 3 – 13	Superelevation Transition Slope Rates .....	3-26
Table 3 – 14	Horizontal Curvature .....	3-30
Table 3 – 15A	Calculated and Design Values for Traveled Way Widening on Open Highway Curves (Two-Lane Highways, One-Way or Two-Way) .....	3-32
Table 3 – 15B	Adjustments for Traveled Way Widening Values on Open Highway Curves (Two-Lane Highways, One-Way or Two-Way).....	3-33
Table 3 – 16	Maximum Grades (in Percent) .....	3-35
Table 3 – 17	Maximum Change in Grade Without Using Vertical Curve.....	3-37
Table 3 – 18	Rounded K Values for Minimum Lengths Vertical Curves (Stopping Sight Distance) .....	3-38
Table 3 - 19	Design Controls for Crest Vertical Curves (Passing Sight Distance) ..	3-40
Table 3 – 20	Minimum Lane Widths.....	3-44
Table 3 – 21	Minimum Shoulder Widths for Flush Shoulder Highways.....	3-47
Table 3 – 22	Shoulder Cross Slope .....	3-48
Table 3 – 23	Minimum Median Width.....	3-52

# DRAFT

Table 3 – 24	Minimum Parallel Parking Lane Width ..... <b>Error! Bookmark not defined.</b>	
Table 3 – 25	Parking Restrictions for Driveways, Intersections and Mid-Block Crosswalks .....	3-75
Table 3 – 26	Access Control for All Limited Access Highways .....	3-83
Table 3 – 27	Minimum Stopping Sight Distance (Rounded Values) .....	3-89
Table 3 – 28	Length of Taper for Use in Conditions with Full Width Speed Change Lanes .....	3-100
Table 3 – 29	Design Lengths of Speed Change Lanes Flat Grades - 2 Percent or Less .....	3-103
Table 3 – 30	Ratio of Length of Speed Change Lane on Grade to Length on Level .....	3-104
Table 3 – 31	Minimum Acceleration Lengths for Entrance Terminals .....	3-105
Table 3 – 32	Minimum Deceleration Lengths for Exit Terminals .....	3-107
Table 3 – 33	Turn Lanes – Curbed and Uncurbed Medians .....	3-113
Table 3 – 34	Superelevation Rates for Curves at Intersections.....	3-114
Table 3 – 35	Maximum Rate of Change in Pavement Edge Elevation for Curves at Intersections .....	3-115
Table 3 – 36	Maximum Algebraic Difference in Pavement Cross Slope at Turning Roadway Terminals .....	3-115
Table 3 – 37	Derived Pavement Widths for Turning Roadways for Different Design Vehicles .....	3-117



## FIGURES

Figure 3 – 1A	Horizontal Sight Line Offset Distances for Stopping Sight Distance on Horizontal Curves.....	3-28
Figure 3 – 1B	Diagram Illustrating Components for Determining Horizontal Sight Distance .....	3-29
Figure 3 – 2	Critical Length Versus Upgrade.....	3-36
Figure 3 – 3	Length of Crest Vertical Curve (Stopping Sight Distance).....	3-39
Figure 3 – 4	Length of Sag Vertical Curve (Open Road Conditions) .....	3-41
Figure 3 – 5	General Types and Shapes of Islands and Medians .....	3-54
Figure 3 – 6	Channelization Island for Pedestrian Crossings (Curbed).....	3-58
Figure 3 – 7	Details of Corner Island for Turning Roadways (Curbed).....	3-59
Figure 3 – 8	Details of Corner Island for Turning Roadways (Flush Shoulder) .....	3-60
Figure 3 – 9	Alignment for Divisional Islands at Intersections.....	3-62
Figure 3 – 10	Pedestrian Refuge Island.....	3-63
Figure 3 – 11	Pedestrian Crossing with Refuge Island (Yield Condition) .....	3-64
Figure 3 – 12	Pedestrian Crossing with Refuge Island (Stop Condition).....	3-65
Figure 3 – 13	Pedestrian Crossing in Refuge Island .....	3-67
Figure 3 – 14	Standard Detail for FDOT Type F and E Curbs .....	3-68
Figure 3 – 15	Signing and Marking of Parallel Parking Spaces .....	3-70
Figure 3 – 16	Signing and Marking for 45 degree Forward-In Angle Parking .....	3-71
Figure 3 – 17	Signing and Marking for 45 degree Reverse-In Angle Parking .....	3-73
Figure 3 – 18	Sight Distances for Approach to Stop on Grades .....	3-90
Figure 3 – 19	Departure Sight Triangle (Traffic Approaching from Left or Right) .....	3-93
Figure 3 – 20	Intersection Sight Distance .....	3-94
Figure 3 – 21	Sight Distance for Vehicle Turning Left from Major Road.....	3-99
Figure 3 – 22	Termination of Merging Lanes .....	3-101
Figure 3 – 23	Entrance for Deceleration Lane .....	3-108
Figure 3 – 24	Auxiliary Lanes for Deceleration at Intersections (Turn Lanes).....	3-112

## CHAPTER 3

### GEOMETRIC DESIGN

#### A INTRODUCTION

Geometric design is defined as the design or proportioning of the visible elements of the street or highway. The geometry of the street or highway is of central importance since it provides the framework for the design of other highway elements. In addition, the geometric design establishes the basic nature and quality of the vehicle path, which has a primary effect upon the overall safety characteristics of the street or highway.

The design of roadway geometry must be conducted in close coordination with other design elements of the street or highway. These other elements include pavement design, roadway lighting, traffic control devices, transit, drainage, and structural design. The design should consider safe roadside clear zones, pedestrian safety, emergency response, and maintenance capabilities.

The safety characteristics of the design should be given primary consideration. The initial establishment of sufficient right of way and adequate horizontal and vertical alignment is not only essential from a safety standpoint, but also necessary to allow future upgrading and expansion without exorbitant expenditure of highway funds.

The design elements selected should be reasonably uniform but should not be inflexible.

The minimum standards presented in this chapter should not automatically become the standards for geometric design. The designer should consider use of a higher level, when practical, and consider cost-benefits as well as consistency with adjacent facilities. Reconstruction and maintenance of facilities should, where practical, include upgrading to these minimum standards.

In restricted or unusual conditions, it may not be possible to meet the minimum standards. In such cases, the designer shall obtain an exception in accordance with **Chapter 14 – Design Exceptions and Variations** from the reviewing or permitting organization. However, every effort should be made to obtain the best possible alignment, grade, sight distance, and proper drainage consistent with the terrain, the development, safety, and fund availability. The concept of road users has expanded in recent years creating additional considerations for the designer.

# DRAFT

In making decisions on the standards to be applied to a particular project, the designer must also address the needs of pedestrians, bicyclists, elder road and transit users, people with disabilities, freight movement and other users and uses. This is true for both urban and rural facilities.

The design features of urban local streets are governed by practical limitations to a greater extent than those of similar roads in rural areas. The two dominant design controls are: (1) the type and extent of urban development and its limitations on rights of way and (2) zoning or regulatory restrictions. Some streets primarily are land service streets in residential areas. In such cases, the overriding consideration is to foster a safe and pleasing environment. Other streets are land service only in part, and features of traffic and public transit service may be predominant.

The selection of the type and exact design details of a particular street or highway requires considerable study and thought. When specific criteria are not provided in this Manual and reference is made to guidelines and design details given by current American Association of State Highway and Transportation Officials (AASHTO) publications, these guidelines and standards should generally be considered as minimum criteria. For the design of recreational roads, local service roads, and alleys, see [\*A Policy on Geometric Design of Highways and Streets \(AASHTO, 2011\)\*](#), also known as the [\*AASHTO Greenbook \(2011\)\*](#) and other publications.

Right of way and pavement width requirements for new construction may be reduced for the paving of certain existing unpaved streets and very low volume rural roads provided all ~~of~~ the conditions listed below are satisfied:

- The road is functionally classified as a local road.
- The 20-year projected ADT is less than or equal to 400 vehicles per day and the design year projected peak hourly volume is 100 vehicles per hour or less. Note: The design year may be any time within a range of the present to 20 years in the future, depending on the nature of the improvement.
- The road has no foreseeable probability of changing to a higher functional classification through changes in land use, extensions to serve new developing land areas, or any other use which would generate daily or hourly traffic volumes greater than those listed above.
- There is no reasonable possibility of acquiring additional right of way without.
- Incurring expenditures of public funds in an amount which would be excessive compared to the public benefits achieved.

- Causing substantial damage or disruption to abutting property improvements to a degree that is unacceptable considering the local environment

## B OBJECTIVES

The major objective in geometric design is to establish a vehicle path and environment providing a reasonable margin of safety for the motorist, transit, bicyclist, and pedestrian under the expected operating conditions and speed. It is recognized that Florida's design driver is aging, and tourism is our major industry. This gives even more emphasis on simplicity and easily understood geometry. The design of street or highway features should consider the following:

- Provide the most simple geometry attainable, consistent with the physical constraints
- Provide a design that has a reasonable and consistent margin of safety at the expected operating speed
- Provide a design that is safe at night and under adverse weather conditions
- Provide a facility that is adequate for the expected traffic conditions and transit needs
- Allow for reasonable deficiencies in the driver, such as:
  - Periodic inattention
  - Reduced skill and judgment
  - Slow reaction and response
- Provide an environment that minimizes hazards, is as hazard free as practical, and is "forgiving" to a vehicle that has deviated from the travel path or is out of control.

## C DESIGN ELEMENTS

### C.1 Design Speed

Design speed is a selected speed used to determine the various geometric design features of the street or highway. Selection of an appropriate design speed must consider the anticipated operating speed, topography, existing and future adjacent land use, and functional classification. Consideration must also be given to pedestrian and bicycle usage.

Many critical design features such as sight distance and curvature are directly related to, and vary appreciably with, design speed. For this reason, the selected design speed should be consistent with the speeds that drivers are likely to expect

# DRAFT

on a given street or highway facility. The design speed shall not be less than the expected posted or legal speed limit. Once the design speed is selected, all pertinent highway features should be related to it to obtain a balanced design.

Above minimum design criteria for specific design elements such as flatter curves and longer sight distances should be used where practical, particularly on high speed facilities. On lower speed facilities, use of above minimum values may encourage travel at speeds higher than the design speed.

The design speed utilized should be consistent over a given section of street or highway. Required changes in design speed should be effected in a gradual fashion. When isolated reductions in design speed cannot reasonably be avoided, appropriate speed signs should be posted.

Minimum and maximum values for design speed are given in Table 3 – 1 Minimum and Maximum Design Speed.

High speed facilities are defined as those facilities with design speeds 50 mph and greater. Low speed facilities are defined as those facilities with design speeds 45 mph and less. The posted speed shall be less than or equal to the design speed.

The [AASHTO Greenbook \(2011\)](#) provides additional information on design speed.

# DRAFT

**Table 3 – 1 Minimum and Maximum Design Speed (mph)**

Facility <sup>1</sup>		AADT (vpd)	Terrain	Design Speed (mph)
Freeways	Rural	All	Level and Rolling	70
	Urban	All	Level and Rolling	50 – 70 <sup>2</sup>
Arterials	Rural	All	Level	60 – 70
			Rolling	50 – 70
	Urban	All	All	30 – 60 <sup>3</sup>
Collectors	Rural	≥ 400	Level	60 – 65 (50 mph min for AADT 400 to 2000)
			Rolling	50 – 65 (40 mph min for AADT 400 to 2000)
	< 400	Level	40 – 60	
		Rolling	30 – 60	
	Urban	All	All	30 – 50 <sup>3</sup>
Local	Rural	≥ 400	Level	50 – 60
			Rolling	40 – 60
	< 400	Level	30 – 50	
		Rolling	20 – 40	
	Urban	All	All	20 – 30 <sup>4</sup>

**Footnotes:**

1. Urban design speeds are applicable to streets and highways located within designated urban boundaries as well as those streets and highways outside designated urban boundaries yet within small communities or urban like developed areas. Rural design speeds are applicable to all other rural areas.
2. A design speed of 70 mph should be used for urban freeways when practical. Lower design speeds should only be used in highly developed areas with closely spaced interchanges. For these areas a minimum design speed of 60 mph is recommended unless it can be shown lower speeds will be consistent with driver expectancy.
3. Lower speeds apply to central business districts and in more developed areas while higher speeds are more applicable to outlying and developing areas.
4. Since the function of urban local streets is to provide access to adjacent property, all design elements should be consistent with the character of activity on and adjacent to the street, and should encourage speeds generally not exceeding 30 mph.

## C.2 Design Vehicles

A "design vehicle" is a vehicle with representative weight, dimensions, and operating characteristics, used to establish street and highway design controls for accommodating vehicles of designated classes. For the purpose of geometric design, the design vehicle should be one with dimensions and minimum turning radii larger than those of almost all vehicles in its class. Design vehicles are listed in Table 3 – 2 Design Vehicles. One or more of these vehicles should be used as a control in the selection of geometric design elements. In certain industrial (or other) areas, special service vehicles may have to be considered in the design. Fire equipment and emergency vehicles should have reasonable access to all areas. Additional information on the maximum width, height and length of vehicles in Florida can be found in [Section 316.515, F.S. Motor Vehicles; Maximum width, height, length.](#)

If a significant number or percentage (5 percent of all the total traffic) of vehicles of those classes larger than passenger vehicles are likely to use a particular street or highway, that class should be used as a design control. The design of arterial streets and highways should normally be adequate to accommodate all design vehicles. The decision as to which of the design vehicles (or other special vehicles) should be used as a control is complex and requires careful study. Each situation must be evaluated individually to arrive at a reasonable estimate of the type and volume of expected traffic.

- Design criteria significantly affected by the type of vehicle include:
- Horizontal and vertical clearances
- Alignment
- Lane widening on curves
- Shoulder width requirements
- Turning roadway and intersection radii
- Intersection sight distance
- Acceleration criteria

Particular care should be taken in establishing the radii at intersections, so vehicles may enter the street or highway without encroaching on adjacent travel lanes or leaving the pavement. It is acceptable for occasional trucks or buses to make use of both receiving lanes, especially on side streets.

# DRAFT

**Table 3 – 2 Design Vehicles**

Design Vehicle		Dimensions (feet)					
Type	Symbol	Wheelbase	Overhang		Overall Length	Overall Width	Height
			Front	Rear			
Passenger Car	P	11	3	5	19	7	4.3
Single Unit Truck	SU-30	20	4	6	30	8	11-13.5
Single Unit Truck – 3 Axle	SU-40	25	4	10.5	39.5	8	11-13.5
City Transit Bus	CITY-BUS	25	7	8	40	8.5	10.5
Conventional School Bus (65 passenger)	S-BUS 36	21.3	2.5	12.0	35.8	8.0	10.5
Articulated Bus	A-BUS	22+19.4=41.4	8.6	10	60	8.5	11
Motor Home	MH	20	4	6	30	8	12
Car & Camper Trailer	P/T	11+5+17.7=33.7**	3	12	48.7	8	10
Car & Boat Trailer	P/B	11+5+15=31**	3	8	42	8	---
Intermediate Semitrailer***	WB-40	12.5+25.5=38	3	4.5	45.5	8	13.5
Intermediate Semitrailer	WB-50	14.6+35.4=50	3	2	55	8.5	13.5
Interstate Semitrailer***	WB-62	19.5+41=60.5	4	4.5	69	8.5	13.5
Florida Interstate Semitrailer***	WB-62FL	19.5+41=60.5	4	9	73.5	8.5	13.5
Interstate Semitrailer***	WB-67	21.6+45.4=67	4	2.5	73.5	8.5	13.5
"Double-Bottom"-Semitrailer/Trailer Combination	WB-67D	11+23+10*+22.5=66.5	2.3	3.0	72.3	8.5	13.5

Source: 2011 AASHTO Greenbook, Design Controls and Criteria, Table 2-1b.

- \* Distance between rear wheels of front trailer and front wheels of rear trailer
- \*\* Distance between rear wheels of trailer and front wheels of car
- \*\*\* The term "Interstate" does not imply the vehicle is restricted to interstate and limited access highways only.



# DRAFT

Topic # 625-000-015  
Manual of Uniform Minimum Standards  
for Design, Construction and Maintenance  
for Streets and Highways

---

~~2023~~2018

The minimum turning radii of design vehicles is presented in Table 3 – 3 Minimum Turning Radii of Design Vehicles. The principal dimensions affecting design are the minimum centerline turning radius, the out-to-out track width, the wheelbase, and the path of the inner rear tire. The speed of the turning vehicle is assumed to be less than 10 mph.

The boundaries of the turning path of each design vehicle for its sharpest turns are established by the outer trace of the front overhang and path of the inner rear wheel. This sharpest turn assumes that the outer front wheel follows the circular arc defining the minimum centerline turning radius as determined by the vehicle steering mechanism.

Figures illustrating the minimum turning radii for a variety of vehicles along with additional information can be found in the [AASHTO Greenbook \(2011\), Chapter 2 – Design Controls and Geometrics.](#)

**Table 3 – 3 Minimum Turning Radii of Design Vehicles**

Design Vehicle	Symbol	Dimensions In Feet		
		Minimum Design Turning Radius	Centerline Turning* Radius	Minimum Inside Radius
Passenger Car	P	23.8	21.0	14.4
Single Unit Truck	SU-30	41.8	38.0	28.4
Single Unit Truck – 3 Axle	SU-40	51.2	47.4	36.4
City Transit Bus	CITY-BUS	41.6	37.8	24.5
Conventional School Bus (65 passenger)	S-BUS 36	38.6	34.9	23.8
Articulated Bus	A-BUS	39.4	35.5	21.3
Motor Home	MH	39.7	36.0	26.0
Car & Camper Trailer	P/T	32.9	30.0	18.3
Car & Boat Trailer	P/B	23.8	21.0	8.0
Intermediate Semitrailer	WB-40	39.9	36.0	19.3
Intermediate Semitrailer	WB-50	45	41	17.0
Interstate Semitrailer	WB-62	44.8	41.0	7.4
Florida Interstate Semitrailer***	WB-62FL	44.8	41.0	7.4
"Double-Bottom"-Semitrailer/Trailer Combination	WB-67D	44.8	40.9	19.1

Source: 2011 AASHTO Greenbook, Design Controls and Criteria, Table 2-2b.

\* The turning radius assumed by a designer when investigating possible turning paths and is set at the centerline of the front axle of a vehicle. If the minimum turning path is assumed, the CTR approximately equals the minimum design turning radius minus one-half the front width of the vehicle.

## C.3 Sight Distance

The provision for adequate horizontal and vertical sight distance is an essential factor in the development of a safe street or highway. An unobstructed view of the upcoming roadway is necessary to allow time and space for the safe execution of passing, stopping, intersection movements, and other normal and emergency maneuvers. It is also important to provide as great a sight distance as possible to allow the driver time to plan for future actions. The driver is continuously required to execute normal slowing, turning, and acceleration maneuvers. If he can plan in advance for these actions, traffic flow will be smoother and less hazardous. Unexpected emergency maneuvers will also be less hazardous if they are not combined with uncertainty regarding the required normal maneuvers. The appropriate use of lighting (**Chapter 6 – Lighting**) may be required to provide adequate sight distances for night driving.

Future obstruction to sight distance that may develop (e.g., vegetation) or be constructed should be taken into consideration in the initial design. Areas outside of the road right of way that are not under the highway agency's jurisdiction should be considered as points of obstruction. Planned future construction of median barriers, guardrails, grade separations, or other structures should also be considered as possible sight obstructions.

### C.3.a Stopping Sight Distance

Safe stopping sight distances shall be provided continuously on all streets and highways. The factors, which determine the minimum distance required to stop, include:

- Vehicle speed
- Driver's total reaction time
- Characteristics and conditions of the vehicle
- Friction capabilities between the tires and the roadway surface
- Vertical and horizontal alignment of the roadway

It is desirable that the driver be given sufficient sight distance to avoid an object or slow-moving vehicle with a natural, smooth maneuver rather than an extreme or panic reaction.

The determination of available stopping sight distance shall be based on a height of the driver's eye equal to 3.50 feet and a height of obstruction to be

avoided equal to 2.0 feet. It would, of course, be desirable to use a height of obstruction equal to zero (coincident with the roadway surface) to provide the driver with a more positive sight condition. Where horizontal sight distance may be obstructed on curves, the driver's eye and the obstruction shall be assumed to be located at the centerline of the traffic lane on the inside of the curve.

The stopping sight distance shall be no less than the values given in Table 3 – 4 Minimum Stopping Sight Distance for level and rolling roadways.

**Table 3 – 4 Minimum Stopping Sight Distance**

Design Speed (mph)	Stopping Sight Distance (feet)						
	Level (≤ 2%)	Downgrades			Upgrades		
		3%	6%	9%	3%	6%	9%
		3%	6%	9%	3%	6%	9%
20	115	116	120	126	109	107	104
25	155	158	165	173	147	143	140
30	200	205	215	227	200	184	179
35	250	257	271	287	237	229	222
40	305	315	333	354	289	278	269
45	360	378	400	427	344	331	320
50	425	446	474	507	405	388	375
55	495	520	553	593	469	450	433
60	570	598	638	686	538	515	495
65	645	682	728	785	612	584	561
70	730	771	825	891	690	658	631

Source: 2011 AASHTO Greenbook, Table 3-1 Stopping Sight Distance on Level Roadways and Table 3-2 Stopping Sight Distance on Grades.

### **C.3.b Decision Sight Distance**

Decision sight distance is the distance needed for a driver to detect an unexpected or otherwise difficult to perceive information source or condition in a roadway environment that may be visually cluttered. It allows the driver to recognize the condition or its potential threat, select an appropriate speed and path, and initiate and complete complex maneuvers. Minimum stopping distance does not provide sufficient space or time for the driver to make decisions regarding complex situations requiring more than simple perception-reaction process.

Examples of critical locations where additional sight distance is needed include interchange and intersection locations, where unusual or unexpected maneuvers are needed, changes in typical sections such as toll plazas or lane drops, and areas of concentrated demand where there is visual noise from competing sources of information, such as roadway elements, traffic, traffic control devices and advertising signs.

The decision sight distances in Table 3 – 5 Decision Sight Distance may be used (1) to provide values for sight distances that may be appropriate at critical locations, and (2) to serve as criteria for evaluating the suitability of the available sight distances at these locations. If it is not practical to provide decision sight distance because of horizontal or vertical curvature or if relocation of decision points is not practical, special attention should be given to using appropriate traffic control devices providing advance warning of the conditions that are likely to be encountered.

**Table 3 – 5 Decision Sight Distance**

<b>Design Speed (mph)</b>	<b>Decision Sight Distance (feet)</b>				
	<b>Level Avoidance Maneuver</b>				
	<b>A</b>	<b>B</b>	<b>C</b>	<b>D</b>	<b>E</b>
20	130	305	300	355	410
25	170	395	375	445	515
30	220	490	450	535	620
35	275	590	525	625	720
40	330	690	600	715	825
45	395	800	675	800	930
50	465	910	750	890	1030
55	535	1030	865	980	1135
60	610	1150	990	1125	1280
65	695	1275	1050	1220	1365
70	780	1410	1105	1275	1445

Source: 2011 AASHTO Greenbook, Table 3 - 3 Decision Sight Distance

- Notes:
1. Avoidance Maneuver A: Stop on rural road – t = 3.0 s
  2. Avoidance Maneuver B: Stop on urban road – t = 9.1 s
  3. Avoidance Maneuver C: Speed/path/direction change on rural road – t varies between 10.2 and 11.2 s
  4. Avoidance Maneuver D: Speed/path/direction change on suburban road – t varies between 12.1 and 12.9 s
  5. Avoidance Maneuver E: Speed/path/direction change on urban road – t varies between 14.0 and 14.5 s

The sight distance on a freeway preceding the approach nose of an exit ramp should exceed the minimum by 25 percent or more. A minimum sight distance of 1000 feet, measured from the driver's eye to the road surface is a desirable goal. There should be a clear view of the exit terminal including the exit nose.

### **C.3.c Passing Sight Distance**

The passing maneuver, which requires occupation of the opposing travel lane, is inherently dangerous. The driver is required to make simultaneous estimates of time, distance, relative speeds, and vehicle capabilities. Errors in these estimates result in frequent and serious crashes.

Streets or highways with two or more travel lanes in a given direction are not subject to requirements for safe passing sight distance. Two-lane, two-way highways should be provided with safe passing sight distance for as much of the highway as feasible. The driver demand for passing opportunity is high and serious limitations on the opportunity for passing reduces the capacity and safe characteristics of the highway.

The distance traveled after the driver's final decision to pass (while encroaching into the opposite travel path) is that which is required to pass and return to the original travel lane in front of the overtaken vehicle. In addition to this distance, the safe passing sight distance must include the distance traveled by an opposing vehicle during this time period, as well as a reasonable margin of safety. Due to the many variables in vehicle characteristics and driver behavior, the passing sight distance should be as long as is practicable.

The determination of passing sight distance shall be based on a height of eye equal to 3.50 feet and a height of object passing equal to 3.50 feet. Where passing is permitted, the passing sight distance shall be no less than the values given in Table 3 – 6 Minimum Passing Sight Distances.

**Table 3 – 6 Minimum Passing Sight Distance**

(For application of passing sight distance, use an eye height of 3.50 feet and an object height of 3.50 feet above the road surface)											
Design Speed (mph)	20	25	30	35	40	45	50	55	60	65	70
Minimum Passing Sight Distance (feet)	400	450	500	550	600	700	800	900	1000	1100	1200

Source: 2011 AASHTO Greenbook, Table 3-4 Passing Sight Distance for Design of Two-Lane Highways.

### C.3.d Intersection Sight Distance

Sight distances for intersection movements are given in the general intersection requirements (C.9 Intersection Design, this chapter).

## C.4 Horizontal Alignment

### C.4.a General Criteria

The standard of alignment selected for a particular section of street or highway should extend throughout the section with no sudden changes from easy to sharp curvature. Where sharper curvature is unavoidable, a sequence of curves of increasing degree should be utilized.

Winding alignment consisting of sharp curves is hazardous, reduces capacity, and should be avoided. The use of as flat a curve as possible is recommended. Flatter curves are not only less hazardous, but also frequently less costly due to the shortened roadway.

Maximum curvature should not be used in the following locations:

- High fills or elevated structures. The lack of surrounding objects reduces the driver's perception of the roadway alignment.
- At or near a crest in grade.
- At or near a low point in a sag or grade.
- At the end of long tangents.
- At or near intersections, transit stops, or points of ingress or egress.



- At or near other decision points.

The "broken back" arrangement of curves (short tangent between two curves in the same direction) should be avoided. This is acceptable only at design speeds of 30 mph or less. This arrangement produces unexpected and hazardous situations.

When reversals in alignment are used and superelevation is required, a sufficient length of tangent between the reverse curves is required for adequate superelevation transition.

Compound curves should be avoided, especially when curves are sharp. They tend to produce erratic and dangerous vehicle operations. When compound curves are necessary, the radius of the flatter curve should not be more than 50 percent greater than the sharper curve.

The transition between tangents and curves should normally be accomplished by the use of appropriate straight-line transitions or spirals. This is essential to assist the driver in maintaining his vehicle in the proper travel path.

#### **C.4.b Maximum Deflections in Alignment without Curves**

The point where tangents intersect is known as the point of intersection (PI). Although the use of a PI with no horizontal curve is discouraged, there may be conditions where it is necessary. The maximum deflection criteria without a horizontal curve are as follows:

- Flush shoulder and curbed roadways with design speed 40 mph and less is  $2^{\circ} 00' 00''$ .
- Flush shoulder roadways with design speed 45 mph and greater is  $0^{\circ} 45' 00''$ .
- Curbed roadways with design speed 45 mph and greater is  $1^{\circ} 00' 00''$ .
- High speed curbed roadways with design speed 50 mph and greater is  $0^{\circ} 45' 00''$ .

Although deflections through intersections are discouraged, there may be conditions where it is necessary. The maximum deflection angles at

intersections to be used in establishing the horizontal alignment are given in Table 3 – 7 Maximum Deflection Angle Through Intersection.

**Table 3 – 7 Maximum Deflection Angle Through Intersection**

Design Speed (mph)					
≤ 20	25	30	35	40	45
16° 00'	11° 00'	8° 00'	6° 00'	5° 00'	3° 00'

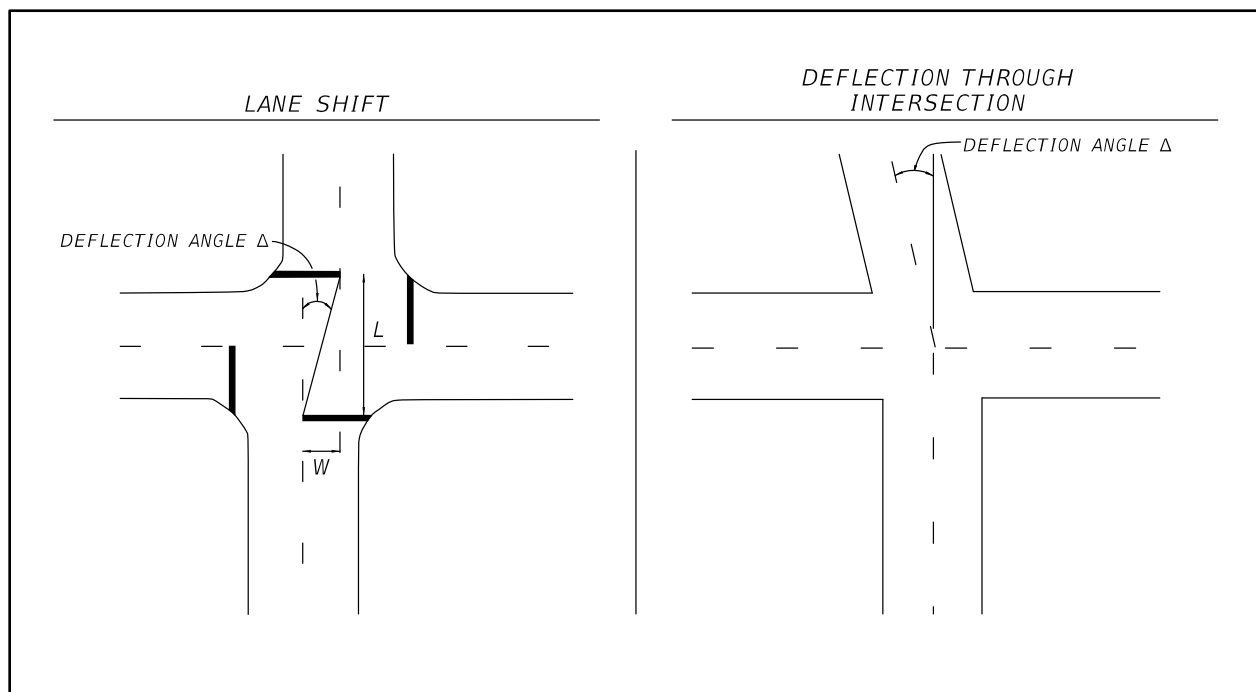

Notes 1. The deflection angle used is not to cause a lane shift (W) of more than 6 feet from stop bar to stop bar.

Curves on main roadways should be sufficiently long to avoid the appearance of a kink. Gently flowing alignment is generally more pleasing in appearance, as well as, superior from a safety standpoint. Flatter curvature with shorter tangents is preferable to sharp curves connected by long tangents, i.e., avoid using minimum horizontal curve lengths. Table 3-8 Minimum Lengths of Horizontal Curves provides minimum horizontal curve lengths that should be used in establishing the horizontal alignment.

**Table 3 – 8 Minimum Lengths of Horizontal Curves**

<b>Curve Length Based on Design Speed</b>										
Design Speed (mph)	25	30	35	40	45	50	55	60	65	70
Arterials, Collectors (Length in feet = 15 x Design Speed, but not less than 400 feet)	400	450	525	600	675	750	825	900	975	1050
Freeways - Mainline (Length in feet = 30 x Design Speed)	--	--	--	--	--	1500	1650	1800	1950	2100
<b>Curve Length Based on Deflection Angle</b>										
Deflection Angle (degrees)	5°		4°		3°		2°		1°	
Curve Length (feet)	500		600		700		800		900	
<p>Notes:</p> <ol style="list-style-type: none"> <li>1. Horizontal curve length should be the greater of the lengths based on design speed and length based on deflection angle.</li> <li>2. If the curve lengths for arterials and collectors cannot be attained, provide the greatest attainable length possible, but not less than 400 feet.</li> <li>3. If the curve lengths for mainline freeways cannot be attained, provide the greatest attainable length possible, but not less than the lengths used for arterials and collectors.</li> <li>4. Curve length shall provide for full superelevation within the curve of not less than 200 ft. (Rural) or 100 ft. (Urban).</li> </ol>										

Compound curves are sometimes used for turning roadways at intersections. For turning roadways and intersections a ratio of 2:1 (where the flatter radius precedes the sharper radius in the direction of travel) is acceptable. The arc lengths of compound curves for turning roadways when followed by a curve of one half radius or preceded by a curve of double radius should be as shown in Table 3 – 9 Length of Compound Curves on Turning Roadways.

**Table 3 – 9 Length of Compound Curves on Turning Roadways**

Radius (feet)	100	150	200	250	300	400	≥ 500
Desirable Arc Length (feet)	65	70	100	120	150	180	200
Minimum Arc Length (feet)	40	50	65	85	100	120	150

### C.4.c Superelevation

In the design of street and highway curves, it is necessary to establish a proper relationship between curvature of the roadway and design speed. The use of superelevation (rotation of the roadway about its axis) is employed to counteract centrifugal force and allow drivers to comfortably and safely travel through curves at the design speed.

The terms Rural and Urban used in this section reflect the location of the project. In addition to the criteria provided below, additional information regarding superelevation given in the [Department's FDOT Design Manual](#), and [A Policy on Geometric Design of Highways and Streets \(AASHTO, 2011\)](#), may be considered.

#### C.4.c.1 Rural Highways, Urban Freeways and High Speed Urban Highways

The superelevation rates for high speed (50 mph or greater) roadways are provided in Table 3 – 10 Superelevation Rates for Rural Highways, Urban Freeways and High-Speed Urban Highways (e max =0.10). These rates are based on Method 5 from the [2011 AASHTO Greenbook](#) using a maximum rate of 0.10 foot per foot of

roadway width. Table 3 – 10 also provides the minimum radius required for normal crown without superelevation.

### C.4.c.2 Low Speed Urban Roadways

For low speed (45 mph and less) roadways in urban areas, various factors combine to make superelevation difficult, if not impractical, in many built-up areas. Such factors include:

- Wide pavement areas
- Need to meet grade of adjacent property
- Surface drainage considerations
- Frequency of cross streets, alleys, and driveways

Superelevation rates for low speed urban roadways therefore rely more heavily on side friction than rates used for high speed roadways and the maximum superelevation rate is set at 0.05 foot per foot. Separate criteria are provided for low speed Local Roads vs. low speed Arterials and Collectors as follows:

**Low Speed Urban Arterials and Collectors:** Superelevation rates for low speed urban arterials and collectors are provided in Table 3 – 11 Superelevation Rates for Low Speed Arterials and Collectors ( $e_{max} = 0.05$ ). These rates are based on the [FDOT's the Department's](#) superelevation criteria for low speed arterials and collectors. Table 3 – 11 also provides the minimum radius required for normal crown without superelevation.

**Low Speed Local Roads:** Minimum radii for design superelevation rates for low speed local roads are provided in Table 3 – 12 Minimum Radii (feet) for Design Superelevation Rates, Low Speed Local Roads ( $e_{max} = 0.05$ ). These rates are based on Method 2 from the 2011 AASHTO Greenbook. Table 3 – 12 also provides the minimum radius required for normal crown (-0.02 ft/ft) without superelevation.

# DRAFT

Topic # 625-000-015  
 Manual of Uniform Minimum Standards  
 for Design, Construction and Maintenance  
 for Streets and Highways

20232018

**Table 3 – 10 Superelevation Rates for Rural Highways, Urban Freeways and High Speed Urban Highways (e max = 0.10)**

Tabulated Values										
Degree of Curve <i>D</i>	Radius <i>R</i> (ft.)	Design Speed (mph)								
		30	35	40	45	50	55	60	65	70
0° 15'	22,918	NC	NC	NC	NC	NC	NC	NC	NC	NC
0° 30'	11,459	NC	NC	NC	NC	NC	NC	RC	RC	RC
0° 45'	7,639	NC	NC	NC	NC	RC	RC	0.023	0.025	0.028
1° 00'	5,730	NC	NC	NC	RC	0.021	0.025	0.030	0.033	0.037
1° 15'	4,584	NC	NC	RC	0.022	0.026	0.031	0.036	0.041	0.046
1° 30'	3,820	NC	RC	0.021	0.026	0.031	0.037	0.043	0.048	0.054
	* <i>R</i> <sub>NC</sub>									
2° 00'	2,865	RC	0.022	0.028	0.034	0.040	0.048	0.055	0.062	0.070
	* <i>R</i> <sub>RC</sub>									
2° 30'	2,292	0.021	0.028	0.034	0.041	0.049	0.058	0.067	0.075	0.085
3° 00'	1,910	0.025	0.032	0.040	0.049	0.057	0.067	0.077	0.087	0.096
3° 30'	1,637	0.029	0.037	0.046	0.055	0.065	0.075	0.086	0.095	0.100
4° 00'	1,432	0.033	0.042	0.051	0.061	0.072	0.083	0.093	0.099	Dmax = 3° 30'
5° 00'	1,146	0.040	0.050	0.061	0.072	0.083	0.094	0.098	Dmax = 4° 15'	
6° 00'	955	0.046	0.058	0.070	0.082	0.092	0.099	Dmax = 5° 15'		
7° 00'	819	0.053	0.065	0.078	0.089	0.098	Dmax = 6° 30'			
8° 00'	716	0.058	0.071	0.084	0.095	0.100	Dmax = 8° 15'			
9° 00'	637	0.063	0.077	0.089	0.098	Dmax = 10° 15'				
10° 00'	573	0.068	0.082	0.094	0.100	Dmax = 13° 15'				
11° 00'	521	0.072	0.086	0.097	Dmax = 17° 45'					
12° 00'	477	0.076	0.090	0.099	Dmax = 24° 45'					
13° 00'	441	0.080	0.093	0.100						
14° 00'	409	0.083	0.096							
15° 00'	382	0.086	0.098							
16° 00'	358	0.089	0.099							
18° 00'	318	0.093								
20° 00'	286	0.097								
22° 00'	260	0.099								
24° 00'	239	0.100								
		Dmax = 24° 45'								
* NC/RC and RC/e Break Points (Radius in feet)										
Break Points	Design Speed (mph)									
	30	35	40	45	50	55	60	65	70	
<i>R</i> <sub>NC</sub>	3349	4384	5560	6878	8337	9949	11709	13164	14714	
<i>R</i> <sub>RC</sub>	2471	3238	4110	5087	6171	7372	8686	9783	10955	
e = NC if $R \geq R_{NC}$ e = RC if $R < R_{NC}$ and $R \geq R_{RC}$										

NC = Normal Crown ( -0.02 )      RC = Reverse Crown ( +0.02 )

*R*<sub>NC</sub> = Minimum Radius for NC      *R*<sub>RC</sub> = Minimum Radius for RC

Rates for intermediate D and R's are to be interpolated.

# DRAFT

Topic # 625-000-015  
 Manual of Uniform Minimum Standards  
 for Design, Construction and Maintenance  
 for Streets and Highways

2023~~2018~~

**Table 3 – 11 Superelevation Rates for Low Speed Arterials and Collectors  
 (e<sub>max</sub> = 0.05)**

Tabulated Values					
Degree of Curve <i>D</i>	Radius <i>R</i> (ft.)	Design Speed (mph)			
		30	35	40	45
2° 00'	2,865	NC	NC	NC	NC
2° 15'	2,546				
2° 45'	2,083				NC
3° 00'	1,910				RC
3° 45'	1,528			NC	
4° 00'	1,432			RC	
4° 45'	1,206				
5° 00'	1,146		NC		
5° 15'	1,091		RC		
5° 30'	1,042				
5° 45'	996				
6° 00'	955				RC
6° 15'	917				0.022
6° 30'	881				0.024
6° 45'	849				0.027
7° 00'	819	NC			0.030
7° 15'	790	RC			0.033
7° 30'	764				0.037
7° 45'	739				0.041
8° 00'	716			RC	0.045
8° 15'	694			0.022	0.050
8° 30'	674			0.025	Dmax = 8° 15'
8° 45'	655			0.027	
9° 00'	637			0.030	
9° 30'	603			0.034	
10° 00'	573			0.040	
10° 30'	546		RC	0.047	
11° 00'	521		0.023	Dmax = 10° 45'	
11° 30'	498		0.026		
12° 00'	477		0.030		
13° 00'	441		0.036		
14° 00'	409	RC	0.045		
15° 00'	382	0.023	Dmax = 14° 15'		
16° 00'	358	0.027			
17° 00'	337	0.032			
18° 00'	318	0.038			
19° 00'	302	0.043			
20° 00'	286	0.050			
		Dmax = 20° 00'			

NC = Normal Crown ( -0.02 )      RC = Reverse Crown ( +0.02 )  
 Rates for intermediate D and R's are to be interpolated.

**Table 3 – 12 Minimum Radii (feet) for Design Superelevation Rates  
 Low Speed Local Roads ( $e_{max} = 0.05$ )**

<b>e - ft/ft</b>	<b>Design Speed (mph)</b>							
	<b>10</b>	<b>15</b>	<b>20</b>	<b>25</b>	<b>30</b>	<b>35</b>	<b>40</b>	<b>45</b>
0.05	16	41	83	149	240	355	508	675
0.045	16	41	85	152	245	363	520	692
0.04	16	42	86	154	250	371	533	711
0.035	16	42	87	157	255	380	547	730
0.03	16	43	89	160	261	389	561	750
0.025	16	43	90	163	267	398	577	771
0.02	17	44	92	167	273	408	593	794
0.015	17	45	94	170	279	419	610	818
0.01	17	45	95	174	286	430	627	844
0.005	17	46	97	177	293	441	646	871
0	18	47	99	181	300	454	667	900
-0.01	18	48	103	189	316	480	711	964
-0.02	19	50	107	198	333	510	762	1038
-0.03 <sup>1</sup>	19	52	111	208	353	544	821	1125
-0.04 <sup>1</sup>	20	54	116	219	375	583	889	1227
-0.05 <sup>1</sup>	20	56	121	231	400	628	970	1350

1. Negative superelevation values beyond -0.02 feet per foot should be used only for unpaved surfaces such as gravel, crushed stone, and earth.



#### **C.4.d Maximum Curvature/Minimum Radius**

Where a directional change in alignment is required, every effort should be made to utilize the smallest degree (largest radius) curvature possible. The use of the maximum degree of curvature should be avoided when possible. Design speed maximum degree of curvature or minimum radius for the maximum superelevation rates are provided in Tables 3 – 10 Superelevation Rates for Rural Highways, Urban Freeways and High-Speed Urban Highways, 3 – 11 Superelevation Rates for Low Speed Arterials and Collectors, and 3 – 12 Minimum Radii (feet) for Design Superelevation Rates Low Speed Local Roads. The use of sharper curvature would call for superelevation beyond the limit considered practical or for operation with tire friction beyond safe or comfortable limits or both. The maximum degree of curvature or minimum radius is a significant value in alignment design.

#### **C.4.e Superelevation Transition (superelevation runoffs plus tangent runoff)**

Superelevation runoff is the general term denoting the length of street or highway needed to transition the change in cross slope from a section with the adverse crown removed (level) to the fully superelevated section, or vice versa. Tangent runoff is the general term denoting the length of street or highway needed to accomplish the change in cross slope from a normal cross section to a section with the adverse crown removed, or vice versa.

The standard superelevation transition places 80% of the transition on the tangent and 20% on the curve. In transition sections where the travel lane(s) cross slope is less than 1.5 %, one of the following grade criteria should be applied:

- Maintain a minimum profile grade of 0.5%, or
- Maintain a minimum edge of pavement grade of 0.2% (0.5% for curbed roadways).

When superelevation is required for curves in opposite directions on a common tangent (reverse curves), a suitable distance is required between the curves. This suitable tangent length should be determined as follows:

- 80% of the transition for each curve should be located on the tangent.

# DRAFT

- The suitable tangent length is the sum of the two 80% distances, or greater.
- Where alignment constraints dictate a less than desirable tangent length between curves, an adjustment of the 80/20 superelevation transition treatment is allowed (where up to 50% of the transition may be placed on the curve).

Superelevation transition slope rates used to compute transition lengths are provided in Table 3 –13 Superelevation Transition Slope Rates. The 2011 AASHTO Greenbook provides additional information on superelevation transition design.

~~The~~The ~~FDOT~~Department's ~~–~~[\*\*Standard Plans for Road and Bridge Construction\*\*](#) provide additional information on superelevation transitions for various sections and methods for determining length of transition.

**Table 3 – 13 Superelevation Transition Slope Rates**

Number of Lanes in One Direction	High Speed Roadways				Low Speed Roadways		
	Design Speed (mph)				Design Speed (mph)		
	25-40	45-50	55-60	65-70	25-35	40	45
1-Lane & 2-Lane	1:175	1:200	1:225	1:250	1:100	1:125	1:150
3-Lane	---	1:160	1:180	1:200			
4-Lane or more	---	1:150	1:170	1:190			

**High Speed Roadways:**

1. The length of superelevation transition is to be determined by the relative slope rate between the travel way edge of pavement and the profile grade, except that the minimum length of transition is 100 feet.
2. For additional information on transitions, see the [Standard Plans, Index 000-510](#).

**Low Speed Roadways:**

1. The length of superelevation transition is to be determined by the relative slope rate between the travel way edge of pavement and the profile grade, except that the minimum length of transition is 50 feet for design speeds 25-35 mph and 75 ft. for design speeds 40-45.
2. A slope rate of 1:125 may be used for 45 mph under restricted conditions.
3. For additional information on transitions, see the [Standard Plans, Index 000-511](#).

Spiral curves may be used to transition from the tangent to the curve. Where the spiral curve is employed, its length is used to make the entire superelevation transition. For additional information on the use of spiral curves, see the [2011 AASHTO Greenbook](#).

#### **C.4.f Sight Distance on Horizontal Curves**

Where there are sight obstructions (such as walls, cut slopes, buildings, and longitudinal barriers) on the inside of curves or the inside of the median lane

# DRAFT

on divided highways and their removal to increase sight distance is impractical, a design may need adjustment in the normal highway cross section or alignment. With sight distance for the design speed as a control, make the appropriate adjustments to provide adequate stopping sight distance. Figure 3 – 1A Horizontal Sight Line Offset Distances for Stopping Sight Distance on Horizontal Curves and Figure 3 – 1B Diagram Illustrating Components for Determining Horizontal Sight Distance show the horizontal sight line offsets needed for clear sight areas that satisfy stopping sight distance criteria presented in Table 3 – 3 Minimum Stopping Sight Distances for horizontal curves of radii on flat grades.

**Figure 3 – 1A Horizontal Sight Line Offset Distances for Stopping Sight Distance on Horizontal Curves**

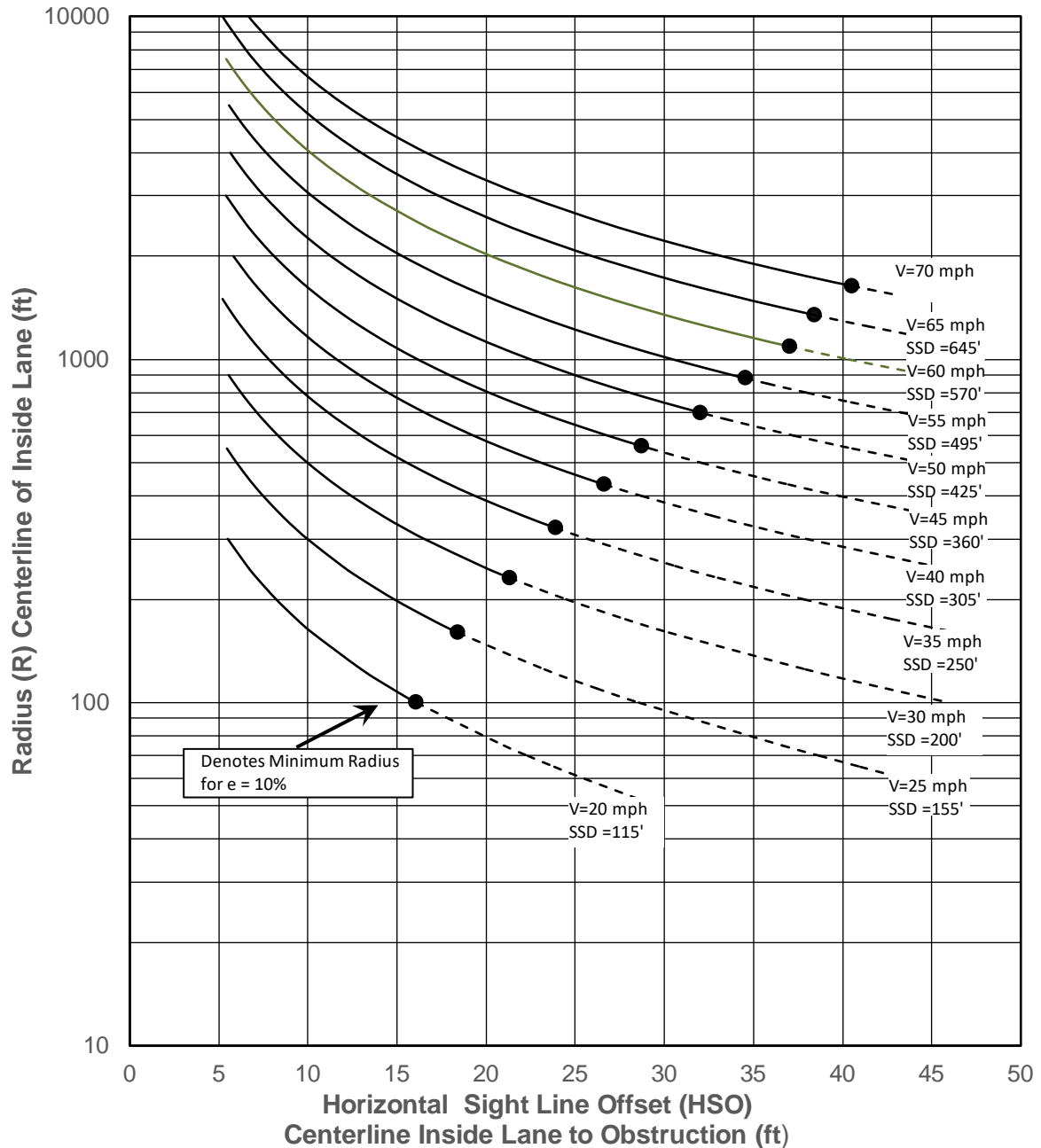

**Figure 3 – 1B Diagram Illustrating Components for Determining Horizontal Sight Distance**

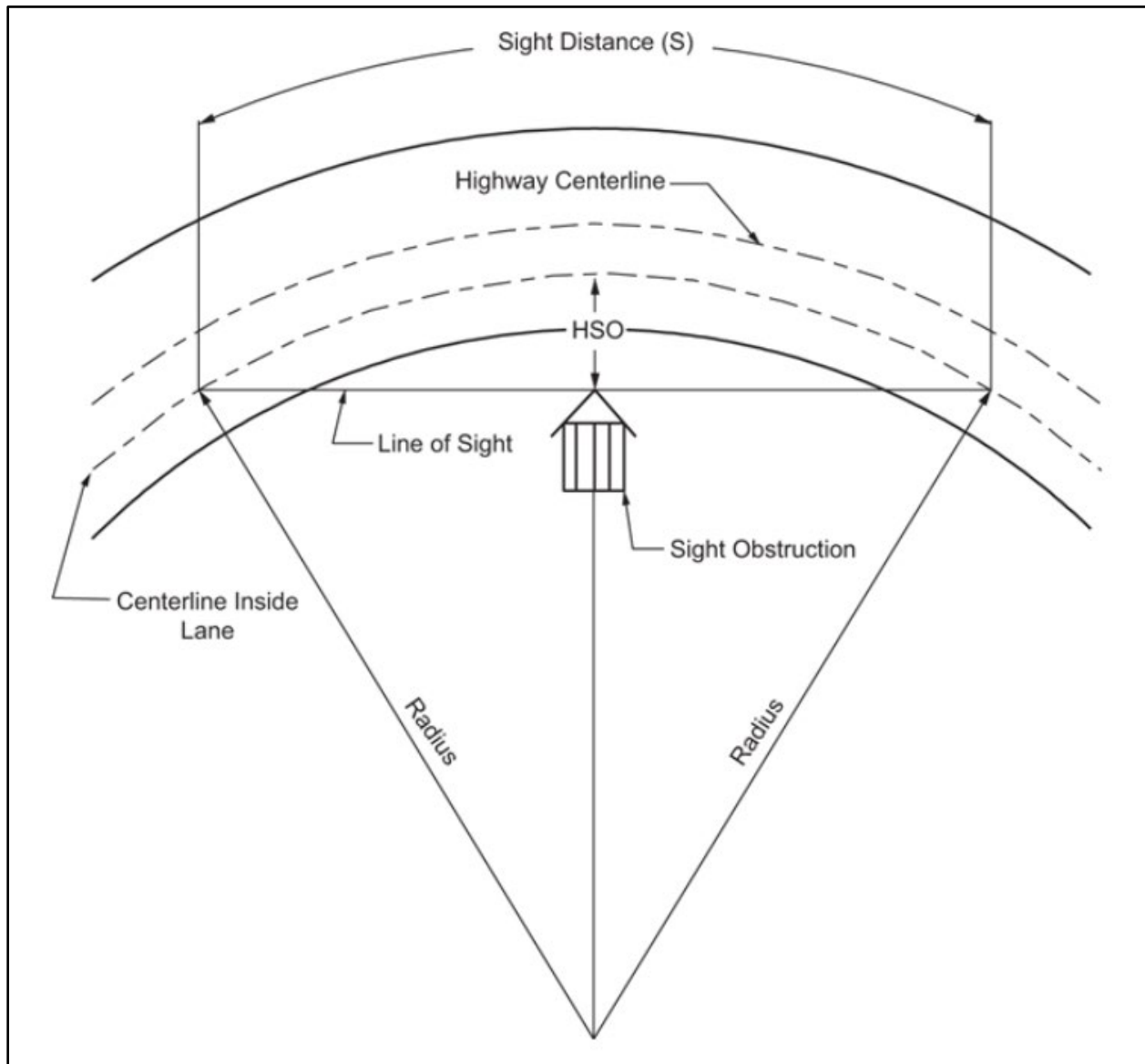

HSO – Horizontal Sight Distance

Source: 2011 AASHTO Greenbook, Figure 3 – 23. Diagram Illustrating Components for Determining Horizontal Sight Distance

# DRAFT

**Table 3 – 14 Horizontal Curvature**

<b>Lateral Clearance from Edge of Traveled Way to Obstruction For Maximum Curvature (Degrees), Based on Line of Sight On Inside Lane (Lateral Clearance = <math>M_{\text{Inside Lane}} - 6'</math>) Based on <math>e_{\text{MAX}} = 0.10</math></b>		
<b>Design Speed (mph)</b>	<b>Maximum Curvature</b>	<b>Clearance (feet)</b>
20	57° 45'	11
25	36° 15'	13
30	24° 45'	16
35	17° 45'	19
40	13° 30'	21
45	10° 15'	23
50	8° 15'	27
55	6° 30'	29
60	5° 15'	31
65	4° 15'	33
70	3° 30'	35

## **C.4.g Lane Widening on Curves**

The traveled way should be widened on sharp curves due to the increased difficulty for the driver to follow the proper path. Trucks and transit vehicles experience additional difficulty due to the fact that the rear wheels may track considerably inside the front wheels thus requiring additional width. Adjustments to traveled way widths for mainline and turning roadways are given in Tables 3 – 15A Calculated and Design Values for Traveled Way Widening on Open Highway Curves (Two-Lane Highways, One-Way or Two-Way and 3 – 15B Adjustments or Traveled Way Widening Values on Open Highway Curves (Two-Lane Highways, One-Way or Two-Way. A transition length shall be introduced in changing to an increased/decreased lane width. This transition length shall be proportional to the increase/decrease in traveled way width in a ratio of not less than 50 feet of transition length for each foot of change in lane width.



<b>Table 3 – 15A Calculated and Design Values for Traveled Way Widening on Open Highway Curves (Two-Lane Highways, One-Way or Two-Way)</b>																					
Radius of Curve (feet)	Roadway width = 24 feet.					Roadway width = 22 feet.					Roadway width = 20 feet.										
	Design Speed (mph)					Design Speed (mph)					Design Speed (mph)										
	30	35	40	45	50	55	60	30	35	40	45	50	55	60	30	35	40	45	50	55	60
7000	0.0	0.0	0.0	0.0	0.0	0.0	0.7	0.7	0.8	0.8	0.9	1.0	1.0	1.0	1.7	1.7	1.8	1.8	1.9	2.0	2.0
6500	0.0	0.0	0.0	0.0	0.0	0.1	0.7	0.8	0.8	0.9	1.0	1.0	1.1	1.1	1.7	1.8	1.8	1.9	2.0	2.0	2.1
6000	0.0	0.0	0.0	0.0	0.1	0.1	0.7	0.8	0.9	0.9	1.0	1.1	1.1	1.1	1.7	1.8	1.9	1.9	2.0	2.0	2.1
5500	0.0	0.0	0.0	0.1	0.1	0.2	0.8	0.9	0.9	1.0	1.1	1.1	1.2	1.2	1.8	1.9	1.9	2.0	2.1	2.1	2.2
5000	0.0	0.0	0.1	0.1	0.2	0.3	0.9	0.9	1.0	1.1	1.1	1.2	1.3	1.3	1.9	1.9	2.0	2.1	2.1	2.2	2.3
4500	0.0	0.0	0.1	0.1	0.2	0.3	0.9	1.0	1.1	1.1	1.2	1.3	1.4	1.4	1.9	2.0	2.1	2.1	2.2	2.3	2.4
4000	0.0	0.1	0.2	0.2	0.3	0.4	1.0	1.1	1.2	1.2	1.3	1.4	1.5	1.5	2.0	2.1	2.2	2.2	2.3	2.4	2.5
3500	0.1	0.2	0.3	0.4	0.5	0.6	1.1	1.2	1.3	1.4	1.5	1.5	1.6	1.6	2.1	2.2	2.3	2.4	2.5	2.5	2.6
3000	0.3	0.4	0.4	0.5	0.6	0.7	1.3	1.4	1.4	1.5	1.6	1.7	1.8	1.8	2.3	2.4	2.4	2.5	2.6	2.7	2.8
2500	0.5	0.6	0.7	0.8	0.9	1.0	1.5	1.6	1.7	1.8	1.9	2.0	2.1	2.1	2.5	2.6	2.7	2.8	2.9	3.0	3.1
2000	0.7	0.9	1.0	1.1	1.2	1.3	1.7	1.9	2.0	2.1	2.2	2.3	2.4	2.4	2.7	2.9	3.0	3.1	3.2	3.3	3.4
1800	0.9	1.0	1.1	1.3	1.4	1.5	1.9	2.0	2.1	2.3	2.4	2.5	2.6	2.6	2.9	3.0	3.1	3.3	3.4	3.5	3.6
1600	1.1	1.2	1.3	1.5	1.6	1.7	2.1	2.2	2.3	2.5	2.6	2.7	2.8	2.8	3.1	3.2	3.3	3.5	3.6	3.7	3.8
1400	1.3	1.5	1.6	1.7	1.9	2.0	2.3	2.5	2.6	2.7	2.9	3.0	3.1	3.1	3.3	3.5	3.6	3.7	3.9	4.0	4.1
1200	1.7	1.8	1.9	2.1	2.2	2.4	2.7	2.8	2.9	3.1	3.2	3.4	3.5	3.5	3.7	3.8	3.9	4.1	4.2	4.4	4.5
1000	2.1	2.3	2.4	2.6	2.7	2.9	3.1	3.3	3.4	3.6	3.7	3.9	4.0	4.0	4.1	4.3	4.4	4.6	4.7	4.9	5.0
900	2.4	2.6	2.7	2.9	3.1	3.2	3.4	3.6	3.7	3.9	4.1	4.2			4.4	4.6	4.7	4.9	5.1	5.2	
800	2.7	2.9	3.1	3.3	3.5	3.6	3.7	3.9	4.1	4.3	4.5	4.6			4.7	4.9	5.1	5.3	5.5	5.6	
700	3.2	3.4	3.6	3.8	4.0		4.2	4.4	4.6	4.8	5.0				5.2	5.4	5.6	5.8	6.0		
600	3.8	4.0	4.2	4.4	4.6		4.8	5.0	5.2	5.4	5.6				5.8	6.0	6.2	6.4	6.6		
500	4.6	4.9	5.1	5.3			5.6	5.9	6.1	6.3					6.6	6.9	7.1	7.3			
450	5.2	5.4	5.7				6.2	6.4	6.7						7.2	7.4	7.7				
400	5.9	6.1	6.4				6.9	7.1	7.4						7.9	8.1	8.4				
350	6.8	7.0	7.3				7.8	8.0	8.3						8.8	9.0	9.3				
300	7.9	8.2					8.9	9.2							9.9	10.2					
250	9.6						10.6								11.6						
200	12.0						13.0								14.0						

Source: 2011 AASHTO Greenbook, Table 3 – 26b Calculated and Design values for Traveled Way Widening on Open Highway Curves.  
 Notes: 1. Values shown are for WB-62 design vehicle and represent widening in feet. For other design vehicles, use adjustments in Table 3-15B.  
 2. Values less than 2.0 feet may be disregarded. For 3-lane roadways, multiply above values by 1.5.

**Table 3 – 15B Adjustments for Traveled Way Widening Values on Open Highway Curves  
 (Two-Lane Highways, One-Way or Two-Way)**

Radius of Curve (FEET)	Design Vehicle						
	SU-30	WB-40				WB-67	WB-67D
7000	-1.2	-1.2				0.1	-0.1
6500	-1.3	-1.2				0.1	-0.1
6000	-1.3	-1.2				0.1	-0.2
5500	-1.3	-1.2				0.1	-0.2
5000	-1.3	-1.3				0.1	-0.2
4500	-1.4	-1.3				0.1	-0.2
4000	-1.4	-1.3				0.1	-0.2
3500	-1.5	-1.4				0.1	-0.3
3000	-1.6	-1.4				0.1	-0.3
2500	-1.7	-1.5				0.2	-0.4
2000	-1.8	-1.6				0.2	-0.5
1800	-1.9	-1.7				0.2	-0.5
1600	-2.0	-1.8				0.2	-0.6
1400	-2.2	-1.9				0.3	-0.6
1200	-2.4	-2.1				0.3	-0.8
1000	-2.7	-2.3				0.4	-0.9
900	-2.8	-2.4				0.4	-1.0
800	-3.1	-2.6				0.5	-1.1
700	-3.4	-2.9				0.6	-1.3
600	-3.8	-3.2				0.7	-1.5
500	-4.3	-3.6				0.8	-1.8
450	-4.7	-3.9				0.9	-2.0
400	-5.2	-4.3				1.0	-2.3
350	-5.8	-4.7				1.1	-2.6
300	-6.6	-5.4				1.3	-3.0
250	-7.7	-6.3				1.6	-3.6
200	-9.4	-7.6				2.0	-4.6

Source: 2011 AASHTO Greenbook, Table 3 - 27 Adjustments for Traveled Way Widening Values on Open Highway Curves.

- Notes:
1. Adjustments are applied by adding to or subtracting from the values in Table 3-15A.
  2. Adjustments depend only on radius and design vehicle; they are independent of traveled way width and design speed.
  3. For 3-lane roadways, multiply above values by 1.5.
  4. For 4-lane roadways, multiply above values by 2.0.

## C.5 Vertical Alignment

### C.5.a General Criteria

The selection of vertical alignment should be predicated to a large extent upon the following criteria:

- Obtaining maximum sight distances
- Limiting speed differences (particularly for trucks and buses) by reducing magnitude and length of grades
- A "hidden dip" which would not be apparent to the driver must be avoided.
- Steep grades and sharp crest vertical curves should be avoided at or near intersections.
- Flat grades and long gentle vertical curves should be used whenever possible.

### C.5.b Grades

The grades selected for vertical alignment should be as flat as practical, and should not be greater than the value given in Table 3 – 16 Maximum Grades in Percent.

For streets and highways requiring long upgrades, the maximum grade should be reduced so the speed reduction of slow-moving vehicles (e.g., trucks and buses) is not greater than 10 mph. The critical lengths of grade for these speed reductions are shown in Figure 3 – 2 Critical Length Versus Upgrade. Where reduction of grade is not practical, climbing lanes should be provided to meet these speed reduction limitations.

The criteria for a climbing lane and the adjacent shoulder are the same as for any travel lane except that the climbing lane should be clearly designated by the appropriate pavement markings. Entrance to and exit from the climbing lane shall follow the same criteria as other merging traffic lanes; however, the climbing lane should not be terminated until well beyond the crest of the vertical curve. Differences in superelevation should not be sufficient to produce a change in pavement cross slope between the climbing lane and through lane in excess of 0.04 feet per foot.

# DRAFT

Recommended minimum gutter grades:

Rolling terrain - 0.5%    Flat terrain - 0.3%

**Table 3 – 16 Maximum Grades (in Percent)**

Type of Roadway	Level Terrain											Rolling Terrain											
	Design Speed (mph)											Design Speed (mph)											
	20	25	30	35	40	45	50	55	60	65	70	20	25	30	35	40	45	50	55	60	65	70	
Freeway <sup>1</sup>	---	---	---	---	---	---	4	4	3	3	3	---	---	---	---	---	---	5	5	4	4	4	
Arterial	Rural	---	---	---	---	5	5	4	4	3	3	3	---	---	---	---	6	6	5	5	4	4	4
	Urban	---	---	8	7	7	6	6	5	5	---	---	---	---	9	8	8	7	7	6	6	---	---
Collector <sup>2</sup>	Rural	7	7	7	7	7	7	6	6	5	---	---	10	10	9	9	8	8	7	7	6	---	---
	Urban	9	9	9	9	9	8	7	7	6	---	---	12	12	11	10	10	9	8	8	7	---	---
Local <sup>3</sup>	Rural	8	7	7	7	7	7	6	6	5	---	---	11	11	10	10	10	9	8	7	6	---	---

Source: 2011 AASHTO Greenbook, Tables 5–2, 6–2, 6–8, 7–2, 7–4, 8–1.

Notes: 1. Grades 1% steeper than the value shown may be provided in urban areas with right of way constraints.

2. Short lengths of grade ( $\leq 500$  feet in length), one-way downgrades, and grades on low volume collectors may be up to 2% steeper than the grades shown above.

3. Residential street grade should be as level as practical, consistent with surrounding terrain, and less than 15%. Streets in commercial or industrial areas should have grades less than 8%, and flatter grades should be encouraged.

**Figure 3 – 2 Critical Length Versus Upgrade**

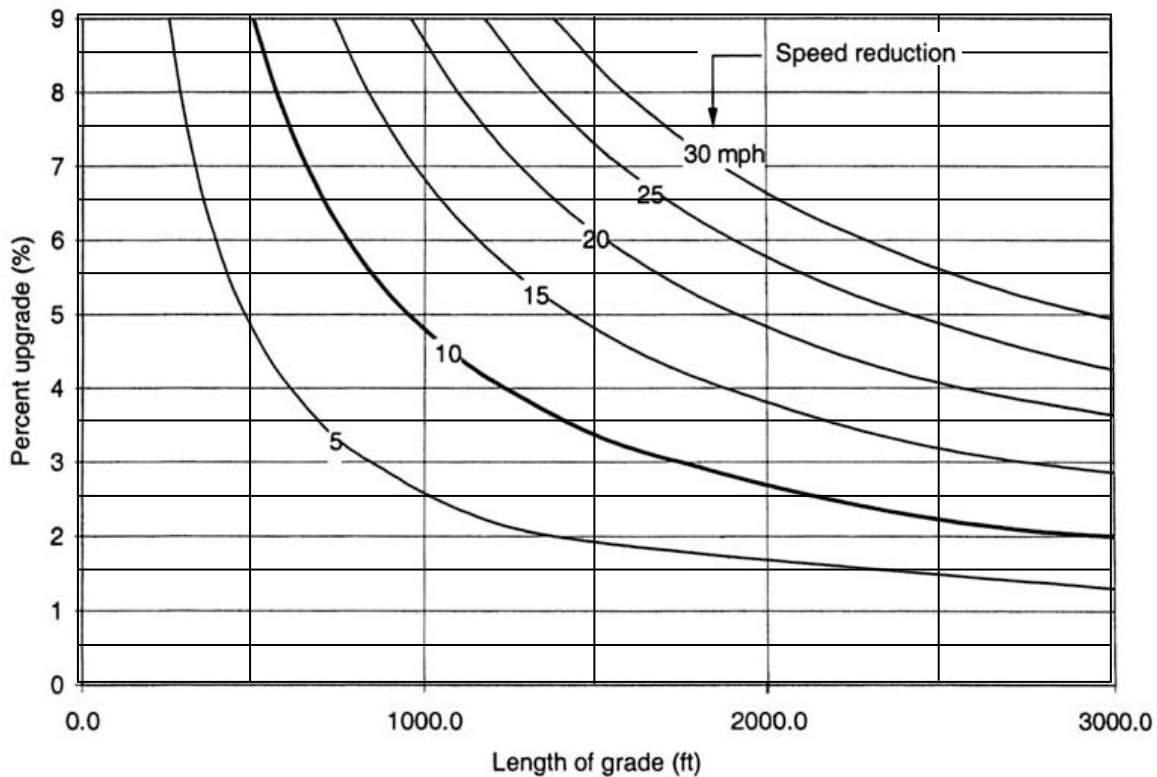

**Critical Lengths of Grade for Design, Assumed Typical Heavy Truck  
of 200 lb/hp, Entering Speed = 70 mph**

Source: 2011 AASHTO Greenbook, Figure 3-28.

### **C.5.c Vertical Curves**

Changes in grade should be connected by a parabolic curve (the vertical offset being proportional to the square of the horizontal distance). Vertical curves are required when the algebraic difference of intersecting grades exceeds the values given in Table 3 – 17 Maximum Change in Grade Without Using Vertical Curve. Table 3 – 18 Rounded K Values for Minimum Lengths Vertical Curves provides additional information.

The length of vertical curves on a crest, as governed by stopping sight distance, is obtained from Figure 3 – 3 Length of Crest Vertical Curve (Stopping Sight Distance). The minimum length for passing sight distance on crest vertical curves shall be based on the K-values as shown in Table

# DRAFT

3 – 19 Design Controls for Crest Vertical Curves (Passing Sight Distance).  
The minimum length of a sag vertical curve on open road conditions, as governed by vehicle headlight capabilities, is obtained from Figure 3 - 4 Length of Sag Vertical Curve (Headlight Sight Distance).

Wherever feasible, curves longer than the minimum should be considered to improve both aesthetic and safety characteristics.

**Table 3 – 17 Maximum Change in Grade Without Using Vertical Curve**

<b>Design Speed (mph)</b>	<b>20</b>	<b>25</b>	<b>30</b>	<b>35</b>	<b>40</b>	<b>45</b>	<b>50</b>	<b>55</b>	<b>60</b>	<b>65</b>	<b>70</b>
Maximum Change in Grade in Percent	1.20	1.10	1.00	0.90	0.80	0.70	0.60	0.50	0.40	0.30	0.20

**Table 3 – 18 Rounded K Values for Minimum Lengths Vertical Curves  
 (Stopping Sight Distance)**

(Based upon an eye height of 3.50 feet and an object height of 2 feet above the road surface)												
$L = KA$ L = Length of Vertical Curve, A = Algebraic Difference of Grades in Percent												
Design Speed (mph)	20	25	30	35	40	45	50	55	60	65	70	
K Values for Crest Vertical Curves	7	12	19	29	44	61	84	114	151	193	247	
K Values for Sag Vertical Curves	17	26	37	49	64	79	96	115	136	157	181	
<ul style="list-style-type: none"> <li>The length of vertical curve must never be less than three times the design speed of the highway.</li> <li>Curve lengths computed from the formula <math>L = KA</math> should be rounded upward when feasible.</li> <li>The minimum lengths of vertical curves to be used on collectors, arterials and freeways are shown in the table below:</li> </ul>												
Minimum Lengths for Vertical Curves on Collectors, Arterials, and Freeways (feet)												
Design Speed (mph)							50	60				70
Crest Vertical Curves (feet)							300	400				500
Sag Vertical Curves (feet)							200	300				400

**Figure 3 – 3 Length of Crest Vertical Curve (Stopping Sight Distance)**

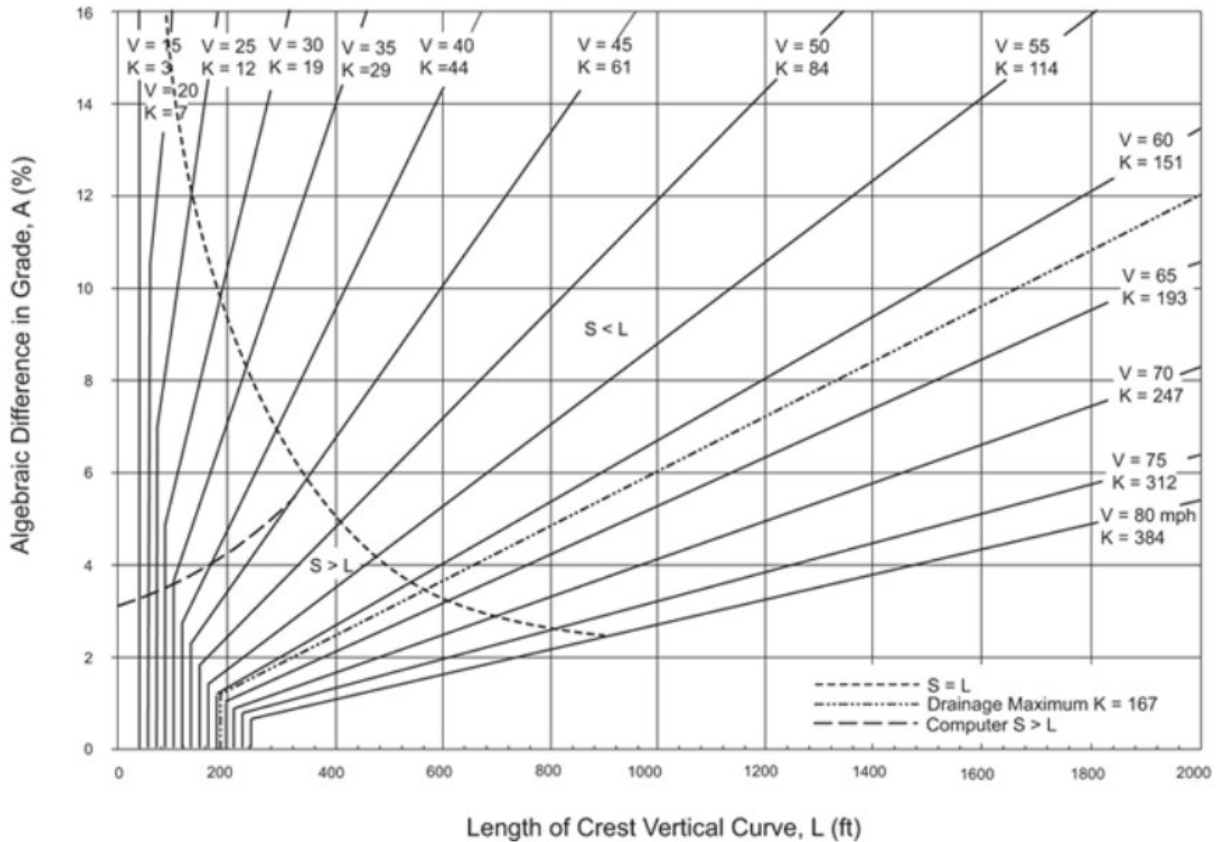

Source: Figure 3-43 Design Controls for Crest Vertical Curves – Open Road Conditions, 2011 AASHTO Greenbook

Lengths of crest vertical curves are computed from the formulas:

When S is less than L,  $L=AS^2/2158$

When S is greater than L,  $L=2S - (2158/A)$

A = Algebraic Difference In Grades In Percent

S = Sight Distance

L = Minimum Length of Vertical Curve In Feet



**Table 3 – 19 Design Controls for Crest Vertical Curves  
 (Passing Sight Distance)**

Based upon an eye height of 3.50 feet and an object height of <b>3.5</b> feet above the road surface.)		
$L = KA$ L = Length of Vertical Curve, A = Algebraic Difference of Grades in Percent		
Design Speed (mph)	Passing Sight Distance (feet)	Rate of Vertical Curvature, K <sup>a</sup>
20	400	57
25	450	72
30	500	89
35	550	108
40	600	129
45	700	175
50	800	229
55	900	289
60	1000	357
65	1100	432
70	1200	514
<sup>a</sup> Rate of vertical curvature, K, is the length of curve per percent algebraic difference in intersecting grades (A), $K = L/A$ .		

Source: Table 3-35 Design Controls for Crest Vertical Curves Based on Passing Sight Distance, 2011 AASHTO Greenbook.

For further information on both crest and sag vertical curves, see Section 3.4.6 Vertical Curves of the [AASHTO Greenbook \(2011\)](#).

**Figure 3 – 4 Length of Sag Vertical Curve (Open Road Conditions)**

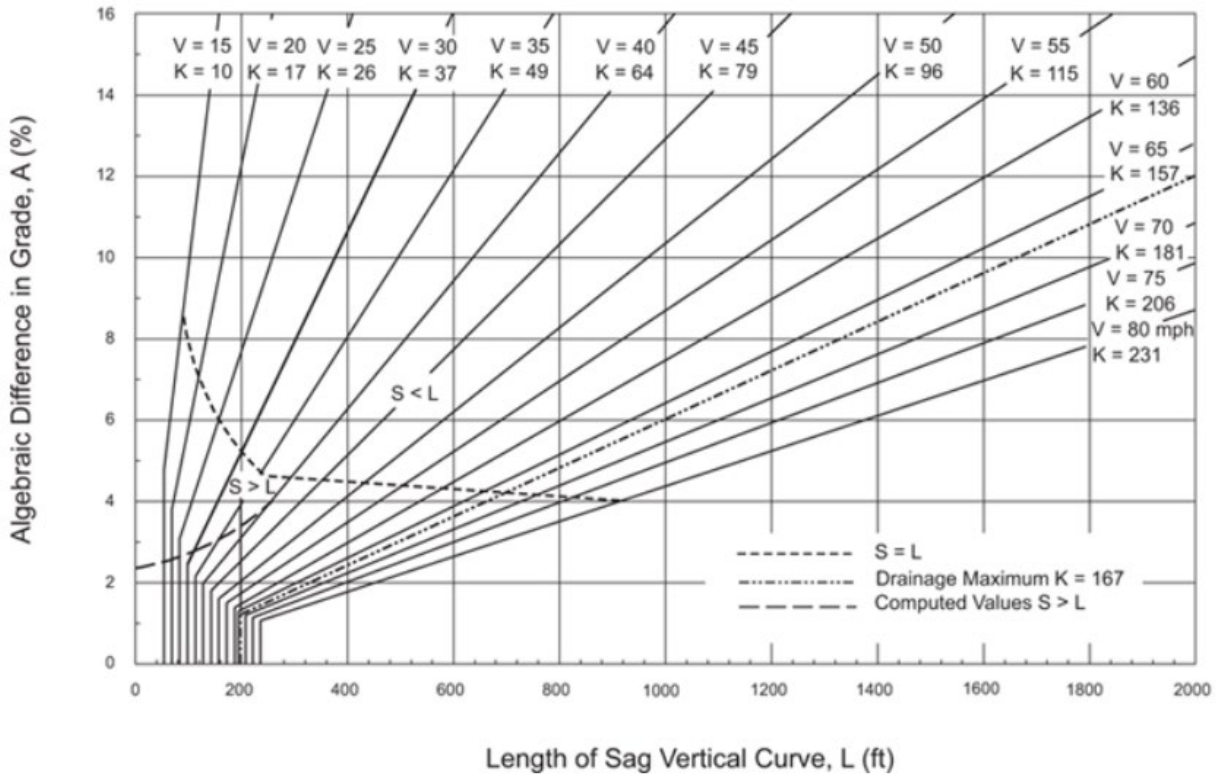

Source: Figure 3-44 Design Controls for Sag Vertical Curves – Open Road Conditions, 2011 AASHTO Greenbook.

Lengths of sag vertical curves are computed from the formulas:

When S is less than L,  $L = AS^2 / (400 + 3.5S)$

When S is greater than L,  $L = 2S - ((400 + 3.5S) / A)$

- L = Length of Sag Vertical Curve, feet
- A = Algebraic Difference in Grades, percent
- S = Light Beam Distance, feet

## C.6 Alignment Coordination

Horizontal and vertical alignment should not be designed independently. Poor combinations can spoil the good points of a design. Properly coordinated horizontal and vertical alignment can improve appearance, enhance community values, increase safety, and encourage uniform speed. Coordination of horizontal and vertical alignment should begin with preliminary design, during which stage adjustments can be readily made.

Proper combinations of horizontal alignment and profile can be obtained by engineering study and consideration of the following general controls:

- Curvature and grades should be in proper balance. Tangent alignment or flat curvature with steep grades and excessive curvature with flat grades are both poor design. A logical design is a compromise between the two conditions. Wherever feasible the roadway should "roll with" rather than "buck" the terrain.
- Vertical curvature superimposed on horizontal curvature, or vice versa, generally results in a more pleasing facility, but it should be analyzed for effect on driver's view and operation. Changes in profile not in combination with horizontal alignment may result in a series of disconnected humps to the driver for some distance.
- Sharp horizontal curvature should not be introduced at or near the top of a pronounced crest vertical curve. Drivers cannot perceive the horizontal change in alignment, especially at night. This condition can be avoided by setting the horizontal curve so it leads the vertical curve or by making the horizontal curve longer. Suitable design can be made by using design values well above the minimums.
- Sharp horizontal curvature should not be introduced at or near the low point of a pronounced sag vertical curve to prevent an undesirable distorted appearance. Vehicle speeds are often high at the bottom of grades and erratic operation may result, especially at night.
- On divided highways, variation of the median width and the use of independent vertical and horizontal alignment should be considered. Where right of way is available, a superior design without significant additional costs can result from the use of independent alignment.
- Horizontal alignment and profile should be made as flat as possible at interchanges and intersections where sight distance along both highways is important. Sight distances above the minimum are desirable at these locations.

- Alignment should be designed to enhance scenic views for the motorists.
- In residential areas, the alignment should be designed to minimize nuisance to the neighborhood.

## C.7 Cross Section Elements

The design of the street or highway cross section should be predicated upon the design speed, terrain, adjacent land use, classification, and the type and volume of traffic expected. The cross section selected should be uniform throughout a given length of street or highway without frequent or abrupt changes. See **Chapter 4 – Roadside Design** for design criteria for roadside design, clear zone, lateral offset, and roadside ditches located within the clear zone.

### C.7.a Number of Lanes

The number of travel lanes is determined by several interrelated factors such as capacity, level of service, and service volume. Further information on determining the optimum number of travel lanes can be found in [A Policy on Geometric Design of Highways and Streets \(AASHTO, 2011\)](#), and the [Highway Capacity Manual \(TRB, 2010\)](#).

### C.7.b Pavement

The paved surface of roadways shall be designed and constructed in accordance with the requirements set forth in **Chapter 5 - Pavement Design and Construction**.

#### C.7.b.1 Pavement Width

Minimum lane widths for travel lanes, speed change lanes, turn lanes and passing lanes are provided in Table 3 – 20 Minimum Lane Widths. The table applies to both divided and undivided facilities. For Information on parking lanes, see Section C.7.h Parking of this Chapter.

On existing multilane curbed streets where there is insufficient space for a separate bicycle lane, consideration should be given to using unequal-width lanes. In such cases, the wider lane is located on the outside (right). This provides more space for large vehicles that usually occupy that lane, provides more space for bicycles, and allows drivers to keep their vehicles at a greater distance from the right edge. See **Chapter 9 – Bicycle Facilities**.

# DRAFT

**Table 3 – 20 Minimum Lane Widths**

Facility		ADT (vpd)	Design Speed (mph)	Lane Width – (feet)		
				Travel Lanes <sup>1</sup>	Turn Lanes <sup>6</sup> (LT/RT/MD)	Passing Lanes
Freeway	Rural	All	All	12	--	--
	Urban	All	All	12	--	--
Arterial	Rural	All	All	12 <sup>9</sup>	12 <sup>9</sup>	12 <sup>9</sup>
	Urban	All	≥ 50	12	12	12
		All	≤ 45	11 <sup>3, 4</sup>	11 <sup>3, 4, 7</sup>	11 <sup>3, 4</sup>
Collector	Rural	> 1500	All	12 <sup>9</sup>	12 <sup>9</sup>	12 <sup>9</sup>
		401 to 1500	All	11 <sup>3, 4</sup>	11 <sup>3, 4</sup>	--
		≤ 400	≥ 50	11	11 <sup>7</sup>	--
	≤ 45		10	10	--	
	Urban	All	All	11 <sup>2, 3, 4</sup>	11 <sup>2, 7</sup>	--
Local	Rural	> 1500	All	12 <sup>9</sup>	12 <sup>9</sup>	12 <sup>9</sup>
		401 to 1500	All	11 <sup>3, 4</sup>	11 <sup>3, 4</sup>	--
		≤ 400	≥ 55	11 <sup>3</sup>	11 <sup>3, 4</sup>	--
			45 to 50	10	10	--
	≤ 40		9	9	--	
	Urban	All	All	10 <sup>2, 5</sup>	10 <sup>8</sup>	--
See Footnotes on next page						

## Footnotes

1. A minimum traveled way width equal to the width of two adjacent travel lanes (one way or two way) shall be provided on all rural facilities.
2. In industrial areas and where truck volumes are significant, 12' lanes should be provided, but may be reduced to 11' where right of way is constrained.
3. In constrained areas where truck volumes are low and **design** speeds are  $\leq$  35 mph, 10' lanes may be used.
4. On roadways with a transit route, a minimum of 11' outside lane width is required.
5. In residential areas where right of way is severely limited, 9' may be used.
6. Turn lane width in raised or grass medians shall not exceed 14'. Two-way left turn lanes should be 11 – 14' wide and may only be used on 3- and 5-lane typical sections with design speeds  $\leq$  40 mph. On projects with right of way constraints, the minimum width may be reduced to 10'. Two-way left turn lanes shall include sections of raised or restrictive median for pedestrian refuge.
7. Turn Lane width should be same as Travel Lane width. May be reduced to 10' where right of way is constrained.
8. Turn Lane width should be same as Travel Lane width. May be reduced to 9' where truck volumes are low.
9. For design speeds below 50 mph, lane widths of 11 feet are acceptable.

### **C.7.b.2 Traveled Way Cross Slope (not in superelevation)**

The selection of traveled way cross slope should be a compromise between meeting the drainage requirements and providing for smooth vehicle operation. The recommended traveled way cross slope is 0.02 feet per foot. When three lanes in each direction are necessary, the outside lane should have a cross slope of 0.03 feet per foot. The cross slope shall not be less than 0.015 feet per foot or greater than 0.04 feet per foot. The change in cross slope between adjacent through travel lanes should not exceed 0.04 feet per foot.

## C.7.c Shoulders

The primary functions of a shoulder are to provide emergency parking for disabled vehicles and an alternate path for vehicles during avoidance or other emergency maneuvers. In order to fulfill these functions satisfactorily, the shoulder should have adequate stability and surface characteristics. The design and construction of shoulders shall be in accordance with the requirements given in **Chapter 5 - Pavement Design and Construction**.

Shoulders should be provided on all streets and highways incorporating open drainage. The absence of a contiguous emergency travel or storage lane is not only undesirable from a safety standpoint, but also is disadvantageous from an operations viewpoint. Disabled vehicles that must stop in a through lane impose a severe safety hazard and produce a dramatic reduction in traffic flow. Shoulders should be free of abrupt changes in slope, discontinuities, soft ground, or other hazards that would prevent the driver from retaining or regaining vehicle control.

Paved outside shoulders are required for rural high speed multilane highways and freeways. They provide added safety to the motorist, public transit and pedestrians, for accommodation of bicyclists, reduced shoulder maintenance costs, and improved drainage.

### C.7.c.1 Shoulder Width

A shoulder is the portion of the roadway contiguous with the traveled way that accommodates stopped vehicles, emergency use, and provides lateral support of subbase, base and surface courses. In some cases, the shoulder may also accommodate pedestrians or bicyclists. Shoulders may be surfaced either full or partial width and include turf, gravel, shell, and asphalt or concrete pavements.

The minimum width of outside and median shoulders is provided in Table 3 – 21 Minimum Shoulder Widths for Flush Shoulder Highways. Shoulders for two-lane, two-way highways are based upon traffic volumes. Shoulder widths for multi-lane highways are based upon the number of travel lanes in each direction. Where bicyclists or pedestrians are to be accommodated on the shoulder, a minimum usable width of 4 feet is required (5 feet if adjacent to a barrier). On approaches to narrow bridges where the paved shoulder is reduced, the [FDOT's – the Department's Standard Plans Index 700-106](#) provide information on signing and marking the approaching

shoulder.

**Table 3 – 21 Minimum Shoulder Widths for Flush Shoulder Highways**

**Two Lane Undivided**

Design Speed (mph)	Average Daily Traffic (2 – Way)		
	0 - ≤400	401 - 750	>750 -
All	2 feet	6 feet	8 feet

**Multilane Divided**

Number of Lanes Each Direction	Shoulder Width (feet)			
	Outside		Median	
	Roadway	Bridge	Roadway	Bridge
2	8 (min.)	8	4 (min.)	4
3 or more	10 (min.)	10	6 (min.)	6



## C.7.c.2 Shoulder Cross Slope

The shoulder serves as a continuation of the drainage system; therefore, the shoulder cross slope should be somewhat greater than the adjacent traffic lane. The cross slope of shoulders should be within the range given in Table 3 – 22 Shoulder Cross Slope.

**Table 3 – 22 Shoulder Cross Slope**

	Shoulder Type		
	Paved	Gravel or Crushed Rock	Turf
Shoulder Cross Slope (Percent)	2 to 6%	4 to 6%	6 to 8%

Notes: 1. Existing shoulder cross slope (paved and unpaved)  $\leq$  12% may remain.

Source – 2011 AASHTO Greenbook, Section 4.4.3 Shoulder Cross Sections.

Whenever possible, shoulders should be sloped away from the traveled way to aid in their drainage. The combination of shoulder cross slope and texture should be sufficient to promote rapid drainage and to avoid retention of surface water. The maximum algebraic difference between the traveled way and adjacent shoulder should not be greater than 0.07 feet per foot. Shoulders on the outside of superelevated curves should be rounded (vertical curve) to avoid an excessive break in cross slope and to divert a portion of the drainage away from the adjacent traveled way.

## C.7.d Sidewalks and Shared Use Paths

The design of sidewalks is affected by many factors, including traffic characteristics, pedestrian volume, roadway type, and other design elements. **Chapter 8 - Pedestrian Facilities** and Chapter 9 – Bicycle Facilities of this Manual and A Policy on Geometric Design of Highways and Streets (AASHTO, 2011), present the various factors that influence the design of sidewalks and other pedestrian facilities.

# DRAFT

Sidewalks and/or shared use paths should be constructed in conjunction with new construction and major reconstruction in or within one mile of an urban area. As a general rule, sidewalks should be constructed on both sides of the roadway. Exceptions may be made where physical barriers (e.g., a canal paralleling one side of the roadway) would substantially reduce the expectation of pedestrian use of one side of the roadway. Also, if only one side is possible, sidewalks should be available on the same side of the road as transit stops or other pedestrian generators.

The decision to construct a sidewalk or shared use path in a rural area should be based on engineering judgment, after observation of existing pedestrian traffic or ~~and~~ expectation of additional demand. ~~should a sidewalk be made available.~~

Sidewalks and shared use paths shall be constructed as defined in this Manual. **Chapter 8 – Pedestrian Facilities**, **Chapter 10 – Maintenance and Resurfacing** and **Section C.10.a.3 – Sidewalks and Curb Ramps** of this chapter provide additional detailed information. **AASHTO’s Guide for the Planning, Design and Operation of Pedestrian Facilities (2004)**, and **Section 4.17.1 Sidewalks of AASHTO’s Policy on Geometric Design of Highways and Streets (2011)** provide additional information.

The [Highway Capacity Manual, Volume 3, Chapter 23, Off-Street Pedestrian and Bicycle Facilities \(2010\)](#) includes further information on how optimal widths can be determined.

~~Curb ramps shall be provided at all intersections with curb (**Section 336.045 (3), Florida Statutes**). In addition to the design criteria provided in this chapter, the **2006 Americans with Disabilities Act Standards for Transportation Facilities** as required by 49 C.F.R. 37.41 or 37.43 and the **2012 Florida Accessibility Code for Building Construction** as required by 61G20-4.002 impose additional requirements for the design and construction of pedestrian facilities.~~

## C.7.e Medians

Median separation of opposing traffic lanes provides a beneficial safety feature and should be used wherever feasible. Separation of the opposing traffic also reduces the problem of headlight glare, thus improving safety and comfort for night driving. When sufficient width of medians is available, some landscaping is also possible.

The use of medians often aids in the provision of drainage for the roadway surface, particularly for highways with six or more traffic lanes. The median also provides a vehicle refuge area, improves the safety of pedestrian crossings, provides a logical location for left turn auxiliary lanes, and provides the means for future addition of traffic lanes and mass transit. In many situations, the median strip aids in roadway delineation and the overall highway aesthetics.

Median separation is required on the following streets and highways:

- Freeways
- All streets and highways, rural and urban, with 4 or more travel lanes and with a design speed of 40 mph or greater

Median separation is desirable on all other multi-lane roadways to enhance pedestrian crossings.

The nature and degree of median separation required is dependent upon the design speed, traffic volume, adjacent land use, and the frequency of access. There are basically two approaches to median separation. The first is the use of horizontal separation of opposing lanes to reduce the probability of vehicles crossing the median into incoming traffic. The second method is to attempt to limit crossovers by introducing a positive median barrier structure.

In rural areas, the use of wide medians is not only aesthetically pleasing, but is often more economical than barriers. In urban areas where space and/or economic constraints are severe, the use of barriers is permitted to fulfill the requirements for median separation.

Uncurbed medians should be free of abrupt changes in slope, discontinuities, soft ground, or other hazards that would prevent the driver from retaining or regaining control of the vehicle. Consideration should be given to increasing the width and decreasing the slope of medians on horizontal curves. The requirements for a hazard free median environment are given in **Chapter 4 - Roadside Design**, and shall be followed in the design and construction of medians.

### **C.7.e.1 Type of Median**

A wide, gently depressed median is the preferred design. This type

allows a reasonable vehicle recovery area and aids in the drainage of the adjacent shoulders and travel lanes. Where space and drainage limitations are severe, narrower medians, flush with the roadway, or raised medians, are permitted. Raised medians should be used to support pedestrian crossings of multi-laned streets and highways.

### **C.7.e.2 Median Width**

The median width is defined as the horizontal distance between the inside (median) edge of travel lanes of the opposing roadways. The selection of the median width for a given type of street or highway is primarily dependent on design speed and traffic volume. Since the probability of crossover crashes is decreased by increasing the separation, medians should be as wide as practicable. Median widths in excess of 30 feet to 35 feet reduce the problem of disabling headlight glare from opposing traffic.

The minimum permitted widths of freeway medians are given in Table 3 – 23 Minimum Median Width. Where the expected traffic volume is heavy, the widths should be increased over these minimum values. Median barriers shall be used on freeways when these minimum values are not attainable.

The minimum permitted median widths for multi-lane rural highways are also given in Table 3 – 23 Minimum Median Width. On urban streets, the median widths shall not be less than the values given in Table 3 – 23. Where median openings or access points are frequent, the median width should be increased.

The minimum median widths given in these Tables may have to be increased to meet the requirements for cross slopes, drainage, and turning movements (C.9 Intersection Design, this chapter). The median area should also include adequate additional width to allow for expected additions of through lanes and left turn lanes. Where the median width is sufficient to produce essentially two separate, independent roadways, the left side of each roadway shall meet the requirements for roadside clear zone. Changes in the median width should be accomplished by gently flowing horizontal alignment of one or both of the separate roadways.

**Table 3 – 23 Minimum Median Width**

Type of Facility	Width (feet)
<b>Freeways</b>	
Freeways, Without Barrier	---
Design Speed $\geq$ 60 mph	60
Design Speed $<$ 60 mph	40
All, With Barrier, All Design Speeds	26 <sup>1</sup>
<b>Arterial and Collectors</b>	
Design Speed $\geq$ 50 mph	40
Design Speed $\leq$ 45 mph	22 <sup>2</sup>
Paved and Painted for Left Turns	See Table 3 – 20 Minimum Lane Widths
<p>Median width is the distance between the inside (median) edge of the travel lane of each roadway.</p> <p>Footnotes:</p> <ol style="list-style-type: none"> <li>1. Based on 2 ft. wide, concrete median barrier and 12 ft. shoulder.</li> <li>2. On projects where right of way is constrained, the minimum width may be reduced to 19.5 ft. for design speeds = 45 mph, and to 15.5 ft. for design speeds <math>\leq</math> 40 mph.</li> </ol>	

### C.7.e.3 Median Slopes

A vehicle should be able to transverse a median without turning over and with sufficient smoothness to allow the driver a reasonable chance to control the vehicle. The transition between the median slope and the shoulder (or pavement) slope should be smooth, gently rounded, and free from discontinuities.

The median cross slope should not be steeper than 1:6 (preferably not steeper than 1:10). The depth of depressed medians may be controlled by drainage requirements. Increasing the width of the median, rather than increasing the cross slope, is the proper method for developing the required median depth.

Longitudinal slopes (median profile parallel to the roadway) should be shallow and gently rounded at intersections of grade. The longitudinal slope, relative to the roadway slope, shall not exceed a ratio of 1:10 and preferably 1:20. The change in longitudinal slope shall not exceed 1:8 (change in grade of 12.5 %).

### C.7.e.4 Median Barriers

See *Chapter 4 – Roadside Design* for criteria on median barriers. The *AASHTO Roadside Design Guide* provides additional information and guidelines on the use of median barriers.

### C.7.f Islands

An island is a defined area between traffic lanes used for control of vehicle movements. Most islands combine two or more of these primary functions:

1. Channelization — To control and direct traffic movement, usually turning.
2. Division — To divide opposing or same direction traffic streams, usually through movements; and
3. Refuge — To provide refuge for pedestrians.

Islands generally are either elongated or triangular in shape and situated in areas unused for vehicle paths. Islands should be located and designed to offer little obstruction to vehicles and be commanding enough that motorists

will not drive over them. The placement of mast arms in channelizing islands is discouraged. Mast arms are not permitted in median islands.

The dimensions and details depend on the intersection design as illustrated in Figure 3 – 5 General Types and Shapes of Islands and Medians. They should conform to the general principles that follow.

**Figure 3 – 5 General Types and Shapes of Islands and Medians**

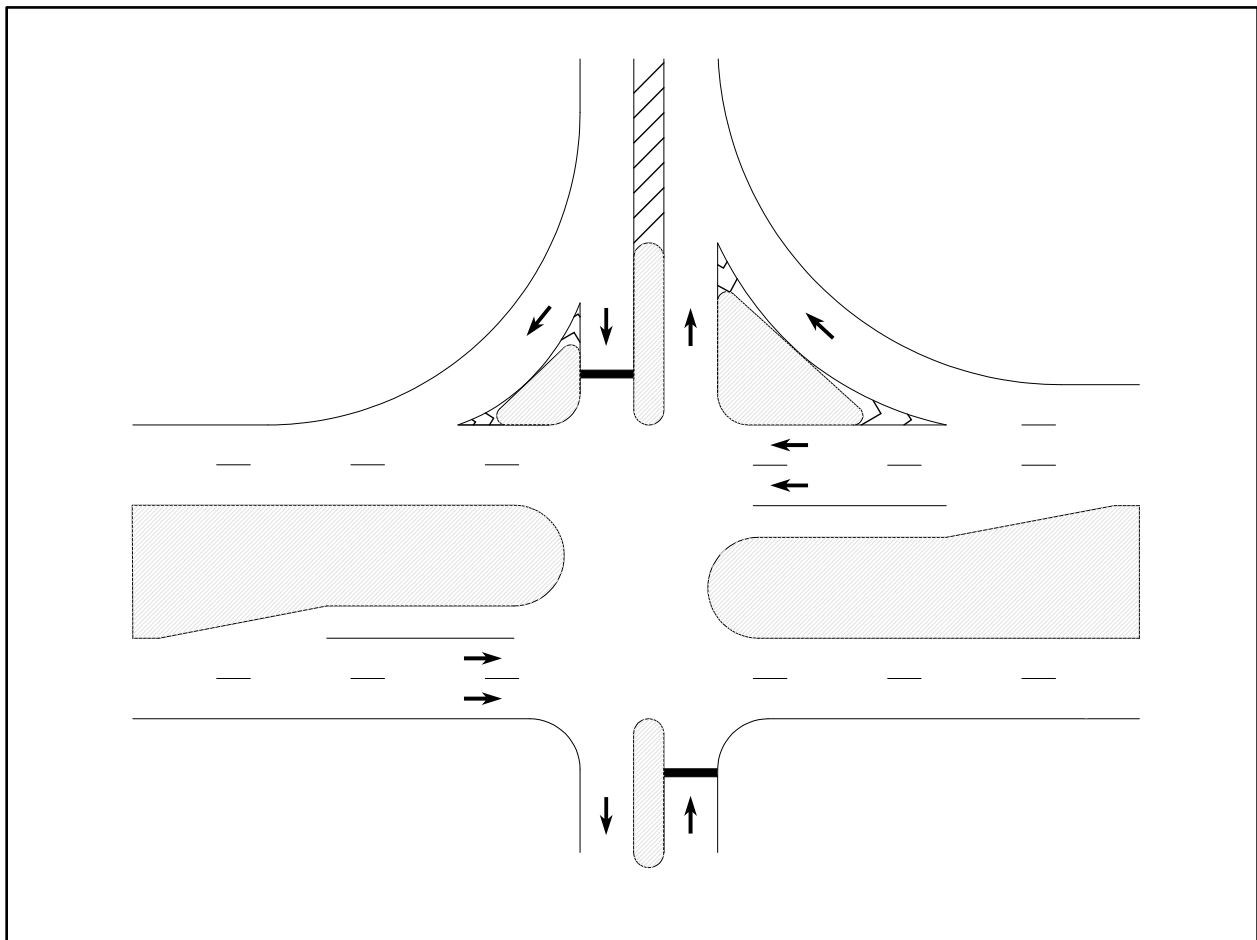

# DRAFT

Curbed islands are sometimes difficult to see at night. Where curbed islands are used, the intersection should have fixed-source lighting or appropriate delineation. Under certain conditions, painted, flush medians and islands or traversable type medians may be preferable to the raised curb type islands. These conditions include the following:

- Lightly developed areas that will not be considered for access management.
- Intersections where approach speeds are relatively high.
- Areas where there is little pedestrian traffic.
- Areas where fixed-source lighting is not provided.
- Median or corner islands where signals, signs, or luminaire supports are not needed; and
- Areas where extensive development exists and may demand left-turn lanes into many entrances.

Painted islands may be used at the traveled way edge. At some intersections, both curbed and painted islands may be desirable. All pavement markings should be reflectorized. The use of thermoplastic striping, raised dots, spaced and raised retroreflective markers, and other forms of long-life markings also may be desirable. See **Section 9.6.3** of the [2011 AASHTO Greenbook](#) and the [MUTCD, Part 3](#) for additional information on the design and marking of islands.

The central area of large channelizing islands in most cases has a turf or other vegetative cover. As space and the overall character of the highway determine, low plant material may be included, but it should not obstruct sight distance. Ground cover or plant growth, such as turf, vines, and shrubs, can be used for channelizing islands and provides excellent contrast with the paved areas, assuming ~~that~~ the ground cover is cost-effective and can be properly maintained. The [Index 546 of The Department FDOT Design Manual, Chapter 212 Intersections Design Standards](#) provides additional information on designing landscaping in medians or at intersections.



Small, curbed islands may be mounded, but where pavement cross slopes are outward, large islands should be depressed to avoid draining water across the pavement. For small, curbed islands and in areas where growing conditions are not favorable, some type of paved surface may be used on the island.

Careful consideration should be given to the location and type of plantings. Plantings, particularly in narrow islands, may create problems for maintenance activities. Plantings and other landscaping features in channelization areas may constitute roadside obstacles and should be consistent with the requirements in Section C.9.b Sight Distance. The [AASHTO Roadside Design Guide \(2011\)](#) provides additional information on landscaping of islands.

### **C.7.f.1 Channelizing Islands**

Channelizing islands may be of many shapes and sizes, depending on the conditions and dimensions of the intersection. A common form is the corner triangular shape that separates right-turning traffic from through traffic. Central islands may serve as a guide around which turning vehicles operate.

Channelizing islands should be placed so that the proper course of travel is immediately obvious, easy to follow, and of unquestionable continuity. Where islands separate turning traffic from through traffic, the radii of curved portions should equal or exceed the minimum for the turning speeds expected. Curbed islands generally should not be used in rural areas and at isolated locations unless the intersection is lighted and curbs are delineated.

Islands should be sufficiently large to command attention, with 100 ft<sup>2</sup> preferred. The smallest curbed corner island should have an area of at least 50 ft<sup>2</sup> for urban and 75 ft<sup>2</sup> for rural intersections. A corner triangular island should be at least 15 feet on a side (12 ft. minimum) after the rounding of corners.

While mast arms are discouraged in channelizing islands, when they are used the minimum lateral offset as shown in Chapter 4, Roadside Design Table 4 – 2 Lateral Offset shall be provided. Mast arm foundation diameters vary from 3.5 feet to 5.0 feet. The minimum

# DRAFT

lateral offset for 45 mph and less should be based on minimum offset to a hazard from curb face – 4 feet standard, 1.5 feet absolute minimum.

Details of curbed corner island designs used in conjunction with turning roadways are shown in Figures 3 – 6 Channelization Island for Pedestrian Crossings (Curbed), 3 – 7 Details of Corner Island for Turning Roadways (Curbed) and 3 – 8 Details of Corner Island for Turning Roadways (Flush Shoulder). The approach corner of each curbed island is designed with an approach nose treatment.

Further information on the pavement markings that can be used with islands can be found in ~~of the Department~~ the [FDOT's \*Standard Plans, Index 711-001\*](#).

**Figure 3 – 6 Channelization Island for Pedestrian Crossings (Curbed)**

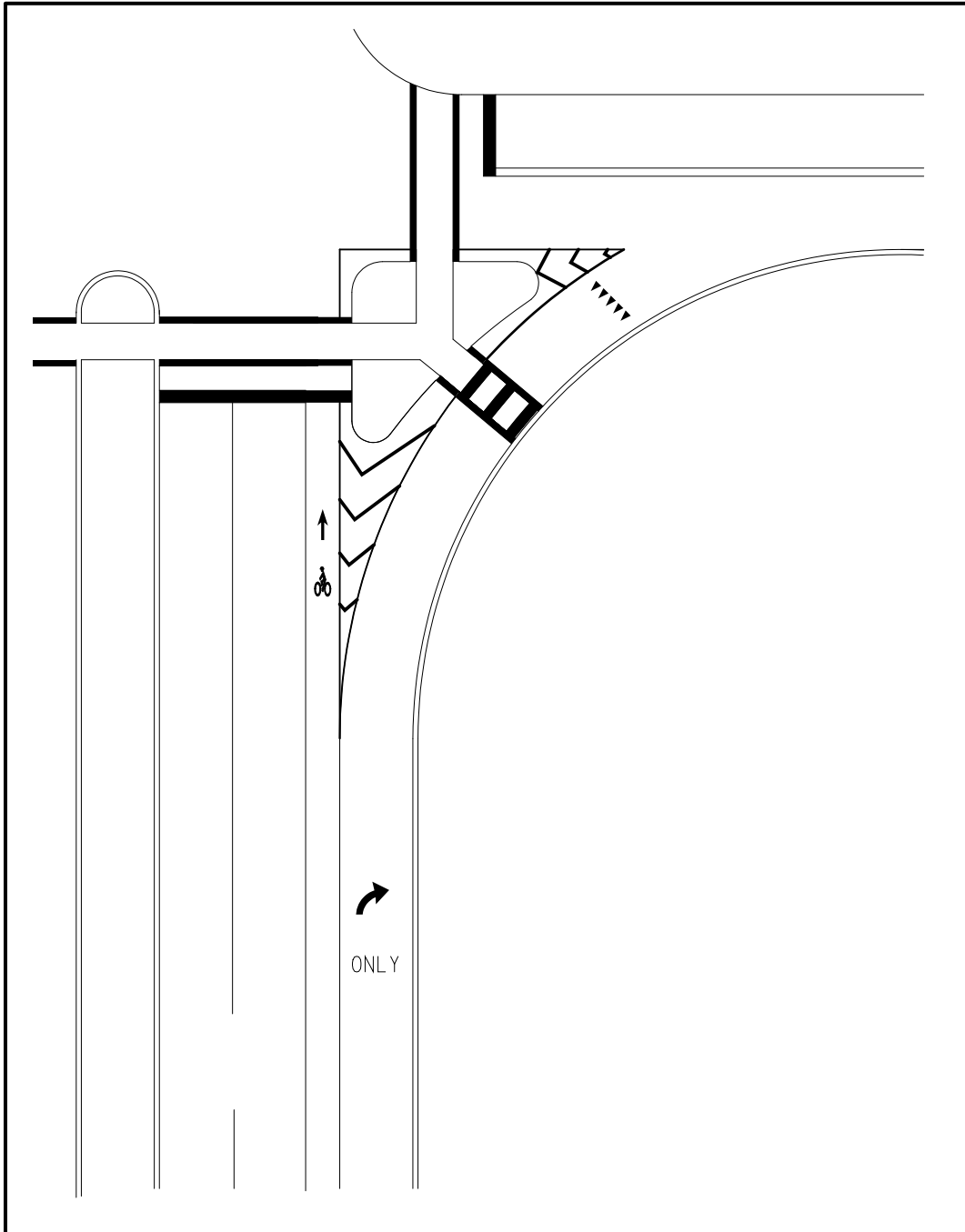

**Figure 3 – 7 Details of Corner Island for Turning Roadways (Curbed)**

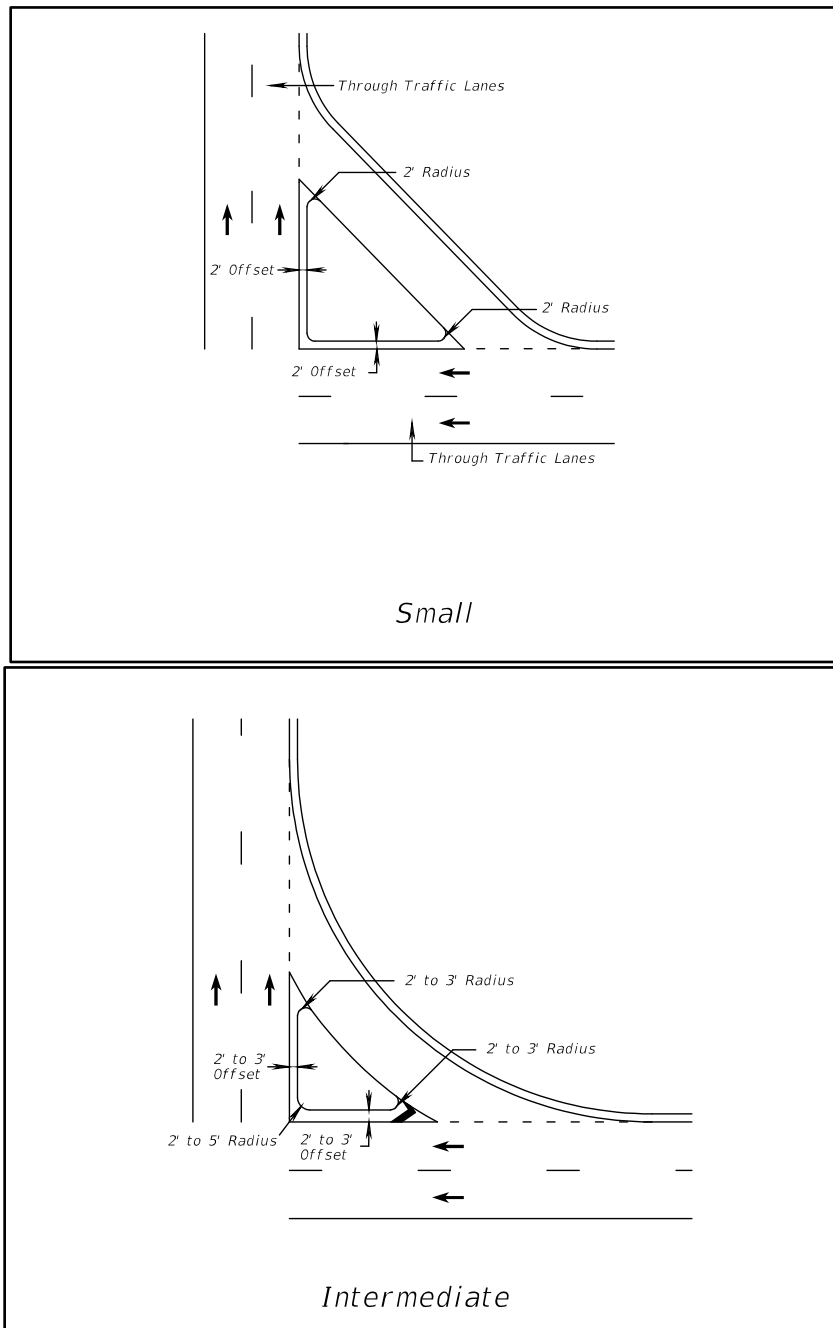

**Figure 3 – 8 Details of Corner Island for Turning Roadways (Flush Shoulder)**

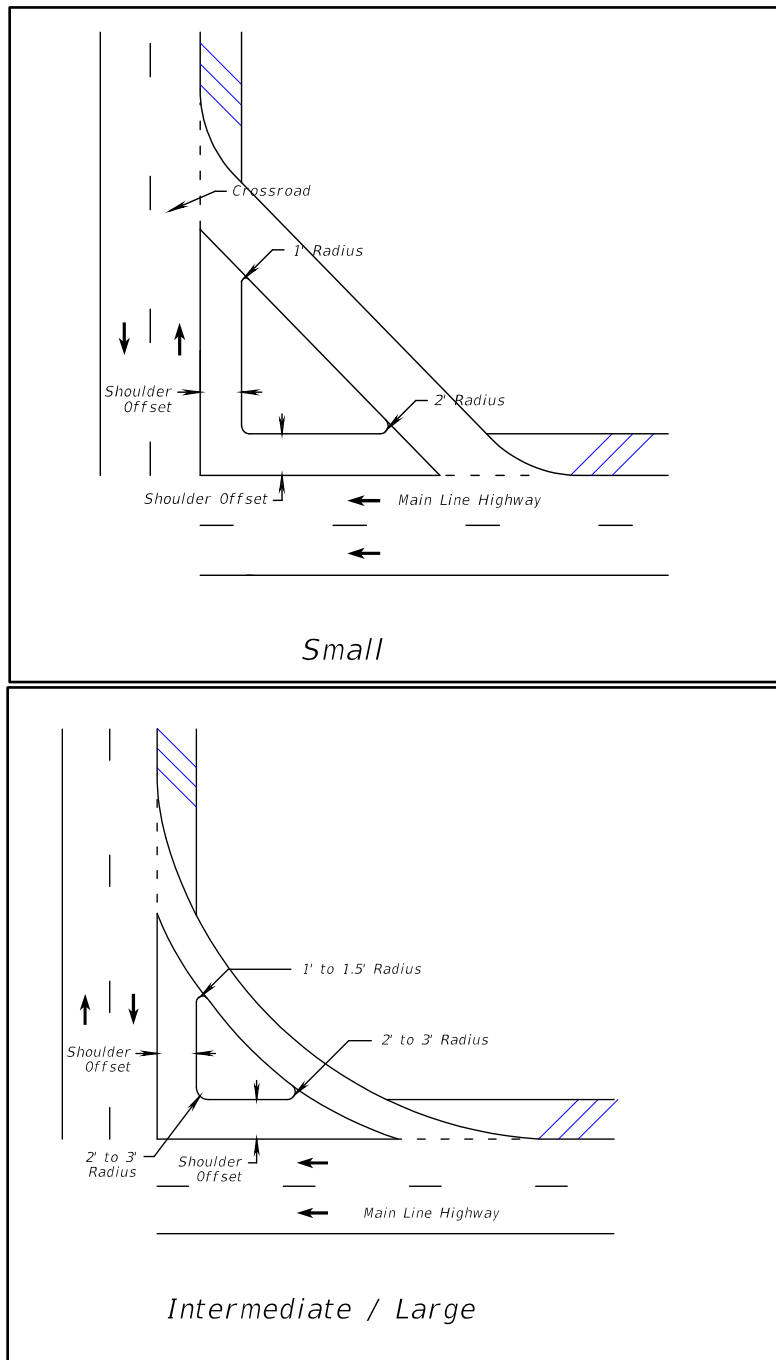

## C.7.f.2 Divisional Islands

Divisional islands often are introduced on undivided highways at intersections. They alert drivers to the crossroad ahead and regulate traffic through the intersection. These islands are particularly advantageous in controlling left turns at skewed intersections and at locations where separate roadways are provided for right-turning traffic.

Widening a roadway to include a divisional island should be done in such a manner that the proper paths to follow are unmistakably evident to drivers. The alignment should require no appreciable conscious effort in vehicle steering.

Elongated or divisional islands should be not less than 4 feet wide and 20 to 25 feet long. In general, introducing curbed divisional islands at isolated intersections on high-speed highways is undesirable unless special attention is directed to providing high visibility for the islands. Curbed divisional islands introduced at isolated intersections on high-speed highways should be 100 feet or more in length. When situated in the vicinity of a high point in the roadway profile or at or near the beginning of a horizontal curve, the approach end of the curbed island should be extended to be clearly visible to approaching drivers.

Where an island is introduced at an intersection to separate opposing traffic on a four-lane road or on a major two-lane highway carrying high volumes, two full lanes should be provided on each side of the dividing island (particularly where future conversion to a wider highway is likely). In other instances, narrower roadways may be used. For moderate volumes, roadway widths shown under Case II (one-lane, one-way operation with provision for passing a stalled vehicle) in Table 3 – 34 Derived Pavement Widths for Turning Roadways for Different Design Vehicles are appropriate. For light volumes and where small islands are needed, widths on each side of the island corresponding to Case I in Table 3 – 34 may be used.

**Figure 3 – 9 Alignment for Divisional Islands at Intersections**

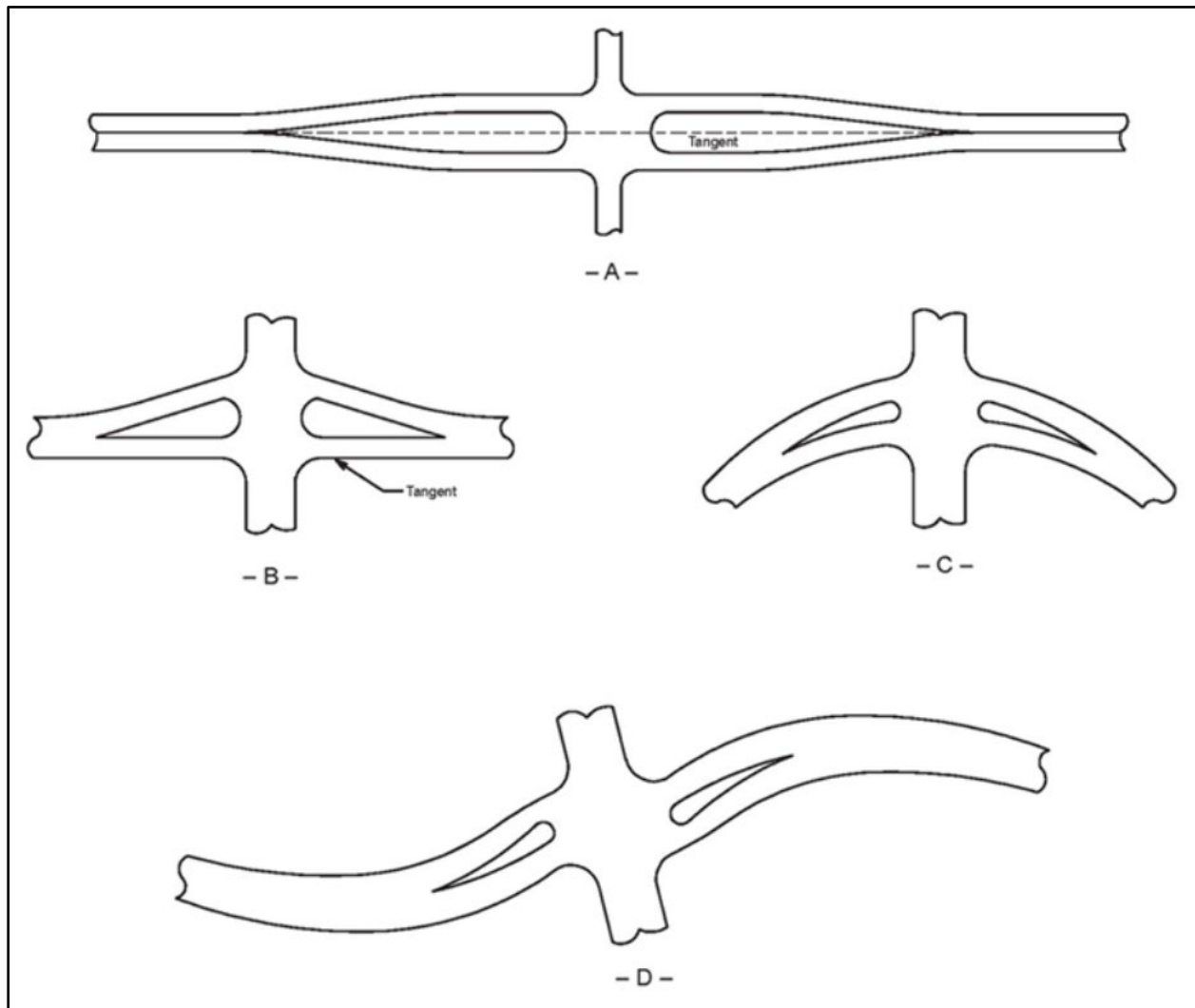

### C.7.f.3 Refuge Islands

A refuge island for pedestrians at or near a crosswalk or shared use path crossing aids pedestrians and bicyclists who cross the roadway. Raised-curb corner islands and center channelizing or divisional islands can be used as refuge areas. Refuge islands for pedestrians and bicyclists crossing a wide street, for loading or unloading transit riders, or for wheelchair ramps are used primarily in urban areas. Figure 3 – 10 Pedestrian Refuge Island, Figure 3 – 11 Pedestrian Crossing with Refuge Island (Yield Condition), and Figure 3 – 12

# DRAFT

Pedestrian Crossing with Refuge Island (Stop Condition) show divisional islands that support a midblock crosswalk with stop and yield conditions. The distance A shown in the figures is based upon the [MUTCD](#), and shown following the figures.

The location and width of crosswalks, the location and size of transit loading zones, and the provision of curb ramps influence the size and location of refuge islands. Refuge islands should be a minimum of 6 feet wide. Pedestrians and bicyclists should have a clear path through the island and should not be obstructed by poles, sign posts, utility boxes, etc. Sidewalk and shared use path curb ramps in islands shall meet the requirements found in **Section C.10.a.3** of this chapter and **Chapter 8 – Pedestrian Facilities**. Curb ramps that are part of a shared use path shall also meet the requirements of **Chapter 9 – Bicycle Facilities**.

**Figure 3 – 10 Pedestrian Refuge Island**



3—10—Pedestrian Refuge Island

Figure



North Main Street, Gainesville, FL

Figure 3 – 11 Pedestrian Crossing with Refuge Island (Yield Condition)

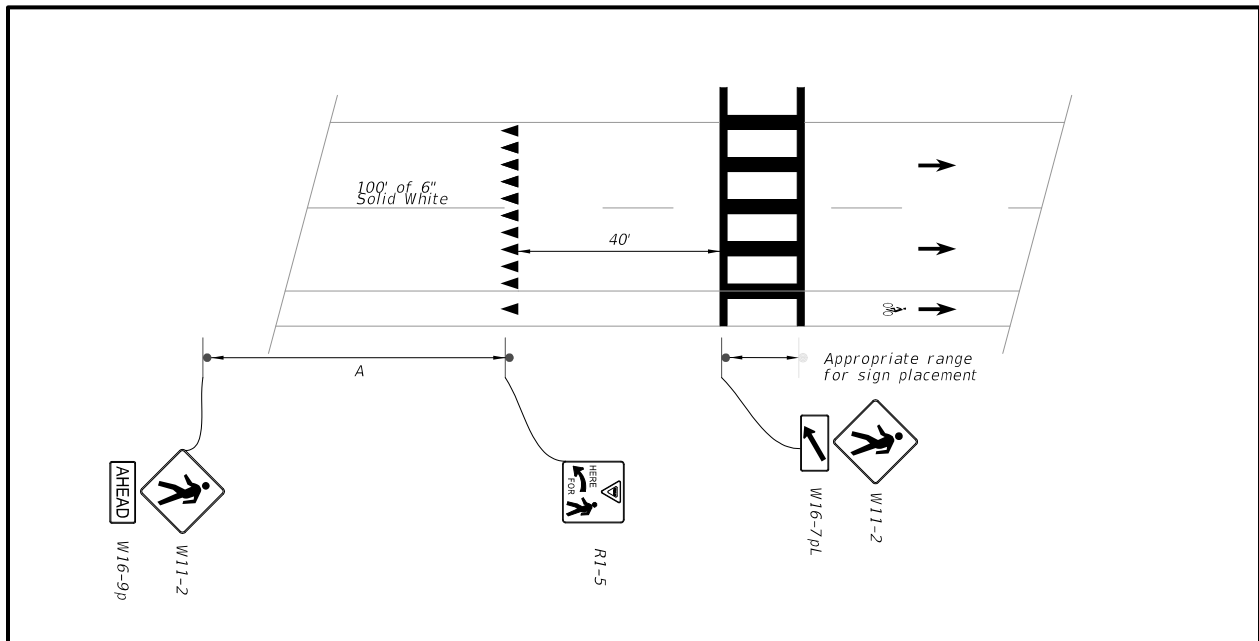

**Figure 3 – 12 Pedestrian Crossing with Refuge Island (Stop Condition)**

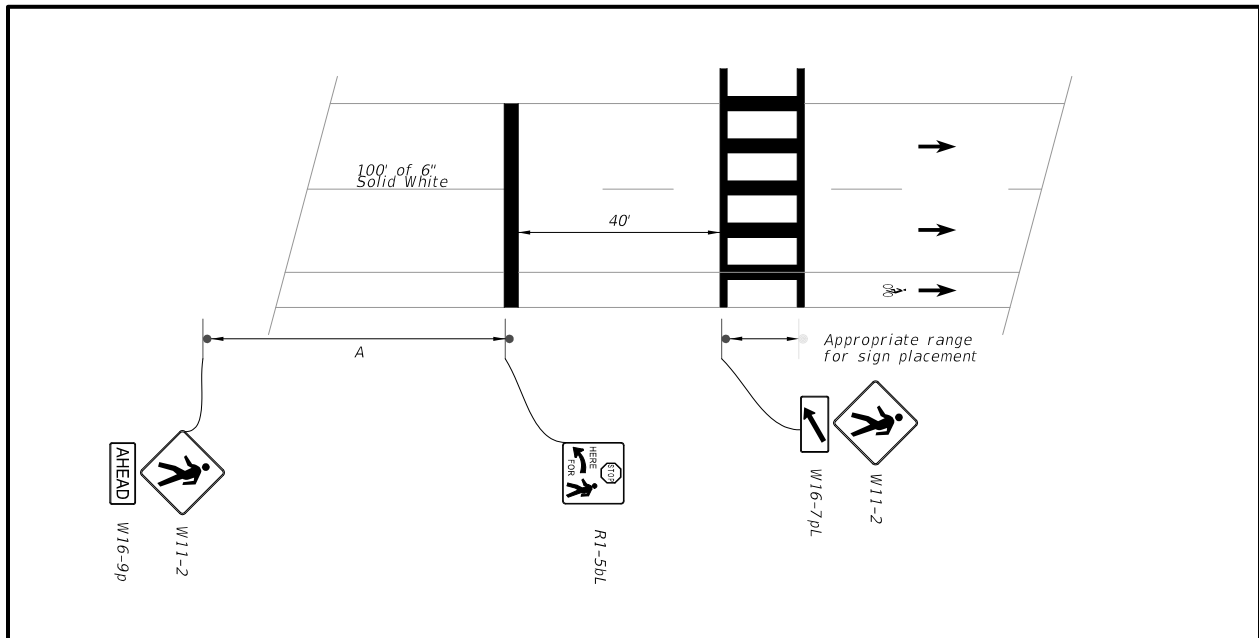

Note: 1. See following page for distance A.

# DRAFT

The distance A shown in **Figures 3 – 11** and **3 – 12** for the advance warning sign should be:

Posted Speed (mph)	Advance Placement Distance (feet)
25 or Less	100
26 to 35	100
36 to 45	175

Source: 2009 MUTCD, with 2012 Revisions, Table 2C-4. Guidelines for Advance Placement of Warning Signs. Typical condition is the warning of a potential stop condition.

An example of a pedestrian crossing through a refuge island is shown in Figure 3 – 13 Pedestrian Crossing in Refuge Island. Other options are shown in [the Department's FDOT's Standard Plans 522-002 Detectable Warnings and Sidewalk Curb Ramps.](#)

**Figure 3 – 13 Pedestrian Crossing in Refuge Island**

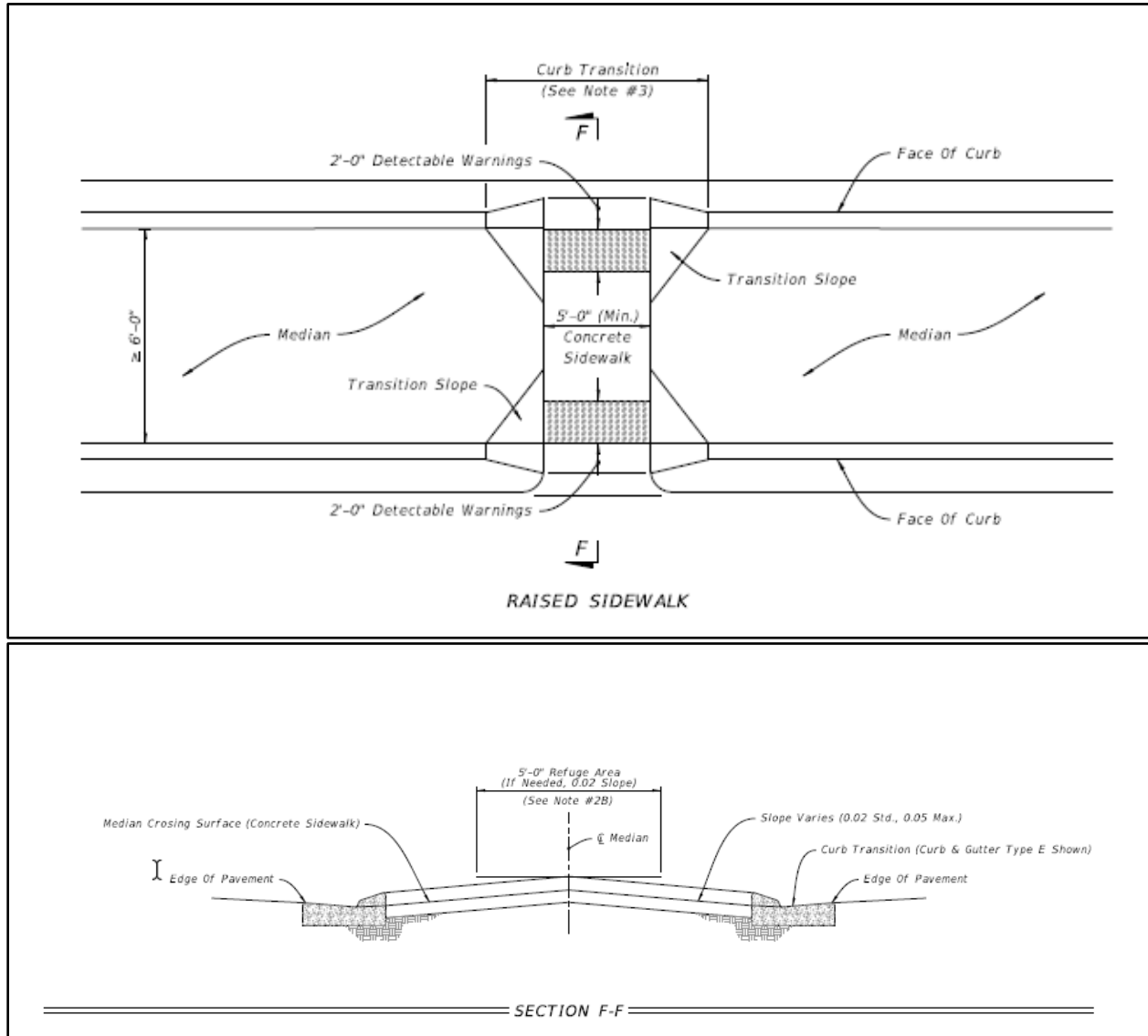

## C.7.g Curbs

Curbs may be used to provide drainage control and to improve delineation of the roadway. Curbs are generally designed with a gutter to form a combination curb and gutter section. In Florida, the standard curb of this type is 6 inches in height. See Figure 3 – 14 Standard Detail for FDOT Type F and E Curbs for examples of sloping curbs. These curbs are not to be used on facilities with design speeds greater than 45 mph. See **Chapter 4 – Roadside Design** for additional design criteria on the use of curbs.

Figure 3 – 14 Standard Detail for FDOT Type F and E Curbs

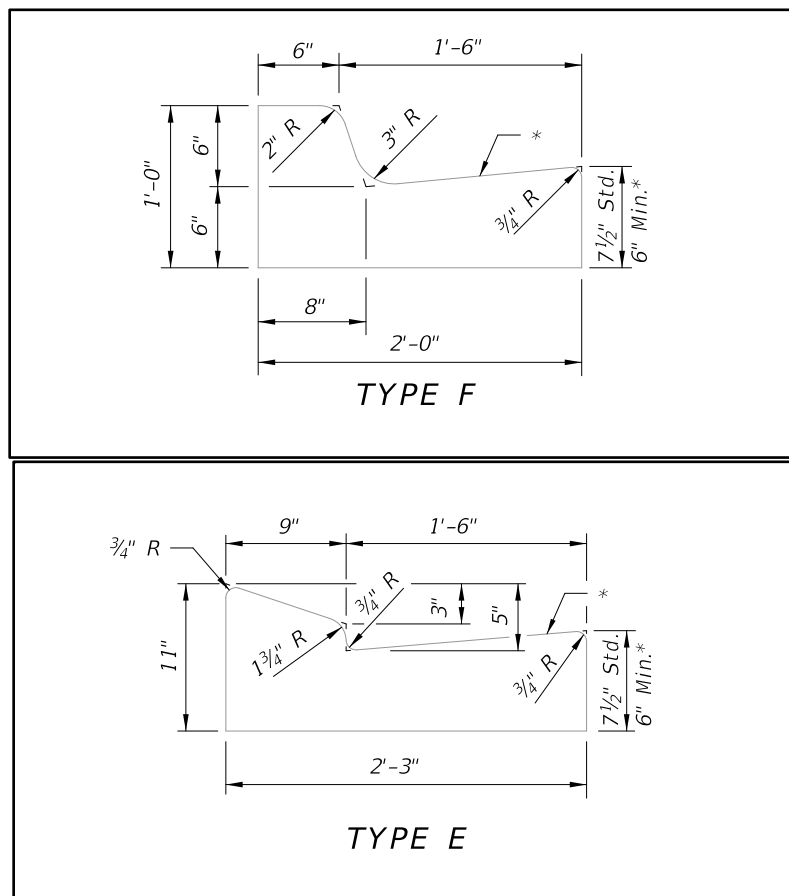

## C.7.h Parking

Where parking is needed, and adequate off-street parking facilities are not available or feasible, on-street parking may be necessary. On-street parking is allowed on facilities with posted speeds of 35 mph or less. It is typically located at the outside edge of the roadway between the traveled way and the sidewalk. On streets with a posted speed of 25 mph or less, parking may be located within the median in downtown urban centers. On-street parking may be either parallel or angle (traditional or reverse).

On-street parking may help manage traffic speeds, and provides separation between the sidewalk and travel lanes. It may also decrease through capacity, reduce traffic flow, and increase crash potential.

~~When on-street parking is to be an element of design, parallel parking should be considered. Under certain circumstances, angle parking is an allowable form of street parking. The type of on-street parking selected should depend on the specific function and width of the street, the adjacent land use, traffic volume, as well as existing and anticipated traffic operations. On-street parking is allowed on facilities with posted speeds of 35 mph or less.~~

~~It can generally be stated that on-street parking decreases through capacity, impedes traffic flow, and increases crash potential. However, where parking is needed, and adequate off-street parking facilities are not available or feasible, on-street parking may be necessary.~~

### C.7.h.1 Parallel Parking Lanes

Minimum parking lane widths for parallel parking are provided in Table 3 – 24 Minimum Parallel Parking Lane Width.

If on-street parking is provided adjacent to a bike lane, a buffer zone should be provided to reduce the potential for a car door opening into the bike lane (door zone). The buffer zone between the bike lane and on-street parking should be at least 3' wide, however 4' is preferred. See Figure 9 – 18 Buffered Bicycle Lane Markings with On-Street Parking for more information.

# DRAFT

**Table 3 – 24 Minimum Parallel Parking Lane Width**

<u>Facility</u>	<u>Posted Speed (mph)</u>	<u>Parallel Parking Lane Width<sup>1</sup> (feet)</u>
<u>Arterial</u>	<u>≤ 35 mph</u>	<u>8<sup>2</sup></u>
<u>Collector</u>	<u>≤ 35 mph</u>	<u>8<sup>2,3</sup></u>
<u>Local</u>	<u>≤ 35 mph</u>	<u>8<sup>2,3</sup></u>

1. Width measured to face of curb.  
 2. A parking lane width of 10 to 12 feet is desirable where delivery trucks need to be accommodated.  
 3. May be reduced to 7 feet minimum in residential areas or with posted speeds 25 mph or less, where only passenger vehicles need to be accommodated.

See **Figure 3 – 15** for example details for the signing and marking of parallel parking spaces. The **MUTCD** provides additional examples of how on-street parking may be marked.

**Figure 3 – 15 Signing and Marking of Parallel Parking Spaces**

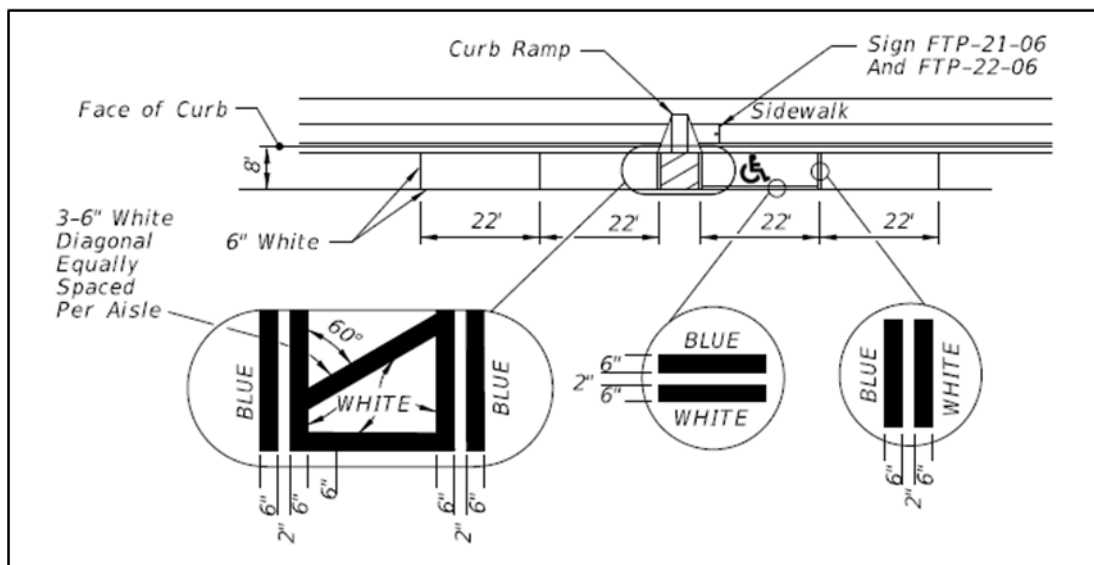

# DRAFT

## C.7.h.2 Angle Parking

Under certain circumstances, angle parking is an allowable form of street parking. Consideration must be given to the specific function and width of the street, the adjacent land use, traffic volume, and posted speed, as well as existing and anticipated traffic operations. Angle parking presents special problems because of the varying lengths of vehicles and the sight distance problems associated with vans and recreational vehicles. The extra length of such vehicles may interfere with the traveled way. When reverse angle parking is proposed for on-street parking, a raised median may be used to discourage front in parking and access from the opposite direction of travel.

Angle parking typically requires a minimum of 17 to 18 feet between the curb face or edge of pavement and traveled way.

See **Figure 3 – 16** *Signing and Marking of 45 degree Forward-In Angle Parking* and **Figure 3 – 17** *Signing and Marking of 45 degree Reverse-In Angle Parking*, for examples of angle parking.

**Figure 3 – 16 Signing and Marking for 45 degree Forward-In Angle Parking**

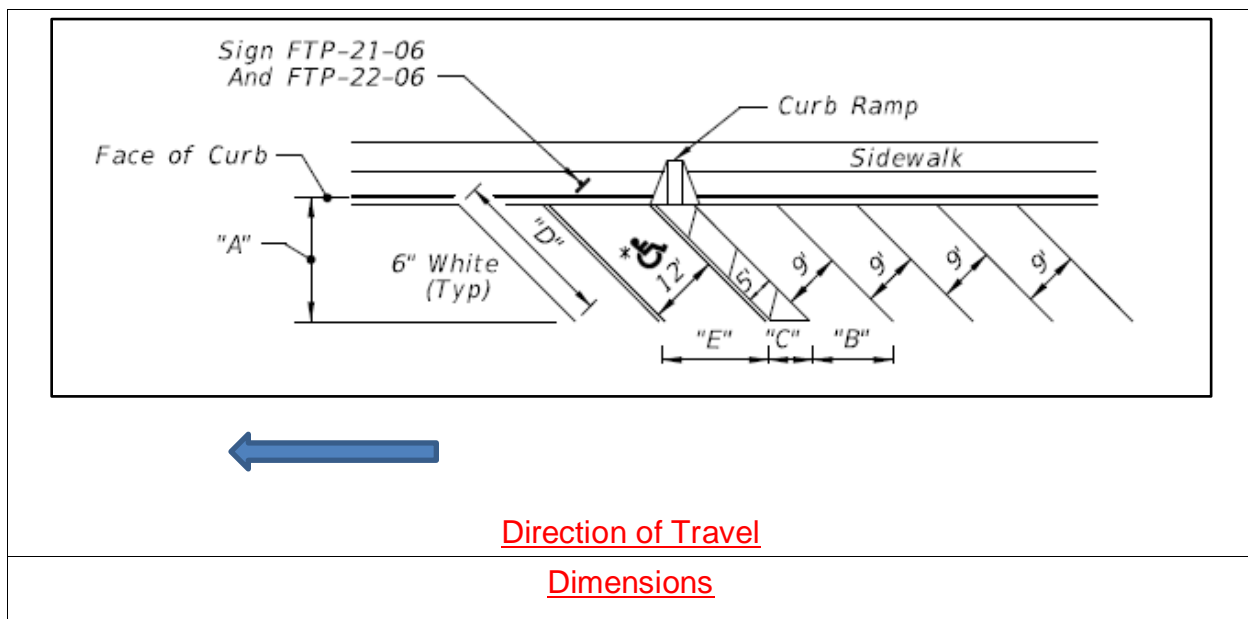



# DRAFT

Topic # 625-000-015  
Manual of Uniform Minimum Standards  
for Design, Construction and Maintenance  
for Streets and Highways

---

~~2023~~2018

<u>"A"</u>	<u>"B"</u>	<u>"C"</u>	<u>"D"</u>	<u>"E"</u>
<u>17' 0"</u>	<u>12' 9"</u>	<u>7' 0"</u>	<u>24' 0"</u>	<u>17' 0"</u>

# DRAFT

**Figure 3 – 17** Signing and Marking for 45 degree Reverse-In Angle Parking

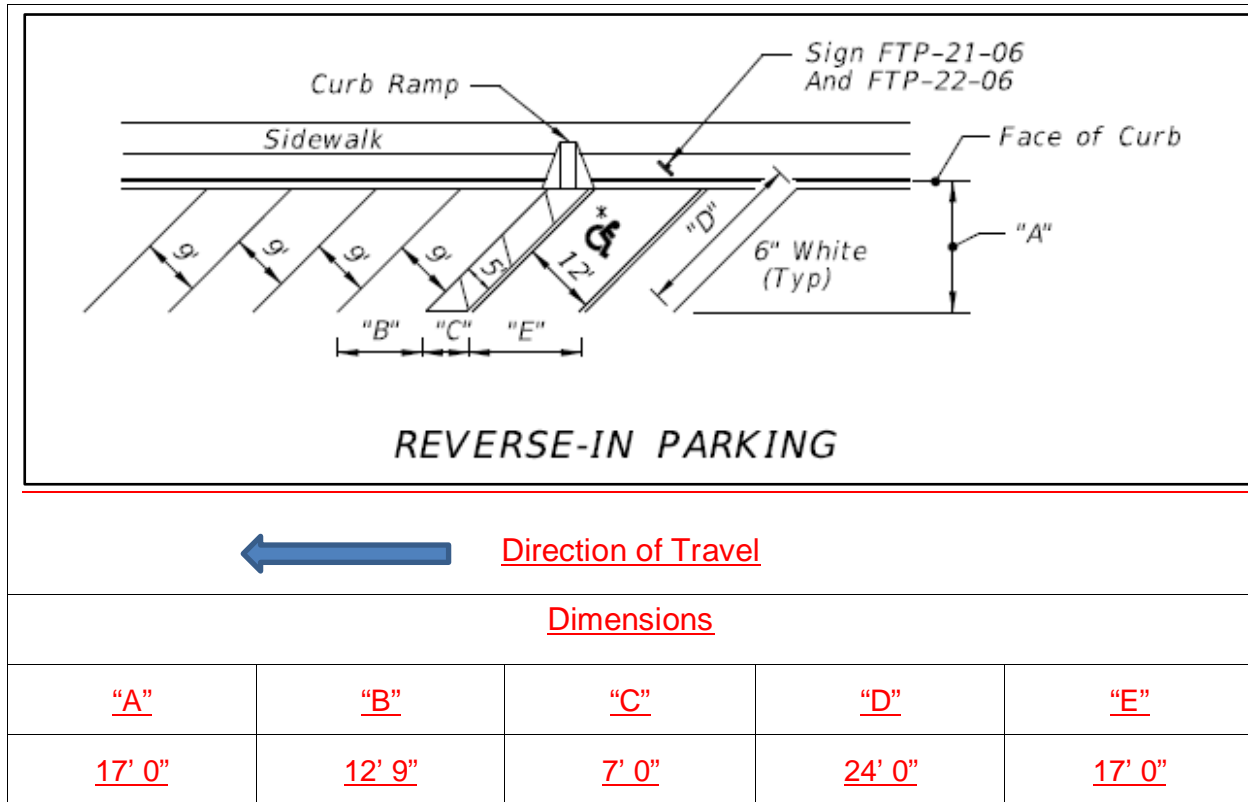

### C.7.h.3 Cross Slope

Cross slopes on parking lanes may be 0.015 to 0.05. Portions of parking lanes that are reserved for parking and access isles for people with disabilities are to have cross slopes not exceeding 2%. See Section C.7.h.4 for further information on accessibility requirements.

The height of the curb, pavement cross slope, utilities, street furniture, and landscaping can all affect the functionality of on-street parking. A bilevel sidewalk can help mitigate the differences in diverse elevations between the roadway, on-street parking, and access to buildings.

### C.7.h.4 ADA Requirements

In addition to the criteria provided in this section, accessible parking

# DRAFT

spaces shall be included with on-street parking in accordance with the requirements of the **2006 Americans with Disabilities Act Standards for Transportation Facilities** as required by 49 C.F.R 37.41 or 37.43 and the **2020 Florida Building Code, Accessibility (7th Edition)** as required by 61G20-4.002. Additionally, the **U.S. Access Board's (Proposed Public Rights-of-Way Accessibility Guidelines, Section R309 On-Street Parking)** provides the latest direction on accessible design requirements that should be followed.

Figure 3 – 16 Signing and Marking for 45 degree Forward-In Angle Parking and Figure 3 – 17 Signing and Marking for 45 degree Reverse-In Angle Parking provide examples of dimensions, signing and marking of on-street parking including accessible parking spaces. The FDOT's **Standard Plans** provide further information on the Universal Symbol of Accessibility (Accessible Parking Pavement Marking) and the required signage designating accessible parking spaces.

### **C.7.h.5 Parking Restrictions**

On-street parking space boundaries shall be established in accordance with the restrictions identified in **F.S. 316.1945**, which restricts parking near driveways, intersections, crosswalks, railroad crossings, fire hydrants and fire stations.

On-street parking shall be located no closer to driveways and intersections than the distances provided in Table 3 – 25 Parking Restrictions for Driveways, Intersections, and Mid-Block Crosswalks. This includes mid-block crossings and roundabout approaches. Midblock crossings on streets with parking should include curb extensions or bulb-outs to improve a driver's and pedestrian's ability to see each other. See Chapter 15 – Traffic Calming for more information.

# DRAFT

**Table 3 – 25 Parking Restrictions for Driveways, Intersections and Mid-Block Crosswalks**

<b><u>Control Type</u></b>	<b><u>Posted Speed (mph)</u></b>	<b><u>A Up Stream (feet)</u></b>	<b><u>B Down Stream (feet)</u></b>	
			<b><u>2- Lane</u></b>	<b><u>4-Lane or More</u></b>
<b><u>Unsignalized</u></b>	<b><u>&lt; 35</u></b>	<b><u>90</u></b>	<b><u>60</u></b>	<b><u>45</u></b>
	<b><u>35</u></b>	<b><u>105</u></b>	<b><u>70</u></b>	<b><u>50</u></b>
<b><u>Signalized and 4-Way Stop Controlled</u></b>	<b><u>&lt; 35</u></b>	<b><u>30</u></b>	<b><u>30</u></b>	<b><u>30</u></b>
	<b><u>35</u></b>	<b><u>50</u></b>	<b><u>50</u></b>	<b><u>50</u></b>

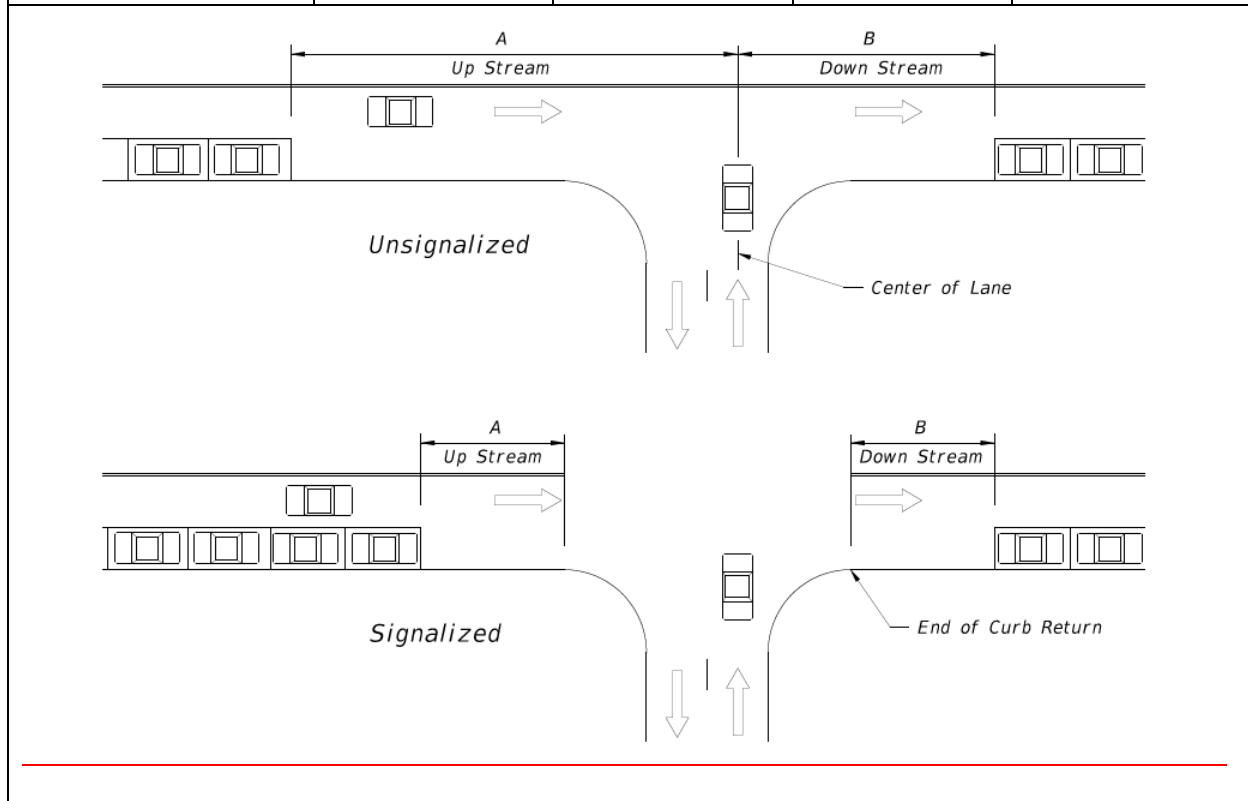

**Notes:**

- 1. For entrances to one-way streets, the downstream restriction (B) may be reduced to 20 feet.**
- 2. Do not place parking within 20 feet of the nearest edge of a marked crosswalk.**

## **C.7.h.6      Signing and Marking**

Signing and marking of on-street parking shall conform to **MUTCD** as well as ADA requirements identified in Section C.7.h.4.

### **C.7.i      Right of Way**

The acquisition of sufficient right of way is necessary in order to provide space for a safe street or highway. The width of the right of way required depends on the design of the roadway, the arrangement of bridges, underpasses and other structures, and the need for cuts or fills. The right of way acquired should be sufficient to:

- Allow development of the full cross section, including adequate medians and roadside clear zones. Determination of the necessary width requires that adequate consideration also be given to the accommodation of utility poles beyond the clear zone.
- Allow the layout of safe intersections, interchanges, and other access points.
- Allow adequate sight distance at all points, particularly on horizontal curves, at an intersection, and other access points.
- Allow, where appropriate, additional buffer zones to improve roadside safety, noise attenuation, and the overall aesthetics of the street or highway.
- Allow adequate space for placement of pedestrian and bicycle facilities, including curb ramps, bus bays, and transit shelters, where applicable.
- Allow for future lane additions, increases in cross section, or other improvement. Frontage roads should also be considered in the ultimate development of many high volume facilities.
- Allow treatment of stormwater runoff.
- Allow for construction of future intersection improvements, such as turn lanes, bicycle and pedestrian facilities or over and underpasses.
- Allow corner cuts for upstream corner crossing drainage systems and placement of poles, boxes, and other visual screens out of the critical sight triangle.
- Allow landscaping and irrigation as required for the project.

The acquisition of wide rights of way is costly, but it may be necessary to allow the construction and future improvement of safe streets and highways. The minimum right of way should be at least 50 feet for all two-lane roads. For pre-existing conditions, when the existing right of way is less than 50 feet, efforts should be made to acquire the necessary right of way.

Local cul-de-sac and dead end streets having an ADT of less than or equal to 400 and a length of 600 feet or less, may utilize a right of way of less than 50 feet, if all elements of the typical section meet the standards included in this Manual.

The right of way for frontage roads may be reduced depending on the typical section requirements and the ability to share right of way with the adjacent street or highway facility.

## **C.7.j Changes in Typical Section**

### **C.7.j.1 General Criteria**

Changes in cross section should be avoided. When changes in widths, slopes, or other elements are necessary, they should be affected in a smooth, gradual fashion.

### **C.7.j.2 Lane Deletions and Additions**

The addition or deletion of traffic or bicycle lanes should be undertaken on tangent sections of roadways. The approach to lane deletions and additions should have ample advance warning and sight distance.

The termination of lanes (including auxiliary lanes) shall meet the general requirements for merging lanes. See Section C.9.c.1 for additional information.

Where additional lanes are intermittently provided on two-lane, two-way highways, median separation should be considered.

### **C.7.j.3 Preferential Lanes**

To increase the efficiency and separation of different vehicle

movements, preferential use lanes, such as bike lanes and bus lanes, should be considered. These lanes are often an enhancement to corridor safety and increase the horizontal clearance to roadside aboveground fixed objects. The [MUTCD, Chapter 3D](#) provides further information on preferential lane markings. See **Chapter 9 – Bicycle Facilities** for information on marking bicycle lanes.

#### **C.7.j.4 Structures**

The pavement, median, and shoulder width, and sidewalks should be carried across structures such as bridges and box culverts. Shoulder widths for multi-lane rural divided highway bridges may be reduced as shown in Table 3 – 20 Minimum Shoulder Widths for Flush Shoulder Rural Highways. The designer should evaluate the economic practicality of utilizing dual versus single bridges for roadway sections incorporating wide medians.

The minimum roadway width for bridges on urban streets with curb and gutter shall be the same as the curb-to-curb width of the approach roadway. Sidewalks on the approaches should be carried across all structures. Curbed sidewalks should not be used adjacent to traffic lanes when design speeds exceed 45 mph. When the bridge rail (barrier wall) is placed between the traffic and sidewalk, it should be offset a minimum distance of 2½ feet from the edge of the travel lane, wide curb lane or bicycle lane. For long (500 feet or greater), and/or high level bridges, it is desirable to provide an offset distance that will accommodate a disabled vehicle. The transition from the bridge to the adjacent roadway section may be made by dropping the curb at the first intersection or well in advance of the traffic barrier, or reducing the curb in front of the barrier to a low sloping curb with a gently sloped traffic face. See **Chapter 17 – Bridges and Other Structures** for additional requirements.

##### **C.7.j.4.(a) Lateral Offset**

Supports for bridges, barriers, or other structures should be placed at or beyond the required shoulder. Where possible, these structures should be located outside of the required clear zone. See **Chapter 4 – Roadside Design** for additional information on lateral offsets for structures.

## C.7.j.4.(b) Vertical Clearance

Vertical clearance should be adequate for the type of expected traffic. Freeways and arterials shall have a vertical clearance of at least 16 feet-6 inches (includes 6 inch allowance for future resurfacing). Other streets and highways should have a clearance of 16 feet unless the provision of a reduced clearance is fully justified by a specific analysis of the situation (14 feet minimum). The minimum vertical clearance for a pedestrian or shared use bridge over a roadway is 17 feet. The minimum vertical clearance for a bridge over a railroad is 23 feet; however additional clearance may be required by the rail owner.

## C.7.j.4.(c) End Treatment

The termini of guardrails, bridge railings, abutments, and other structures should be constructed to protect vehicles and their occupants from serious impact. Requirements for end treatment of structures are given in **Chapter 4 - Roadside Design**.

## C.8 Access Control

All new facilities (and existing when possible) should have some degree of access control since each point of access produces a traffic conflict. The control of access is one of the most effective, efficient, and economical methods for improving the capacity and safety characteristics of streets and highways. The reduction of the frequency of access points and the restriction of turning and crossing maneuvers, which should be primary objectives, is accomplished more effectively by the design of the roadway geometry than by the use of traffic control devices. Design criteria for access points are presented under the general requirements for intersection design.

Additional information on access management can be found in [Rule Chapter 14-97 State Highway System Access Control Classification System, Florida Administrative Code](#). The ~~The Department~~[FDOT's Access Management Guidebook \(2019\) Driveway Information Guide \(2008\)](#) and provides further information on designing roadways and connections to support access management.



## **C.8.a Justification**

The justification for control of access should be based on several factors, including safety, capacity, economics, and aesthetics.

## **C.8.b General Criteria**

### **C.8.b.1 Location of Access Points**

All access locations should have adequate sight distance available for the safe execution of entrance, exit, and crossing maneuvers.

Locations of access points near structures, decision points, or the termination of street or highway lighting should be avoided.

Driveways should not be placed within the influence zone of intersections or other points that would tend to produce traffic conflict.

### **C.8.b.2 Spacing of Access Points**

The spacing of access points should be adequate to prevent conflict or mutual interference of traffic flow.

Separation of entrance and exit ramps should be sufficient to provide adequate distance for required weaving maneuvers.

Adequate spacing between access and decision points is necessary to avoid burdening the driver with the need for rapid decisions or maneuvers.

Frequent median openings should be avoided.

The use of a frontage road or other auxiliary roadways is recommended on arterials and higher classifications where the need for direct driveway or minor road access is frequent.

### **C.8.b.3 Restrictions of Maneuvers**

Where feasible, the number and type of permitted maneuvers

(crossing, turning slowing, etc.) should be restricted.

The restriction of crossing maneuvers may be accomplished by the use of grade separations and continuous raised medians.

The restriction of left turns is achieved most effectively by continuous medians.

Channelization should be considered for the purposes of guiding traffic flow and reducing vehicle conflicts.

#### **C.8.b.4 Auxiliary Lanes**

Deceleration lanes for right turn exits (and left turns, where permitted) should be provided on all high-speed facilities. These turn lanes should not be excessive or continuous since they complicate pedestrian crossings and bicycle/motor vehicle movements.

Storage (or deceleration lanes) to protect turning vehicles should be provided, particularly where turning volumes are significant.

Special consideration should be given to the provisions for deceleration, acceleration, and storage lanes in commercial or industrial areas with significant truck/bus traffic.

#### **C.8.b.5 Grade Separation**

Grade separation interchange design should be considered for junctions of high-volume arterial streets and highways.

Grade separation (or an interchange) should be utilized when the expected traffic volume exceeds the intersection capacity.

Grade separation should be considered to eliminate conflict or long waiting periods at potentially hazardous intersections.

## C.8.b.6 Roundabouts

Roundabouts have proven safety and operational characteristics and should be evaluated as an alternative to conventional intersections whenever practical. Modern roundabouts, when correctly designed, are a proven safety countermeasure to conventional intersections, both stop controlled and signalized. In addition, when constructed in appropriate locations, drivers will experience less delay with modern roundabouts. [NCHRP Report 672 Roundabouts: An Informational Guide](#), is adopted by FHWA and establishes criteria and procedures for the justification, operational and safety analysis of modern roundabouts in the United States. The modern roundabout is characterized by the following:

- A central island of sufficient diameter to accommodate vehicle tracking and to provide sufficient deflection to promote lower speeds
- Entry is by gap acceptance through a yield condition at all legs
- Speeds through the intersection of 20 - 25 mph.
- Single or multilane configurations.

Roundabouts should be considered under the following conditions:

1. New construction
2. Reconstruction
3. Traffic Operations improvements
4. Resurfacing (3R) with Right of Way acquisition
5. Need to reduce frequency and severity of crashes

## C.8.c Control for All Limited Access Highways

Entrances and exits on the right side only are highly desirable for all limited access highways. Acceleration and deceleration lanes are mandatory. Intersections shall be accomplished by grade separation (interchange) and should be restricted to connect with arterials or collector roads.

The control of access on freeways should conform to the requirements given in Table 3 – [264](#) Access Control for All Limited Access Highways.