

---

***Florida Stormwater Erosion and Sedimentation  
Control Inspectors Manual, Tier II***

**Florida Department of Environmental Protection**

**Effective October 2018  
(Incorporated by Reference in Rule 40B-400.091, F.A.C.)**

**Manual for Best Management Practice (BMP)  
Inspectors**

**Contents**

**Chapter 6: Regulations and Statutory Requirements**..... 6

**6.1 Introduction** ..... 6

**6.2 NPDES Stormwater Permitting Regulations and Statutory Requirements** ..... 9

        6.2.1 Construction Activities ..... 9

        6.2.2 Large Construction Activity ..... 9

        6.2.3 CGP Permits ..... 10

**6.3 Key CGP Requirements**..... 12

        6.3.1 Contents of an SWPPP ..... 12

**Chapter 7: The Stormwater Pollution Prevention Plan**..... 13

**7.1 Purpose of the SWPPP**..... 13

        7.1.1 What Must the SWPPP Contain? ..... 14

        7.1.2 When Must You Start Following the SWPPP? ..... 16

        7.1.3 Where to Keep the SWPPP and Other Records, and for How Long? ..... 16

        7.1.4 How Often Must the SWPPP be Updated? ..... 16

        7.1.5 Who Must Sign the SWPPP? ..... 17

**7.2 Submitting an NOT** ..... 17

        7.2.1 Can a CGP be Transferred? ..... 18

        7.2.2 How to Submit an NOT ..... 18

**Chapter 8: BMPs for Stormwater Management – [Gray and Green Infrastructure]**..... 19

**8.1 Introduction** ..... 19

        8.1.1 Nonstructural vs. Structural BMPs..... 19

        8.1.2 BMP Treatment Train – Gray and Green Infrastructure ..... 20

        8.1.3 Online vs. Offline BMPs..... 21

**8.2 Earthwork Specifications**..... 21

**8.3 Stormwater Retention Basin – [Gray and Green Infrastructure]**..... 23

**8.4 Exfiltration Tanks and Trenches – [Green Infrastructure] [LEED Credits]** ..... 26

**8.5 Permeable Surfaces – [Green Infrastructure] [LEED Credits]**..... 36

**8.6 Grid and Modular Pavement – [Green Infrastructure] [LEED Credits]** ..... 38

**8.7 Stormwater Detention Basin – [Gray and Green Infrastructure]** ..... 40

**8.8 Underdrain and Filtration Systems – [Green Infrastructure] [LEED Credits]**..... 44

**8.9 Swales, Bioswales, and Vegetative Swales – [Green Infrastructure] [LEED Credits]**..... 50

**8.10 Stormwater Conveyance Channel – [Gray Infrastructure]**..... 56

**8.11 Paved Flume**..... 60

**8.12 Diversion** ..... 62

<b>8.13 Check Dam</b> .....	<b>66</b>
<b>8.14 Outlet Protection</b> .....	<b>68</b>
<b>8.15 Riprap</b> .....	<b>73</b>
<b>8.16 Grid Confinement System</b> .....	<b>77</b>
<b>8.17 Cellular Concrete Block</b> .....	<b>80</b>
<b>8.18 Maintenance</b> .....	<b>85</b>
8.18.1 General .....	85
8.18.2 Maintaining Retention Systems .....	86
8.18.3 Maintaining Detention Systems .....	90
8.18.4 Maintaining Conveyance Systems .....	92
8.18.5 Maintaining Stormwater Management Structures.....	94
8.18.6 Maintaining Vegetation .....	95
<b>Chapter 9: Inspection and Enforcement</b> .....	<b>96</b>
<b>9.1 Introduction</b> .....	<b>96</b>
<b>9.2 The Role of the Inspector</b> .....	<b>96</b>
9.2.1 Conduct .....	96
9.2.2 Compliance.....	97
9.2.3 Handling Violations.....	98
<b>9.3 Site Inspection</b> .....	<b>98</b>
9.3.1 The Inspection .....	98
9.3.2 Tolerances .....	99
9.3.3 Preparing for an Inspection .....	99
9.3.4 Preconstruction Conference .....	101
9.3.5 Before You Leave the Office .....	102
9.3.6 Inspecting the Site.....	102
9.3.7 Causes of Noncompliance .....	104
9.3.8 Inspection Reports .....	106
<b>9.4 Regulatory Agencies</b> .....	<b>107</b>
<b>Appendices</b> .....	<b>109</b>
<b>Appendix A. Human Relations</b> .....	<b>109</b>
<b>Appendix B. Estimating Quantities</b> .....	<b>114</b>
<b>Appendix C. Sample Checklists</b> .....	<b>115</b>
<b>Appendix D. The Erosion and Sediment Control Plan</b> .....	<b>125</b>
<b>Appendix E. Construction Generic Permit</b> .....	<b>131</b>
<b>Program Evaluation</b> .....	<b>156</b>

**List of Figures**

Figure 6.1. Florida's five water management districts ..... 8

Figure 8.1a. Off-line treatment systems ..... 24

Figure 8.1b. Schematic of flow characteristics associated with infiltration from retention ponds during low and high-water table conditions..... 25

Figure 8.2a. Cross-section of typical infiltration/exfiltration system for parking or roads ..... 27

Figure 8.2b. Sample application of a vegetated area for pretreatment of runoff prior to Exfiltration in Frederick County, Maryland ..... 28

Figure 8.2c. Examples of typical underground percolation systems for retrofitting existing storm sewer systems in Orlando, Florida ..... 32

Figure 8.2d. Detailed schematic of a typical observation well ..... 35

Figure 8.3. Examples of porous pavement drainage systems ..... 37

Figure 8.4. Types of grid and modular pavement ..... 39

Figure 8.5a. Typical detention basin hydrographs ..... 41

Figure 8.5b. Examples of dead storage areas in wet ponds ..... 42

Figure 8.5c. Wet detention system, pond configuration – A ..... 43

Figure 8.5d. Wet detention system, pond configuration – B ..... 43

Figure 8.6a. Cross-section of stormwater discharge structure with "mixed media" bank filter system ..... 45

Figure 8.6b. Illustration of typical "natural soil" bank filtration system with box inlet drop spillway and "V" notched weir (wet retention facility)..... 46

Figure 8.6c. Typical subdivision layout showing online detention pond and outfall ..... 47

Figure 8.6d. Typical subdivision layout showing offline detention pond and outfall ..... 48

Figure 8.6e. Typical cross-section of elevated sand filter for stormwater treatment used in conjunction with dry detention facility ..... 49

Figure 8.7a. Typical swale block cross-section ..... 51

Figure 8.7b. Typical waterway shapes and mathematical expressions for calculating cross-sectional area, top width, and hydraulic radius ..... 53

Figure 8.8a. Typical waterway cross-sections..... 58

Figure 8.8b. Typical stone-lined waterways..... 59

Figure 8.9. Paved flume ..... 61

Figure 8.10. Types of diversions ..... 64

Figure 8.11. Spacing between check dams..... 67

Figure 8.12a. Energy dissipater ..... 69

Figure 8.12b. Energy dissipater ..... 70

Figure 8.12c. Pipe outlet conditions ..... 71

Figure 8.12d. Paved channel outlet..... 72

Figure 8.13a. Rock-lined channel ..... 74

Figure 8.13b. Riprap slope protection..... 75

Figure 8.13c. Toe requirements for bank stabilization ..... 76

Figure 8.14a. Grid confinement system ..... 77  
Figure 8.14b. Vegetative protection..... 78  
Figure 8.14c. Gravity-retaining wall..... 78  
Figure 8.15a. Slope protection ..... 81  
Figure 8.15b. Channel bottom protection ..... 82  
Figure 8.15c. Grout illustration ..... 84  
Figure 8.15d. Revegetation..... 84

**List of Tables**

Table 8.1. Grass establishment alternatives ..... 54  
Table B-1. Control measures, problems to look for, and possible remedies ..... 121

# Chapter 6: Regulations and Statutory Requirements

---

## 6.1 Introduction

## 6.2 NPDES Stormwater Permitting Regulations and Statutory Requirements

### 6.2.1 Construction Activities

### 6.2.2 Large Construction Activity

### 6.2.3 CGP Permits

*Responsibilities of the Operator*

*If Construction Changes to a New Operator – What to Do*

*Obtaining CGP Coverage*

## 6.3 CGP Requirements

### 6.3.1 Contents of an SWPPP

## 6.1 Introduction

To minimize the adverse impacts of runoff, Florida was the first state in the country to require stormwater treatment from all new development with the implementation of the State Stormwater Rule in 1982. This technology-based rule includes a goal (the performance standard) and design criteria for different types of best management practices (BMPs) for stormwater treatment, such as retention or wet detention systems.

Two different types of permits are used in implementing the Stormwater Rule:

- *The **Construction Generic Permit (CGP)** is primarily required for construction activities disturbing over an acre or more that require the inspection and maintenance of best management practices (BMPs) to control erosion and sediment. These types of activities are regulated under the federal National Pollutant Discharge Elimination System (NPDES) Program in Florida. The CGP provides for the temporary control of stormwater impacts using temporary BMPs during the construction phase, when land disturbance activities are most significant. **This manual focuses only on the CGP.***
- *In contrast, the **Environmental Resource Permit (ERP)** addresses the construction of structural stormwater management control systems and impacts associated with the wetlands and surface waters of Florida. These systems are left in place postconstruction and post-CGP, long after a site undergoes final stabilization and construction ceases.*

*The ERP Program benefits Florida by requiring the implementation of effective mitigation measures to minimize stormwater pollution to Florida's lakes and streams and protect wetlands. ERPs integrate stormwater quantity and quality, as well as wetland protection requirements, into a*

single permit. They regulate activities such as dredging and filling in wetlands; the construction of stormwater facilities, stormwater treatment systems, and dams or reservoirs; and other activities affecting state waters.

The applicable water management district or DEP District Office may require an ERP before construction begins. Each water management district has an operating agreement with DEP on which agency will process ERPs for particular projects, based on the type of land use or activity. Detailed requirements for stormwater management, including erosion and sediment control during land disturbance, flood control, and stormwater treatment, are found in the specific ERP regulations applicable in the appropriate water management district. These include specific design criteria for various types of stormwater treatment practices. Additional details about these regulations are available online at [Submitting an ERP](#)<sup>1</sup> or [Florida's Water Permitting Portal](#).<sup>2</sup>

Developers need to identify the water management district (**Figure 6.1**) where their project is located to ensure that all permits and environmental issues are properly addressed in their Stormwater Pollution Prevention Plan (SWPPP). Also, it will be necessary to contact the appropriate water management district office for specific ERP and dewatering permit requirements.

---

<sup>1</sup> <https://floridadep.gov/water/submerged-lands-environmental-resources-coordination/content/submitting-erp>

<sup>2</sup> <http://www.flwaterpermits.com>

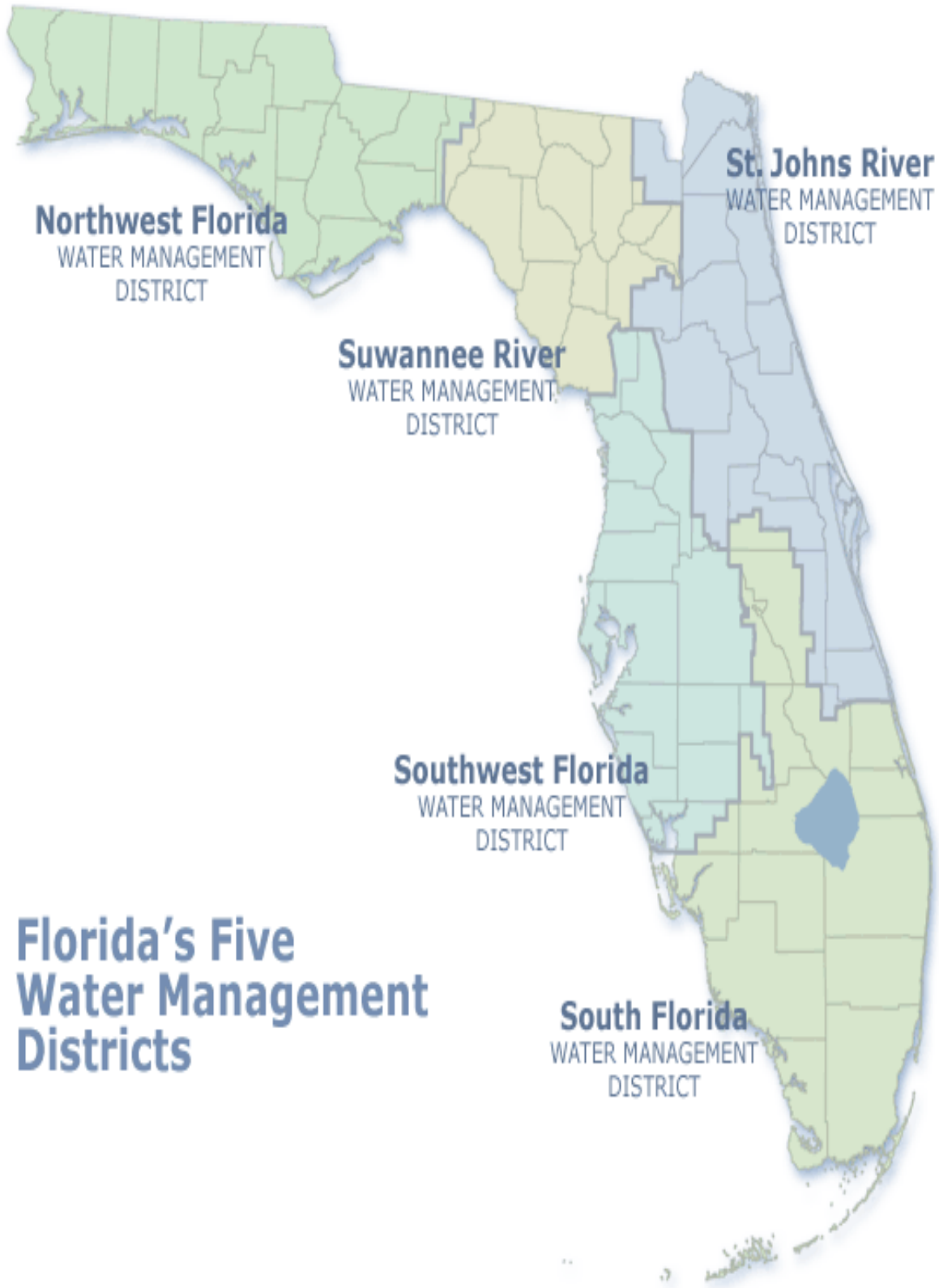

**Figure 6.1. Florida's five water management districts**

Source: <http://www.dep.state.fl.us/water/wetlands/erp/index.htm> or <http://flwaterpermits.com>; <http://www.flwaterpermits.com>



## 6.2 NPDES Stormwater Permitting Regulations and Statutory Requirements

In 2000, the EPA authorized DEP to implement the NPDES Stormwater Program in the state, except for Native American tribal lands. Mandated by the revisions to the federal Clean Water Act adopted by Congress in 1987, the NPDES Program is a national program for addressing many urban stormwater discharges that may adversely impact water quality.

The NPDES Stormwater Program is separate from the state's ERP Program authorized by Part IV, Chapter 373, Florida Statutes (F.S.). The NPDES Program does not establish additional regulations for construction/design features for retention areas, detention ponds, swales, and other stormwater management systems. The construction permit required under DEP's NPDES Program is also separate from any local governmental stormwater discharge permit for construction activity.

The NPDES Stormwater Program regulates some stormwater discharges from the following potential sources:

- *Construction Generic Permit (CGP).*
- *Multi-Sector Generic Permit (MSGP) or No Exposure Exclusion.*
- *Municipal Separate Storm Sewer System (MS4).*

### 6.2.1 Construction Activities

Stormwater runoff from construction activities can have a significant impact on water quality by contributing sediment and other pollutants to waterbodies. The term "construction activity" is defined in Subpart 8.2 of the CGP as "The act or process of developing or improving land, including demolition and renovation activity, which involves the disturbance of soils not limited to, clearing, grading, and excavation."

The NPDES Stormwater Program regulates construction activities that disturb one or more acres of land and discharge stormwater to surface waters of the state or into an MS4. The regulatory definition of an MS4 is "a conveyance or system of conveyances like roads with stormwater systems, municipal streets, catch basins, curbs, gutters, ditches, constructed channels, or storm drains." If a project is less than one acre, but part of a larger common plan of development or sale that will ultimately disturb one or more acres, permit coverage is also required. An MS4 is defined in [Chapter 62-624.200, F.A.C.](#)<sup>3</sup>

### 6.2.2 Large Construction Activity

As defined in Subpart 8.13 of the CGP, this consists of "Construction activity that results in the disturbance of five or more acres of total land area. Large construction activity also includes

---

<sup>3</sup> <http://www.dep.state.fl.us/legal/Rules/shared/62-624.pdf>

the disturbance of less than five acres of total land area that is part of a larger common plan of development or sale that will cumulatively disturb five acres or more."

### **6.2.3 CGP Permits**

#### **Responsibilities of the Operator**

In February 2015, DEP revised the Generic Permit for Stormwater Discharge from Large and Small Construction Activities (CGP) under Subpart 8.20, which defines the term "operator" as follows:

*". . . the person, firm, contractor, public organization, or other legal entity that owns or operates the construction activity and that has authority to control those activities at the project to ensure compliance with the terms and conditions of this permit."*

The operator is ultimately responsible for obtaining permit coverage and implementing appropriate pollution prevention techniques to minimize erosion and sedimentation from stormwater discharges during construction. The operator is the entity with sufficient authority to ensure compliance with the permit requirements. Typically, the operator is the owner, developer, or general contractor. Generally, the architect/engineer should not be listed as the operator unless that individual has operational control over the project and is willing to accept responsibility for compliance with the permit.

#### **If Construction Changes to a New Operator – What to Do**

Coverage under the CGP is not transferable for construction projects where the operator changes. The new operator should obtain permit coverage at least 2 days before assuming control of the project, and the previous operator should file an NPDES Stormwater Notice of Termination (DEP Form 62-621.300[6]) within 14 days of relinquishing control of the project to a new operator. The previous operator must meet the conditions to terminate coverage in accordance with Part VIII of the CGP.

#### **Obtaining CGP Coverage**

To obtain NPDES stormwater permit coverage, a regulated construction operator can go to DEP's [NPDES Stormwater Program website](#), and then to "View our step-by-step guidance on how to apply for a: CGP";<sup>4</sup> or you can use DEP's [Business Portal](#):<sup>5</sup>

1. *Obtain and carefully read the CGP.*
2. *Before submitting the Notice of Intent (NOI) application, you must develop a site-specific SWPPP.*
3. *Applicants now can electronically submit an iNOI after setting up a personal identification number (PIN) and an account to pay any fees.*

---

<sup>4</sup> <https://floridadep.gov/water/stormwater>

<sup>5</sup> <http://www.fldepportal.com/go/>

4. *Complete in its entirety the application or NOI DEP Form 62-621.300(40)(b).*
5. *Submit the NOI with the appropriate processing fee to the NPDES Stormwater Notices Center. Again, all of this can be done through the iNOI process.*
6. *Do not send construction plans or a copy of the SWPPP when applying for permit coverage under the CGP. Again, submit the NOI application and the appropriate fee based on the size of the construction area. Once the project site is permitted, there may be a scheduled compliance inspection from DEP, or a designated representative may review the contents of the SWPPP during the site compliance inspection. Also, DEP or its representative may request at any time that the SWPPP be submitted for review.*
7. *If your project discharges stormwater to an MS4, you must send a copy of the NOI or the acknowledgment letter within seven calendar days of receipt to the operator of the MS4.*

Operators seeking coverage under the CGP must apply for permit coverage at least 2 days before construction begins. Permit coverage under the CGP is effective 2 days (48 hours) after the date of submittal of a complete NOI and appropriate fee. Submittal is interpreted as "postmarked." NOIs should be mailed to the following address:

**Florida Department of Environmental Protection  
NPDES Stormwater Notices Center  
2600 Blair Stone Road, MS# 2510  
Tallahassee, FL 32399-2400**

It is preferable and much quicker for applicants to use the new iNOI electronic process to submit an application and fees [online](#).<sup>6</sup>

The NPDES Stormwater Notices Center will send an acknowledgment letter to the operator after reviewing and processing the complete NOI and fee. The acknowledgment or confirmation letter identifies the permit or project number for the activity and indicates the issuance and expiration date for the CGP. Permit coverage under the CGP is limited to five years. If a construction activity extends beyond a period of five years, the operator is required to reapply for permit coverage.

It is important to post a copy of the NOI, or to post a copy of the acknowledgment letter, at the construction site in a prominent place for public viewing, such as alongside a building permit on a permits board.

---

<sup>6</sup> <http://www.fldepportal.com/go/>.

## 6.3 Key CGP Requirements

The major CGP requirements are as follows (for a complete summary of the regulatory requirements, always refer to the CGP):

- *Develop and implement an SWPPP.*
- *Post a copy of the NOI or acknowledgment letter.*
- *Conduct the inspections every seven calendar days (not work days) and after every half-inch or greater rain event.*
- *Keep all records at the construction site, or at an appropriate alternative location as specified in the NOI.*
- *Maintain a site log notebook or computer file folder containing copies of the NOI, the acknowledgment letter granting coverage, your SWPPP, all your inspection reports and records, and all notifications from DEP concerning your site.*
- *Retain records **three years** from the date that the site has reached final stabilization and the Notice of Termination (NOT) is submitted.*
- *Submit an NOT only when the site has reached 70 % or better of final stabilization.*

### 6.3.1 Contents of an SWPPP

The SWPPP must be developed before an NOI is filed in order to receive CGP coverage and must meet or exceed DEP requirements. Also, beginning on the first day of construction activities, the SWPPP must be available at the location identified in the NOI.

The SWPPP must identify potential sources of pollution that may reasonably be expected to affect the quality of stormwater discharges associated with construction activity. In addition, the plan must describe and ensure the implementation of the BMPs that will be used to reduce the pollutants in stormwater discharges associated with construction activity and ensure compliance with the terms and conditions of the permit. A thorough understanding of the plan is essential for proper implementation and maintenance.

The CGP also requires a certification statement to be signed by the operator. The SWPPP must be developed and implemented for each construction site covered by the CGP and must be prepared in accordance with good engineering practices (see **Chapter 7** for additional details on the SWPPP).

# Chapter 7: The Stormwater Pollution Prevention Plan

---

---

## 7.1 Purpose of an SWPPP

*7.1.1 What Must the SWPPP Contain?*

*7.1.2 When Must You Start Following the SWPPP?*

*7.1.3 Where to Keep the SWPPP and Other Records, and for How Long?*

*7.1.4 How Often Must the SWPPP be Updated?*

*7.1.5 Who Must Sign the SWPPP?*

## 7.2 Submitting an NOI

*7.2.1 Can a CGP be Transferred?*

*7.2.2 How to Submit an NOI*

\* \* \* \* \*

## 7.1 Purpose of the SWPPP

The SWPPP documents how you intend to comply with the requirements of your CGP. The SWPPP must be developed before an NOI is submitted to DEP to use coverage under the CGP. Likewise, the SWPPP must meet DEP requirements found in the CGP, Part 4. See **Appendix E** for a copy of the CGP and specifically Part 4 for the SWPPP requirements. Also, beginning on the first day of construction activities, the SWPPP must be available at the location identified in the NOI.

The SWPPP shall identify potential sources of pollution that may reasonably be expected to affect the quality of the stormwater discharges associated with construction activity. In addition, the plan shall describe and ensure the implementation of BMPs that will be used to reduce the pollutants in stormwater discharges associated with the construction activity and ensure compliance with the terms and conditions of the permit. A thorough understanding of the plan is essential for proper implementation and maintenance.

Always keep in mind that all erosion and sedimentation control BMPs are performance based. If a BMP is not performing well enough to prevent a violation of the CGP on the construction site, then consider replacing the underperforming BMP with one that will control the erosion or sedimentation leaving the construction site. Additionally, each time a BMP is replaced with another, remember to revise the SWPPP to reflect the BMP change within seven days as required by the CGP. Again, all erosion and sedimentation control BMPs are performance based. Always consider layering BMPs to maximize their effectiveness.

The CGP requires a certification statement to be signed by the operator. An SWPPP must be developed and implemented for each construction site covered by the CGP and must be prepared in accordance with good engineering practices and following standard industry practices as found in the *2013 Designer and Reviewer Manual*.

### **7.1.1 What Must the SWPPP Contain?**

The CGP, Part 4.7, Table 4.7.1, lists the items that must be included in your SWPPP. The SWPPP must clearly identify the contractor(s) or subcontractor(s) who will implement each item. Realize these items will be checked if DEP inspects your site for compliance with the CGP and the SWPPP. The SWPPP must be maintained like any other BMP and kept up to date. You have seven calendar days to update the SWPPP as site conditions change and BMPs change accordingly.

The SWPPP must include the following information:

- *Stormwater Team – Identify the stormwater team (by name or position) responsible for implementing the SWPPP, including the qualified inspector. List each individual's responsibilities in developing or implementing the SWPPP.*
- *Contractors and Subcontractors – Identify the contractors and subcontractors who will be carrying out construction activities at the site and identify the areas of the site where they will be working. All listed contractors and subcontractors must sign certifications.*
- *Description of site activities:*
  - Describe the intended sequence and timetable for major activities that will disturb soils.
  - Provide the scheduled start and end date for each major activity, including land clearing, grubbing, grading, cut and fill, dewatering operations, the installation of erosion and sediment controls, the installation of stormwater management systems, paving, the temporary or final stabilization of exposed soil, and the removal of construction equipment and vehicles.
  - Estimate the total area of the site and the total area that is expected to be disturbed by excavation, grading, or other construction activity.
  - Include existing data on soil types and the quality of any existing discharge from the site.
  - For each proposed discharge point, provide the following information:
    - *Latitude and longitude.*
    - *Drainage area.*
- *Estimate the amount of land that will be cleared during the construction activity for each drainage area.*
- *Provide a map/site plan showing all of the following:*
  - Boundaries of the property.

- Entrance/exit points.
  - Locations where construction activities will occur.
  - Locations where dewatering operations will occur.
  - Drainage patterns and approximate slopes and elevations anticipated after major grading activities.
  - Areas of soil disturbance.
  - Areas that will not be disturbed.
  - Location of major structural and nonstructural controls.
  - Location of areas where stabilization practices are expected to occur.
  - Location of surface waters and wetlands.
  - Location where stormwater is proposed to be discharged during construction to a surface water or MS4.
- ***Nonstormwater Discharges*** – List all nonstormwater discharges covered under the permit and the pollution prevention procedures that will be implemented (see the CGP, Part 3.3).
  - ***Dewatering Controls (as applicable)*** – Describe the BMPs that will be used to ensure that discharges of noncontaminated groundwater from dewatering operations do not cause or contribute to violations of state water quality standards.
  - ***BMPs*** – Describe the BMPs that will be implemented for each major activity and the timing of their implementation during the construction process (see the CGP, Part 5).
  - ***Permanent Stormwater Management Controls*** – Describe the stormwater management controls or BMPs (e.g., stormwater detention or retention systems, vegetated swales, or velocity dissipation devices at discharge points) that will be installed during the construction process to control pollutants in stormwater discharges (see the CGP, Part 5.7).
  - ***Inspections*** – Inspections must be carried out at least once every 7 calendar days and within 24 hours of the end of a storm event that is 1/2 inch or greater (even if it rains on the weekend or a holiday) (see the CGP, Part 6).
  - ***Maintenance*** – Describe the maintenance activities and schedules that will be followed to keep the BMPs in good and effective operating condition.
  - ***Signed Certifications*** – As noted above, include all the signed contractor and subcontractor certifications in the SWPPP (see the CGP, Table 4.7.1).

- **Other Activities** – Other activities to be described include dust control, ingress and egress, stockpile locations, sanitary control, BMP stockpiles for hurricane season, spill prevention and clean-up supplies and DEP notification, vector controls, and many other activities carried out over the life of a construction project.

### **7.1.2 When Must You Start Following the SWPPP?**

You must develop the SWPPP before you submit your NOI. You must start following your SWPPP when you receive coverage under this permit. If the SWPPP requires perimeter controls, they must be installed before construction activities commence.

### **7.1.3 Where to Keep the SWPPP and Other Records, and for How Long?**

- *Keep all records at the construction site, or at an appropriate alternative location as specified in the NOI.*
- *You must maintain a site log notebook or computer file folder that contains copies of the NOI, the acknowledgment letter granting coverage, your SWPPP, all your inspection reports and records, and all notifications from DEP concerning your site.*
- *Keep all records for three years from the date that the site has reached final stabilization and the Notice of Termination (NOT) is submitted.*

### **7.1.4 How Often Must the SWPPP be Updated?**

You must keep your SWPPP current. You must sign and date any changes to the SWPPP and keep them as attachments to the original plan. Whenever any of the following events occur, you have seven calendar days to update your SWPPP:

- *There is a change in design, construction, operation, or maintenance that has a significant effect on the discharge from your project.*
- *There is a new discharge point or outfall.*
- *There is a change in the location of a discharge point or outfall.*
- *An inspection (see the CGP, Part 6) reveals that BMPs are ineffective at eliminating or minimizing pollutants in the stormwater discharged from the site.*
- *A new operator, contractor, or subcontractor is implementing any portion of the SWPPP. If a new operator is taking over a portion of the project site, you must update your SWPPP to note the area that is no longer covered by your*



*CGP and inform the new operator in writing that you are no longer covering construction activities in that area. This documentation must be kept as part of your SWPPP (see the CGP, Part 1.4).*

- *A release containing a hazardous substance in an amount equal to or greater than a reportable quantity occurs during a 24-hour period (see the CGP, Part 9.2, for important information about releases of hazardous substances in excess of reportable quantities).*

It is very important to maintain your SWPPP as one of the BMPs. Do not develop a plan using a "cookie cutter" or "one plan fits all" approach. Each construction site is unique and individual, with its own soil characteristics, topography, drainage patterns, and unforeseen problems specific to that site. Please take time to develop and maintain this important part of your CGP.

### **7.1.5 Who Must Sign the SWPPP?**

All contractors and subcontractors identified in the SWPPP must sign a copy of the certification statement before conducting any construction activities at the site. The certifications must have the name and title of the person signing the certification; the name, address, and telephone number of the contracting firm; and the signature date. The certification statement reads as follows:

"I certify under penalty of law that I understand, and shall comply with, the terms and conditions of the State of Florida Generic Permit for Stormwater Discharge from Large and Small Construction Activities and this Stormwater Pollution Prevention Plan."

## **7.2 Submitting an NOT**

Within 14 calendar days after your site has achieved final stabilization and all discharges authorized by this permit are eliminated or are authorized under a separate NPDES permit, you must submit a completed NOT form. Additionally, the following items must be completed before submitting a NOT, according to the CGP, Part 7:

- *All dewatering discharges authorized by this permit have ceased.*
- *All construction activity discharges authorized by this permit have ceased.*
- *The elimination of stormwater discharges associated with construction activity means that all disturbed soils at the site have been finally stabilized, that temporary erosion and sediment control measures have been removed or will be removed at an appropriate time, and that all stormwater discharges associated with construction activity from the site that are authorized by the CGP have been eliminated.*

### **7.2.1 Can a CGP be Transferred?**

Coverage under the CGP is not transferable. The new owner/operator will need to complete an SWPPP and submit a new NOI and processing fee. You will need to end the current permit coverage by submitting an NOT within 14 calendar days of relinquishing control of the project to a new owner/operator. It is the responsibility of the new owner/operator to obtain permit coverage before the NOT is submitted.

### **7.2.2 How to Submit an NOT**

You can submit the form electronically:

- *The NOT can be filed online at DEP's [Business Portal](#).*<sup>7</sup>
- *Alternatively, you can submit the NOT by email to the Stormwater Notices Center by downloading the NOT at DEP's [NPDES Permits and Forms website](#).*<sup>8</sup>

For additional assistance, contact the Stormwater Notices Center at: (866) 336-6312 (toll-free).

---

<sup>7</sup> <http://www.fldepportal.com/go/>

<sup>8</sup> <https://floridadep.gov/water/stormwater/content/npdes-permits-and-forms>

# Chapter 8: BMPs for Stormwater Management – [Gray and Green Infrastructure]

---

- 8.1 Introduction
  - 8.1.1 *Nonstructural vs. Structural BMPs*
  - 8.1.2 *BMP Treatment Train – Gray and Green Infrastructure*
  - 8.1.3 *Online vs. Offline BMPs*
- 8.2 Earthwork Specifications
- 8.3 Stormwater Retention Basin [Gray and Green Infrastructure]
- 8.4 Exfiltration Tanks and Trenches – [Green Infrastructure] [LEED Credits]<sup>9</sup>
- 8.5 Permeable Surfaces – [Green Infrastructure] [LEED Credits]
- 8.6 Grid and Modular Pavement – [Green Infrastructure] [LEED Credits]
- 8.7 Stormwater Detention Basin [Gray and Green Infrastructure]
- 8.8 Underdrain and Filtration Systems – [Green Infrastructure] [LEED Credits]
- 8.9 Swales, Bioswales, and Vegetative Swales – [Green Infrastructure] [LEED Credits]
- 8.10 Stormwater Conveyance Channel – [Gray Infrastructure]
- 8.11 Paved Flume
- 8.12 Diversion
- 8.13 Check Dam
- 8.14 Outlet Protection
- 8.15 Riprap
- 8.16 Grid Confinement System
- 8.17 Cellular Concrete Block
- 8.18 Maintenance
  - 8.18.1 *General*
  - 8.18.2 *Maintaining Retention Systems*
  - 8.18.3 *Maintaining Detention Systems*
  - 8.18.4 *Maintaining Conveyance Systems*
  - 8.18.5 *Maintaining Stormwater Management Structures*
  - 8.18.6 *Maintaining Vegetation*

\*\*\*\*\*

## 8.1 Introduction

### 8.1.1 *Nonstructural vs. Structural BMPs*

The effective management of stormwater depends on the proper use of specific BMPs. These are grouped into two broad categories, as follows:

- *Nonstructural controls are the first line of defense. They improve stormwater quality by reducing the generation and accumulation of potential stormwater*

---

<sup>9</sup> Leadership in Energy and Environmental Design

*pollutants at or near their sources. Therefore, they are frequently referred to as source controls. Nonstructural controls include practices such as planning and management, wetlands and floodplain protection, public education, proper fertilizer and pesticide application control, solid waste collection and disposal, street cleaning, and "good housekeeping" techniques on construction sites. They are prevention oriented, very cost-effective, and aesthetically acceptable to the public and other inspecting agencies.*

- *In contrast, **structural controls** are used to control stormwater volume and peak discharge rate, and to reduce the magnitude of pollutants in discharge waters through physical containment or flow restrictions designed to allow settling, filtration, percolation, and chemical treatment, or provide biological uptake of nutrients. These practices typically are land intensive, require proper long-term maintenance, and can be costly, especially in already urbanized areas.*

### **8.1.2 BMP Treatment Train – Gray and Green Infrastructure**

A stormwater management system is similar to a BMP treatment train, in which the individual BMPs are like "railroad cars." Generally, the more BMPs that are incorporated into the system, the better the performance of the treatment train. Although the different BMPs in this chapter are discussed individually, they often work together as part of a total system.

Many BMPs are highly susceptible to clogging, especially those using filtration. Treatment swales, sediment forebays, and stilling basins are used to intercept sediments before they reach filtration BMPs.

Today, "Old-World" BMPs, referred to as "gray infrastructure," are used along with "New-World" BMP technologies, or "green infrastructure." Green infrastructure makes sediment removal easier and less costly, while at the same time removing nutrients such as nitrogen and phosphorus. These combined approaches and technologies are used to infiltrate, evapotranspire, capture, and reuse stormwater to maintain and restore the natural hydrologic cycle.

Gray versus green is no longer an issue. Green infrastructure should and must be very much a part of Florida's stormwater management treatment train by reducing nutrients and restoring the many impaired waterbodies in the state. Both gray and green infrastructure are designed to process stormwater runoff and require regular maintenance but differ in how they are constructed and operated. However, in most cases the two systems work together to effectively manage, treat, and conserve the water that Florida needs now and will need in the future.

### **8.1.3 Online vs. Offline BMPs**

Online BMPs temporarily store runoff before they discharge to surface waters. These systems capture all of the runoff from a design storm. They primarily provide flood control benefits, with water quality benefits secondary. However, some online BMPs, such as wet detention systems, can do an excellent job of achieving both objectives.

Offline BMPs divert the first flush of polluted stormwater (often called "treatment volume") and isolate it from the remaining stormwater, which is managed for flood control. Offline retention is the most effective water quality protection BMP, since the diverted first flush is not discharged to surface waters. Stormwater is removed by infiltration, evaporation, and evapotranspiration.

## **8.2 Earthwork Specifications**

### **General Introduction**

This section introduces general best practices associated with the construction of stormwater systems. Additional information associated with best practices is noted in other chapters; i.e., stripping/topsoiling.

### **Definition**

Specifications for earthworks maximize the use of the desirable physical properties of soil and take measures to compensate for weaknesses. This chapter focuses on the practices associated with the construction of stormwater BMPs. For additional information please refer to state and local engineering specifications, and the 2013 *Florida Designer and Reviewer Manual*, as referenced in the CGP.



### **Purpose**

To ensure that inadequate earthwork does not cause the premature failure of constructed improvements.

### **Applications**

This practice applies on all construction sites and where the maintenance of systems is necessary.

### **Construction Specifications**

#### ***Subgrade Preparation***

Proper subgrade preparation involves the clearing and grubbing of land. Except for muck soils, the subgrade should be free of organic debris, demolition debris, and large stones and rocks. If no fill is required, the ground should then be smoothed and compacted. If the area requires fill, the

surface should be scarified or roughened to facilitate proper bonding between the native soil and the fill.

### ***Filling, Backfilling, and Compaction***

All fill material must be properly compacted. Large fill areas, such as embankments, dams, and building pads, can be mechanically compacted with heavy equipment in 6- to 8- inch (15 to 20 cm) lifts of compacted soil. Smaller above-ground fills, such as berms, can be compacted with heavy and medium equipment, or with hand tampers. Backfilling around pipes and manholes is the most sensitive operation, particularly around the bottom half of a pipe. Here fill should be placed in 2- to 4-inch (5 to 10 cm) lifts, and great care must be exercised to avoid damage to fiberglass composite or concrete stormwater pipelines. Small rollers or tampers are commonly used in trenches for pipeline installation, and around inlets and outlets as well to avoid premature failure. Local engineering standards may be more stringent or vary from those described above. Proper compaction testing is required as well.

### ***Surcharge Area***

Fill can be compacted using time and/or water. Where time is not a pressing factor, fill can simply be dumped in place and allowed to settle for several months. The primary force causing settlement is rain. The process can be shortened to several days by constant inundation with a sprinkler. Homebuilders commonly use this technique for compacting fill inside a stem-wall foundation; it can also be used to backfill under pipes. These techniques work best in very sandy soils. Regardless of the method used to achieve compaction, a compaction test should be performed before permanent structures are constructed on top of fill material.

## 8.3 Stormwater Retention Basin – [Gray and Green Infrastructure]

### Definition

A surface area used to store runoff for a selected design storm or specified treatment volume. Stormwater is retained onsite, with the storage volume recovered when the runoff percolates into the soil and through evapotranspiration, which is part of the hydrologic cycle, and using gray and green infrastructure.



### Purposes

To reduce stormwater volume, peak discharge rate, and pollutants, and to recharge groundwater and baseflow (see **Figure 8.1a**).

### Applications

The applicability of this practice primarily depends on the ability of soils to percolate runoff and on the availability of adequate land for a retention area or for modifications of an existing system (see **Figure 8.1b**). Geologic, topographic, and soil conditions must be considered in determining site suitability.

Besides soil infiltration rates, the single most significant limiting factor in many cases is the availability of enough land to provide the necessary storage volume. This is particularly true in densely urbanized areas, where land is scarce and property values are high.

The soil and water table conditions must also be such that the system can, within a maximum of 72 hours following a stormwater event, provide for a new volume of storage through percolation and/or evapotranspiration. When retention systems are vegetated as recommended, the runoff needs to percolate within 24 to 36 hours to ensure the viability of the vegetation. Retention systems do not release stored waters for surface discharge.

### Construction Specifications

Initial basin excavation should be carried to within 1 foot (30 cm) of the final elevation of the basin floor. Interior side slopes should be sodded immediately to prevent erosion and the introduction of additional sediments. Final excavation should be deferred until all contributing areas of the watershed are stabilized. Light equipment should be used to remove accumulated sediments and achieve final grade without compacting the basin floor. After final grading, the basin floor should be scarified with rotary tillers or disc harrows to promote infiltration and grass establishment.

Structural elements, such as embankments, inlets, flumes, and emergency spillways, shall be designed by a Florida registered professional engineer. These elements shall be constructed in

accordance with **EARTHWORK SPECIFICATIONS** (in this chapter) and other acceptable engineering standards.

Do not allow sediment-laden runoff to enter a finished basin. Do not overexcavate to provide additional sediment capacity, unless the intent is to remove all sediments and backfill with a more pervious soil type.

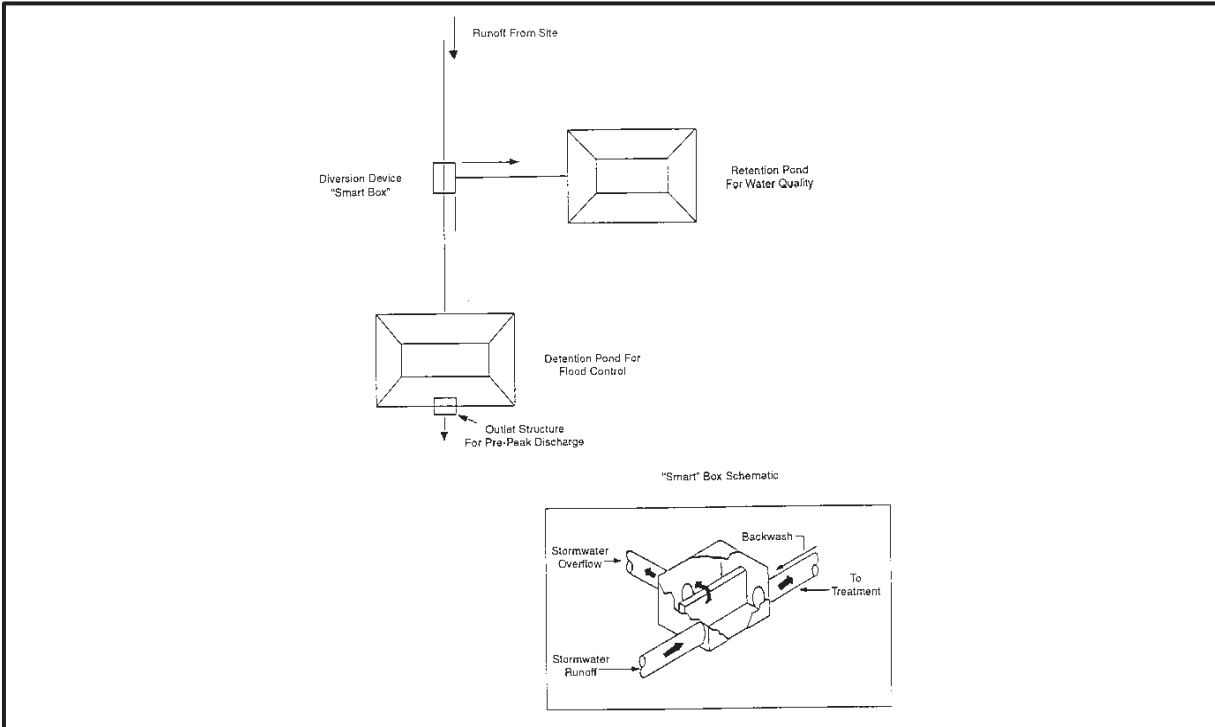

**Figure 8.1a. Off-line treatment systems**

Source: NRCS



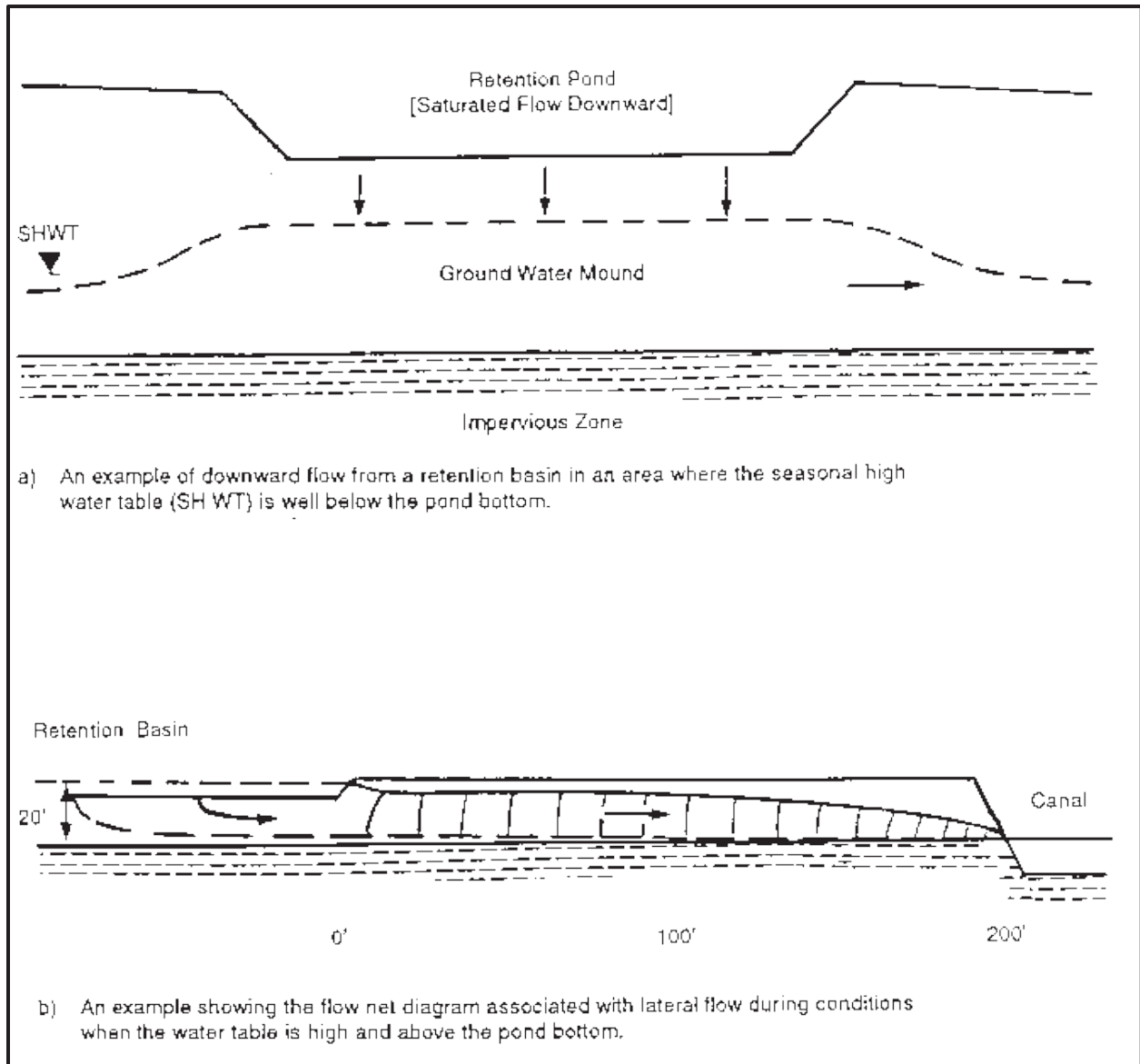

**Figure 8.1b. Schematic of flow characteristics associated with infiltration from retention ponds during low and high-water table conditions**

Source: Hannon 1980

## 8.4 Exfiltration Tanks and Trenches – [Green Infrastructure] [LEED Credits]

### Definition

This consists of the onsite retention of stormwater accomplished below the ground. The subsurface retention BMP most commonly used in Florida is an exfiltration trench, which is an excavated trench backfilled with coarse graded aggregate.

Stormwater runoff is collected for temporary storage and infiltration.



These facilities often include exfiltration tanks and perforated pipe. Water is exfiltrated from the tanks or pipes and infiltrates the trench walls and, to some extent, the trench bottom for disposal and treatment. The addition of the pipe increases the amount of storage available in the system and promotes infiltration by making the delivery of the runoff waters more effective and evenly distributed over the length of the facility.

Exfiltration tanks and trenches should be designed as offline systems that include a weir overflow structure or a diversion, sometimes called a "smart box." The device is installed at the point of inflow to the trench system. Its purpose is to route the runoff to be treated into the perforated pipe and trench for percolation into the surrounding soil. Excess water from larger storms is bypassed away from the trench (see **Figure 8.2a**).

### Purposes

1. *To retain the "first flush" of stormwater runoff to promote water quality improvement.*
2. *To reduce the runoff volume and peak discharge rate from a site, thus helping to reduce downstream flooding and channel degradation.*
3. *To filter contaminants from runoff before they reach receiving waters and to promote the recharge of groundwater supplies as is a part of a green infrastructure system.*

### Applications

This practice should be used where the subsoil is sufficiently permeable to provide a reasonable rate of infiltration, and where the water table is sufficiently lower than the design depth of the facility. It is normally used where space is limited and land is expensive. Exfiltration trenches are frequently used to dispose of runoff from roof drains, parking lots, tennis courts, and roadways. They are not recommended where runoff water contains high concentrations of suspended

materials, unless a presettling sediment trap or vegetated filter strip is provided to prevent premature clogging of the geotextile filter fabric (see **Figure 8.2b**). Likewise, grease and oil traps are also highly recommended prior to discharge to these systems. These precautions are primarily for maintenance reasons, since exfiltration systems are very susceptible to clogging and sediment buildup, which reduce their hydraulic efficiency and storage capacity to unacceptable levels.

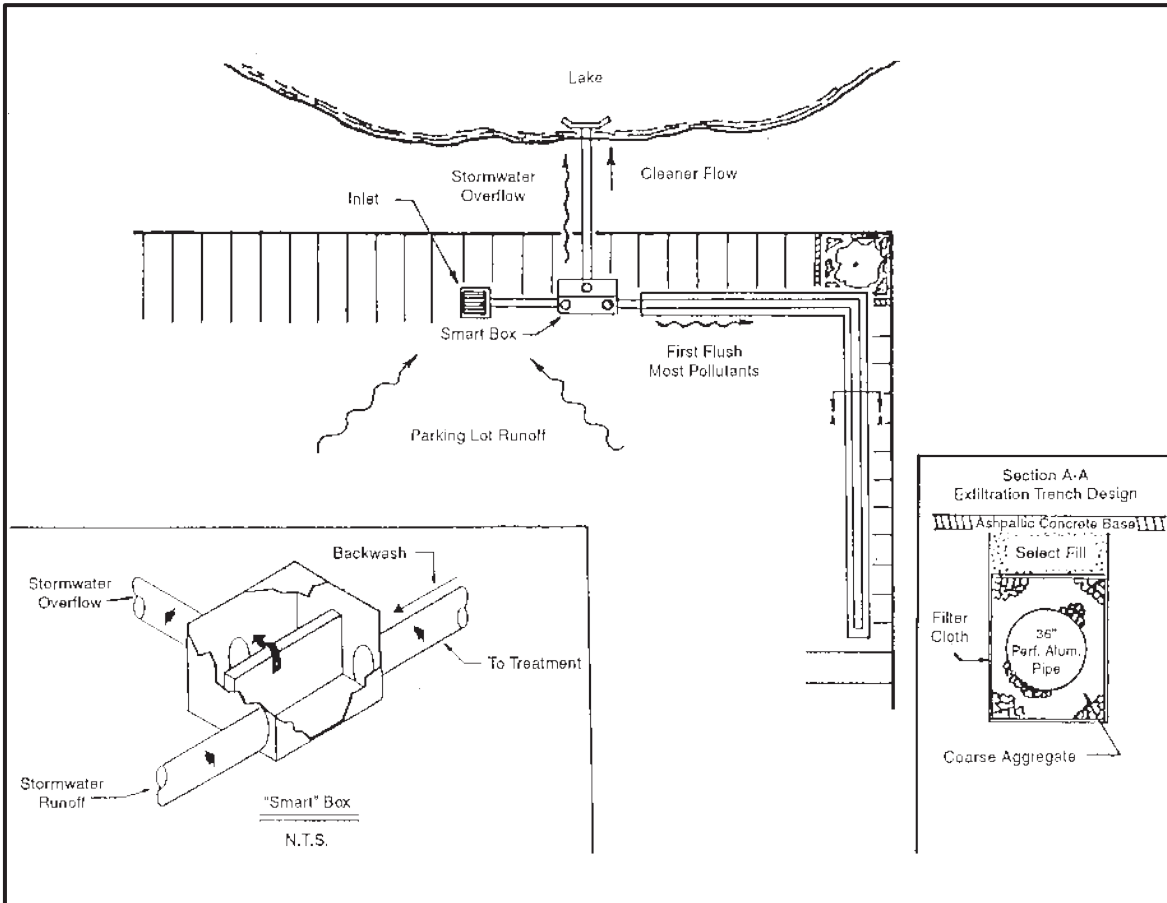

**Figure 8.2a. Cross-section of typical infiltration/exfiltration system for parking or roads**

Source: Dyer, Riddle, Mills and Precourt, Inc., Engineers/Surveyors

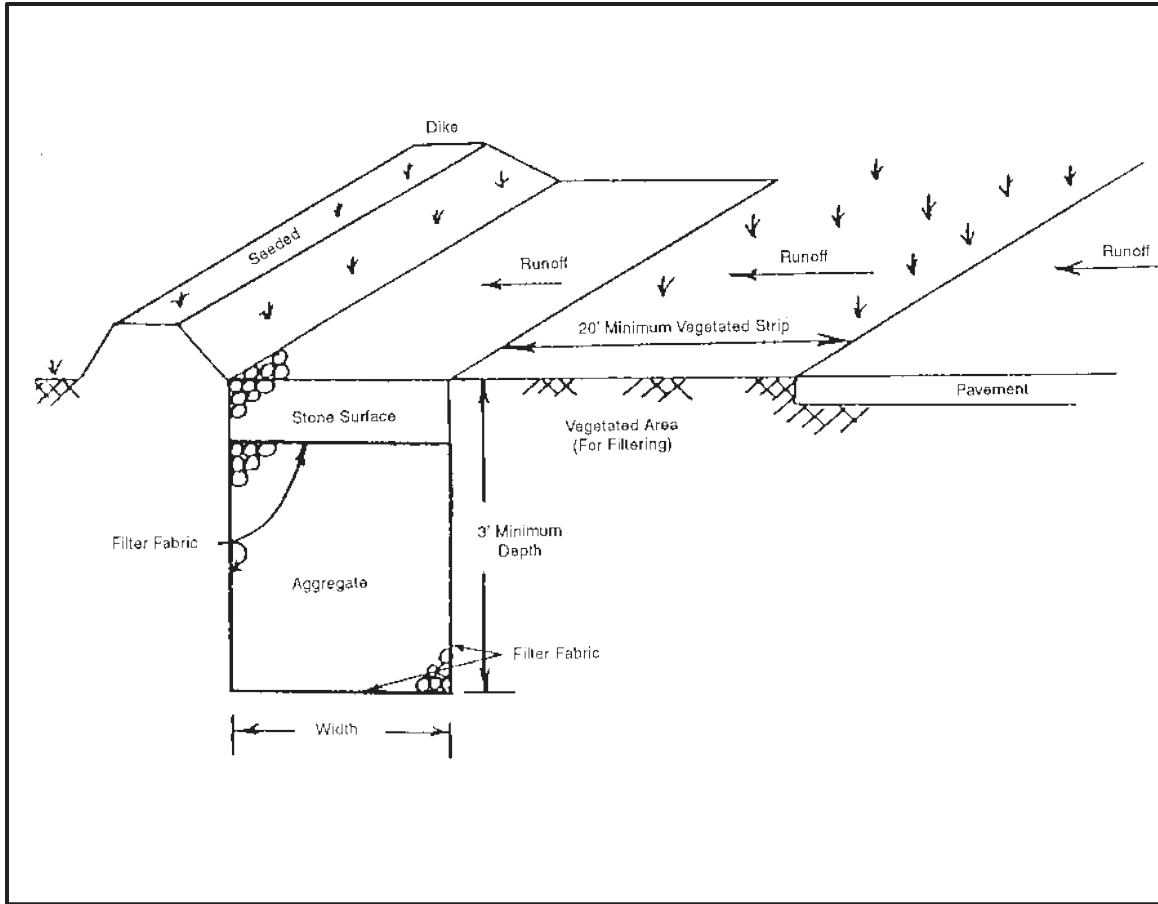

**Figure 8.2b. Sample application of a vegetated area for pretreatment of runoff prior to Exfiltration in Frederick County, Maryland**

Source: NRCS

## **Types of Infiltration Trenches**

Trench construction criteria for three different soil and geologic conditions are as follows:

### **1. Trenches in Rock**

Exfiltration facilities cut into permeable rock are often used in the Miami vicinity. These trenches are the least expensive infiltration system to construct; however, the following conditions must be met:

- 1. The rock must be able to support a specified wheel load on a covering concrete slab or other suitable cover.*
- 2. The rock must be amenable to excavation without blasting.*

The inlet to the system can be placed directly over the slab cover, with discharge directly into the trench. A more acceptable method is to set the inlet and catch basin adjacent to the trench and

pipe the inflow to the trench. This technique lessens the introduction of debris into the system. Manhole access must be provided to facilitate cleaning and inspection.

## **2. Trenches in Stable Soil**

In this type of trench, perforated or slotted pipe is normally used as the conduit. Coarse aggregate between the pipe and trench wall prevents sidewall collapse and distributes collected water to the trench walls. Whether the pipe is included or not, the trench is usually 4 to 5 feet (1.2 to 1.5 m) wide and deep enough to reach a permeable soil layer.

Coarse aggregate or other free-draining material is generally placed in the bottom of the trench and brought up to a specified pipe flowline grade, generally a minimum of 2 feet (60 cm). Perforated or slotted pipe is then placed in the trench, which is backfilled with coarse aggregate to the design storage elevation. A typical Dade County installation includes a 6-inch (15 cm) thickness of finer-textured filter material or pea rock placed over the aggregate backfill. The trench is normally covered with a geotextile to prevent the sand or fill used for cover from piping and possible surface subsidence.

These trench cross-sections are typical of most installations in extreme southern Florida. The configuration is applicable in other areas where the soil or substrate is stable and provides sufficient infiltration capacity. Even where infiltration rates are marginal, the system could supplement the drainage requirements of a positive outfall system by storing and infiltrating a portion of the stormwater into the soil, thus reducing the downstream requirements of the positive system.

## **3. Trenches in Cohesionless Soil or Sand**

Although trenches in cohesionless soil require a different type of construction, the design, final shape, and size are the same as for a trench in stable soil. However, side slopes of 1.5:1 or 2:1 may be required if the walls are not shored during construction. Filter cloth must be used along the periphery of the trench to prevent soil fines from migrating into the coarse aggregate backfill.

In a trench system where tanks or perforated pipe are used, a nonperforated section of 6 to 8 feet (1.8 to 2.4 m) in length is used to connect the trench to the catch basin or inlet. This procedure eliminates piping near structures and subsidence around the inlet. A concrete slab is generally placed around the catch basin or inlet.

In the design of a trench system, any one of the above types, or a combination, may be used. A positive overflow pipe or bypass is also recommended to allow for large storm events.

## **Construction Specifications**

### ***Safety***

Trench construction techniques vary with local site conditions. Strict adherence to the U.S. Occupational Safety and Health Administration (OSHA) Trench Safety Code, and/or other local regulations relative to acceptable construction practice, should be observed. Depending on the length and width of the trench, a backhoe, wheel, or laddertype trencher may be used for excavation. Excavated material should be stored at least 10 feet (3 m) from the trench to avoid backsliding and cave-ins, a trench box is recommended when loose soils or water are in the trench, and a ladder should be available within 25 feet for escape.

### ***General Construction Recommendations***

Proper construction and routine maintenance are extremely important for successful trench applications. A substantial number of trenches have failed shortly after being built, primarily because of poor construction practices or inadequate field testing, or because sediment was not filtered or trapped before entering the trench. The following construction and erosion control procedures should minimize the risk of premature clogging:

- 1. Before the entire development site is graded, the area planned for the trench should be roped off to prevent heavy equipment from compacting the underlying soils.*
- 2. Diversion berms should be placed around the perimeter of the trench during all phases of construction. Sediment and erosion control plans for the site should be oriented to keep sediment and runoff completely away from the trench area. Otherwise, the actual construction of the trench should not begin until after the site is completely stabilized.*
- 3. The trench should be excavated using a backhoe or trencher equipped with tracks or oversized tires. Normal rubber tires should be avoided, since they compact the subsoil and may reduce infiltration capability. For the same reason, the use of bulldozers or front-end loaders should be avoided.*
- 4. Sediment control is critical, and thus it is important that sediment and erosion controls be inspected following each storm to make sure they still work. If a vegetated buffer strip is planned for the pretreatment of runoff entering the facility, grass should be established immediately, preferably by sodding. When hydroseeding is used, reinforced silt fences must be placed between the buffer and trench to prevent sediment entry before the buffer becomes fully established.*

### ***Perforated or Slotted Pipe***

When perforated pipe is used for conveyance and distribution, a liberal number of holes should be provided to ensure free and rapid flow in and out of the walls of the pipe. Large-diameter pipe adds to total storage volume in the trench. The use of a pipe in the trench system also allows for ease of maintenance. The pipe serves as a catchment for sediment without reducing overall efficiency.

Pipes manufactured of plastic, steel, aluminum, concrete, or other materials are available for this application. Perforated metal pipes usually have 3/8-inch (9 mm) diameter perforations uniformly spaced around the full periphery of the pipe. Specifications stipulate not less than 30 perforations per square foot (323 perforations/m<sup>2</sup>) of pipe surface. Other perforations not less than 5/16 inch (8 mm) in diameter or slots are permitted if they provide a total opening area of not less than 3.31 square inches per square foot (230 cm<sup>2</sup>/m<sup>2</sup>) of pipe surface.

FDOT and the industry have developed tentative specifications for slotted concrete pipe with cast slots, based on field performance and cooperative testing. Concrete pipe with 3/8 inch (9 mm) wide slots is usually specified. The slots should be circumferential in direction, approximately 3/8 inch (9 mm) wide and not less than 4 inches (10 cm) long at the inside of the pipe. Four rows of slots are generally specified for pipe 30 inches (75 cm) in diameter or less. Six rows are specified for pipe 36 inches (90 cm) in diameter and larger.

### ***Pipe Backfill***

Coarse aggregate backfill material supports the sides and top of an infiltration trench following construction. It also provides good bedding for distribution and overflow pipes. Aggregates for this purpose must be sound and must comply with FDOT-established specifications for durability. The material must provide sufficient void space to allow for the storage of the required volume of runoff. The designer should also allow for the accumulation of the normally encountered fine sands, silts, silty clays, and other material in stormwater that will pass through the perforations or slots in the pipe conduit into the backfill during the expected life of the facility.

**Clean**, washed stone aggregate should be placed in the excavated trench in lifts, **lightly** compacted to form the base. Unwashed stone has enough associated sediment to pose a clear risk of clogging at the soil/filter cloth interface. Granite, washed pea gravel, or river rock is usually acceptable. Where possible, the use of crushed limestone aggregate should be avoided unless the limestone is washed, contains little or no phosphorus, and is of the hard variety.

### ***Pea Rock or Gravel***

This material is often placed in a 6-inch (15 cm) layer over the top of the aggregate for the pipe backfill, as illustrated in **Figure 8.2c**. This layer serves as a granular filter below the filter fabric. The gradation for this layer should consist of 100 % material passing a 1-inch (25 mm) sieve, with not more than 5 % passing a No. 4 sieve.

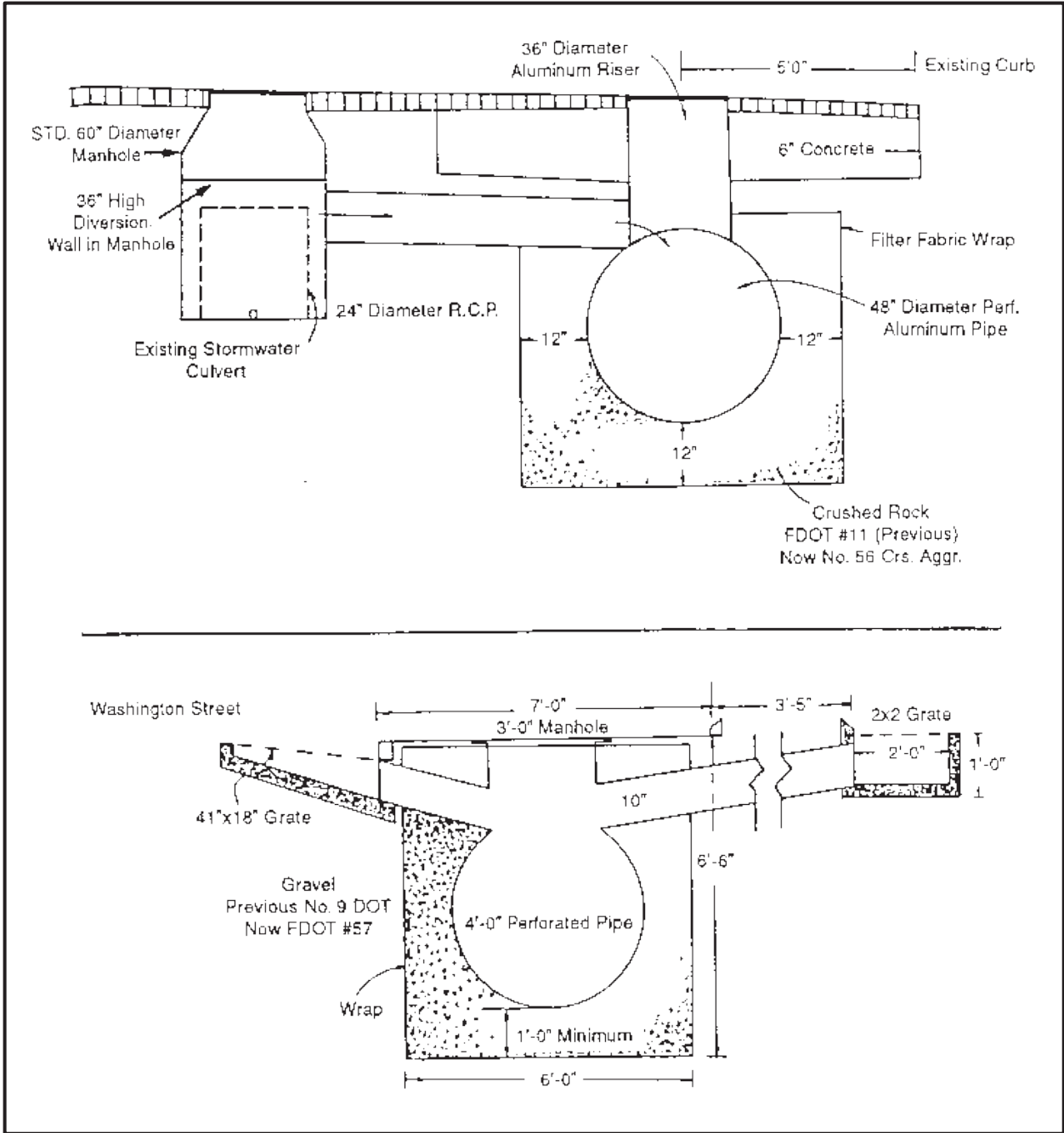

**Figure 8.2c. Examples of typical underground percolation systems for retrofitting existing storm sewer systems in Orlando, Florida**

Source: NRCS



### ***Synthetic Filter Fabrics***

When fine native materials are encountered in the excavation, a filter cloth envelope or wrap should be placed around the coarse aggregate backfill. This practice prevents the migration of fine sediments from the surrounding soil that could clog the trench following reverse flow conditions resulting from high groundwater levels. A multitude of plastic woven or nonwoven filter fabrics can be used for this purpose. However, care should be taken to prevent tearing or puncturing the fabric. Likewise, adjacent sheets should be overlapped 1 to 1/2 feet (30 to 45 cm) and secured to prevent openings from developing.

To ensure good performance, synthetic fabrics (either woven or nonwoven) must be carefully selected, based on the properties required. As with aggregate filters, fabric filters must provide two very important functions, as follows:

1. *They must be able to prevent clogging of the drain by the migration of erodible soil or other material from the substrate into the trench, which could also result in erosion, piping, or other problems.*
2. *They must not inhibit the free flow of water.*

Care should be taken in selecting the proper kind of filter fabric, as available brands differ significantly in their permeability and strength. If desired, a 6-inch (15 cm) deep filter of clean, washed sand may be substituted for filter fabric on the bottom of the trench.

Likewise, the use of filter fabric directly surrounding slotted, corrugated polyethylene pipe has recently become a popular derivation of the typical exfiltration trench design. Within these facilities, the sedimentation and filtration of particulates larger than the silt/clay size range take place within the perforated pipe. Consequently, the pipe is more prone to clogging, and large reductions in capacity occur more often than usual. While this may seem unacceptable, manufacturers point out that the pipe may be cleaned relatively easily using high-pressure hoses, vacuum systems, etc. On the other hand, conventional designs usually require complete replacement when clogging eventually occurs.

### ***Observation Well***

The installation of an observation well is recommended in every infiltration trench. It serves the following two primary functions:

1. *It indicates how quickly the trench dewater following a storm.*
2. *It provides a method of observing how quickly the trench fills up with sediments.*

A simple observation well may consist of perforated polyvinyl chloride (PVC) pipe 4 to 6 inches (10 to 15 cm) in diameter. It is usually located in the center of the facility and is constructed flush

with the ground elevation of the trench, as shown in **Figure 8.2d**. The top of the well should be capped and locked to discourage vandalism and tampering.

The observation well is needed to monitor the performance of the trench and is also useful in marking the trench location. The drain time for a trench can be measured by placing a graduated dipstick down the well immediately after a storm and again 24 and 48 hours later.

For the first year after the completion of construction, the well should be monitored quarterly and after every large storm. It is recommended that a logbook be maintained, indicating the rate at which the facility dewateres after large storms and the depth of the well at each observation. Once the performance characteristics of the structure have been verified, the monitoring schedule can be reduced to a semiannual basis, unless the performance data indicate that a more frequent schedule is required.

A monitoring well in the top 1 foot (30 cm) of stone aggregate is required when the trench has a stone surface. Sediment buildup in the top 1 foot (30 cm) of stone aggregate or the surface inlet should be monitored on the same schedule as the observation well. The sediment deposited shall not be allowed to build up to the point where it significantly reduces the rate of infiltration into the trench.

### ***Overflow***

Unless the facility is designed to accommodate the total amount of anticipated runoff from a large design storm, some provisions should be made for overflow. To provide the maximum benefit in reducing downstream flood peaks, these structures should be designed to overflow before the total storage capacity is reached. There are many ways to accomplish this. Pipes can be used, for instance, to connect a sequence of infiltration facilities, so that when the first one fills, it passes water through to the next one, and so on.

Generally, several smaller facilities are more effective than one large facility, though the latter may be necessary when there are space limitations. The capacity and cost of overflow discharge systems can be reduced by allowing temporary storage space above the infiltration trenches.

Because of the small drainage areas controlled by the exfiltration trench, an emergency spillway usually is not necessary. In all cases, however, the overland flow path of any surface runoff exceeding the capacity of the trench should be evaluated to preclude the development of an uncontrolled, erosive watercourse.

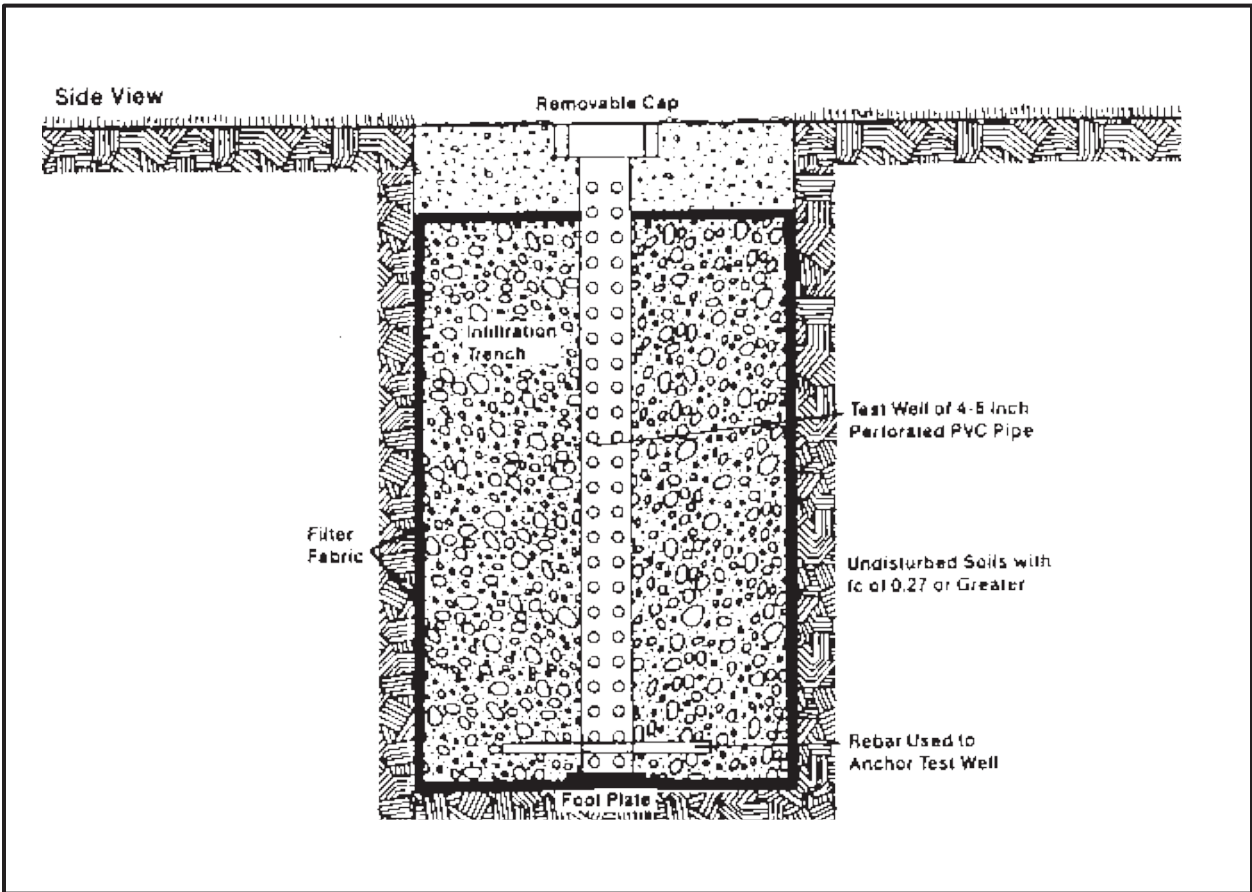

Figure 8.2d. Detailed schematic of a typical observation well

### *Seepage Analysis and Control*

An analysis shall be made to determine any possible adverse effects of seepage zones when there are nearby building foundations, roads, parking lots, or sloping sites.

Developments on sloping sites often require the use of extensive cut-and-fill operations. The use of infiltration trenches on fill sites with steep slopes is not recommended. Fill areas can be very susceptible to slope failure because of slippage along the interface of the undisturbed soil and the fill material. This condition could be further aggravated if the fill material is allowed to become saturated using retention practices. The methods for seepage analysis and the estimation of infiltration rates using Darcy's law and flow nets can be used to conduct the seepage analysis.

When exfiltration trenches are used in residential areas, special care must be taken to prevent seepage from causing unstable soil conditions near foundations. Trenches 3 or more feet (> 0.9 m) deep shall be located at least 10 feet (3 m) downgradient from foundation walls. Trenches should also be no closer than 100 feet (30 m) from wells or septic tanks.

## 8.5 Permeable Surfaces – [Green Infrastructure] [LEED Credits]

### Definition

Permeable surfaces each consist of a wide variety of materials; such as, porous "cold-batched" asphalt with 23 % or greater void spaces, porous concrete with similar void spaces, pavers, geo web or other high-density polyethylene (HDPE) structures, and many other devices that provide for stormwater infiltration and serve as a supporting structural surface for vehicles. Many of these permeable surface systems may be combined with certain water-reducing and retarding or accelerating admixtures, along with air-entraining agents and biotic materials for nutrient removal (see **Figure 8.3**).

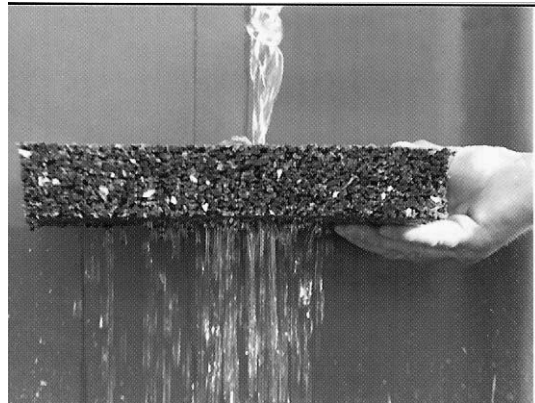

### Purposes

1. *To reduce the volumes and peak rates of runoff normally associated with urban development, thus reducing the potential for combined sewer overflows, downstream channel erosion, and subsequent sediment pollution.*
2. *To improve water quality by filtration and biotic materials to allow bacterial action to reduce and remove nutrients; such as nitrogen and phosphorus and other nutrients.*
3. *To aid in vital groundwater recharge necessary to meet future water supply demands in Florida's future.*

### Applications

Theoretically, the practice can be applied as a direct substitute for conventional concrete or asphalt pavements wherever onsite retention is necessary to control runoff rates, volumes, and/or quality. However, it is most popular for low-volume traffic areas; such as parking areas, with stable subgrade soils having at least moderate permeability. The practice should have a wider range of application in areas with very sandy soils.

Several regulatory agencies in Florida have restricted the use of porous pavement because of failures resulting from a lack of maintenance. The use of this practice should be limited to entities that have demonstrated a capability to maintain the pavement and/or an ability to restrict access to vehicles that have taken precautions such as tire washing. An operating permit (two to five years duration) based on regular performance inspection is another method to safeguard the effectiveness of this practice.

### Construction Specifications

The subgrade shall be prepared following standard practices as described in **EARTHWORK SPECIFICATIONS** (in this chapter) and as directed by a Florida registered professional engineer. Light equipment or low ground pressure equipment should be used to avoid compacting the subsoil. Mixing and placement shall be performed by qualified contractors under the direction of a professional engineer.

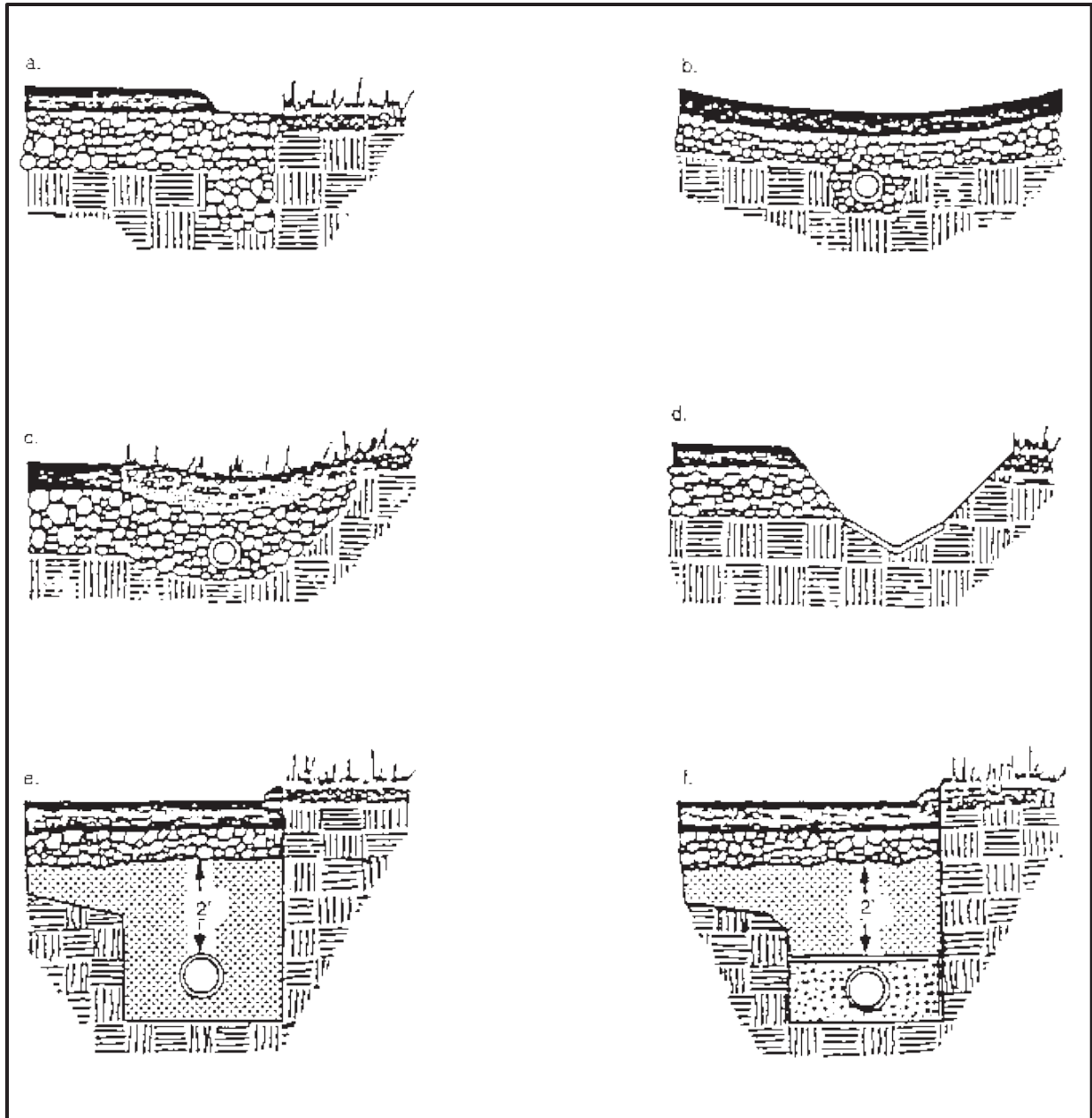

**Figure 8.3. Examples of porous pavement drainage systems**

Source: Thelen et al. 1972

## 8.6 Grid and Modular Pavement – [Green Infrastructure] [LEED Credits]

### Definition

Another permeable surface pavement consisting of strong structural materials with regularly interspersed void areas that are filled with pervious materials, such as sod, gravel, or sand (see **Figure 8.4**).

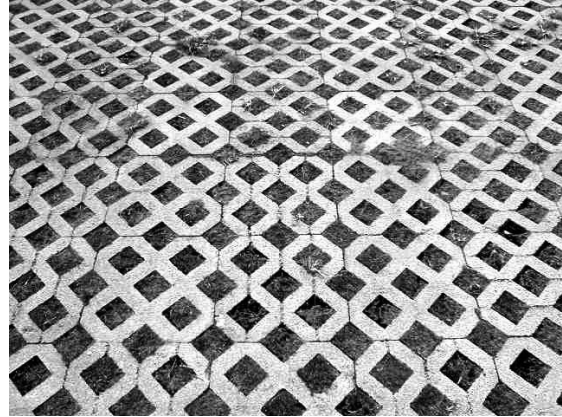

### Purpose

To reduce water pollution from low-volume traffic areas by providing a bearing surface strong enough to accommodate vehicles, while allowing the infiltration of surface water and filtration of pollutants. It achieves this purpose by the following:

1. *Reducing the volume and peak rate of runoff flow, thus reducing the likelihood of sewer overflows, flooding, and downstream erosion and sediment pollution.*
2. *Reducing the loading and concentration of pollutants in runoff.*

### Applications

The practice is used where pavement is desirable or required for low-volume traffic areas and underlying soils allow for rapid drainage. It is best applied to new construction but can be used in existing developments to expand a parking area or even to replace existing pavement, if that is a cost-effective measure. It should **NOT** be used in areas where infiltrated pollutants may reach and degrade groundwater through activities such as fueling, chemical handling, and other pollutant active processing.

Possible areas for the use of these paving materials include the following:

1. *Parking lots, especially fringe or overflow parking areas.*
2. *Parking aprons, taxiways, blast pads, and runway shoulders at airports (heavier loads may require the use of reinforced grid systems).*
3. *Emergency stopping and parking lanes and vehicle crossovers on divided highways.*
4. *On-street parking aprons in residential neighborhoods.*

5. *Parking pads in recreational vehicle camping areas.*
6. *Private roads, easement service roads, and fire lanes.*
7. *Industrial storage yards and loading zones (heavier loads may demand the use of reinforced grid systems).*
8. *Driveways for residential and light commercial use.*
9. *Sidewalks, patios, and swimming pool aprons.*
10. *Boat ramps, bike paths, and nature trails.*

### Construction Specifications

The subgrade shall be prepared following standard practices as described in **EARTHWORK SPECIFICATIONS** (in this chapter) and as directed by a Florida registered professional engineer. Light equipment or low ground pressure equipment should be used to avoid compacting the subsoil. Grid or modular pavement shall be installed according to the manufacturer's specifications. The void spaces can be filled with sand or gravel, or vegetated.

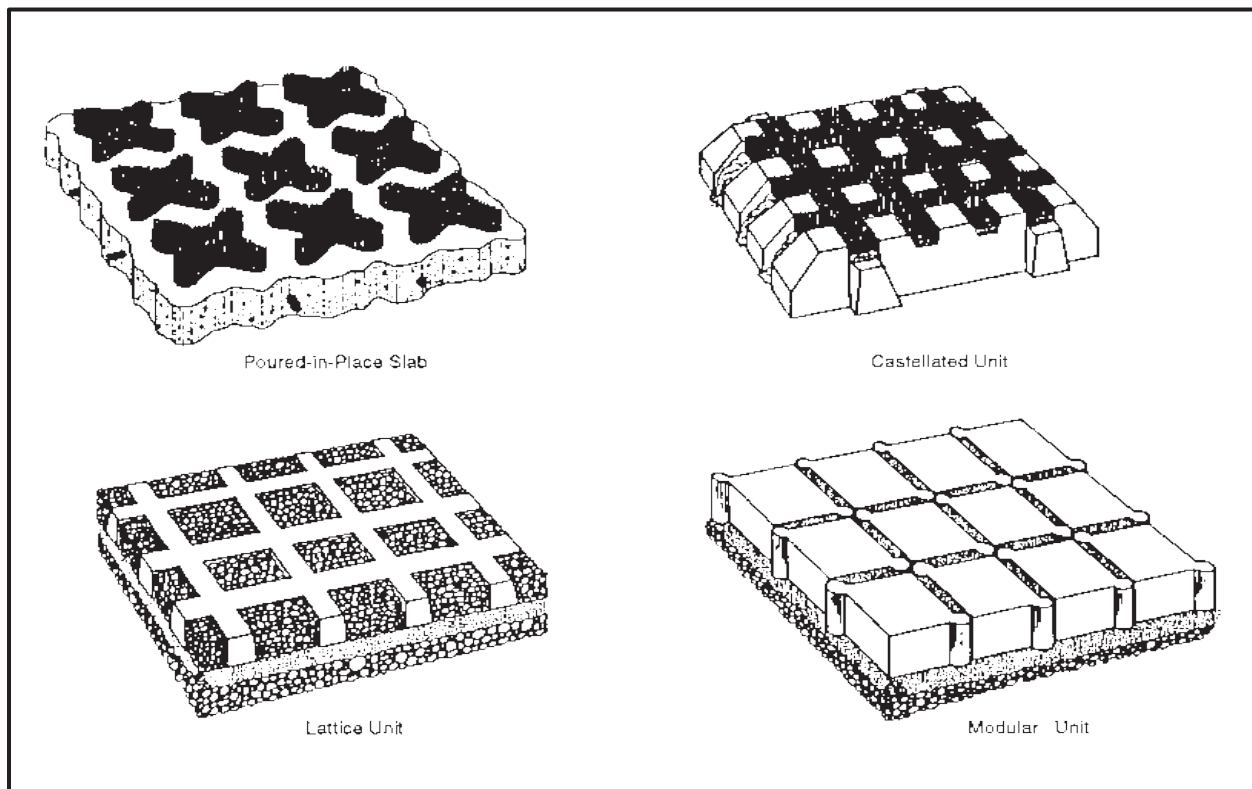

**Figure 8.4. Types of grid and modular pavement**

Source: Virginia SWCC

## 8.7 Stormwater Detention Basin – [Gray and Green Infrastructure]

### Definition

Onsite stormwater detention refers to the temporary storage of excess runoff on a site before its gradual release after the peak of the storm inflow has passed. Runoff is held for a short period and is slowly released to a natural or constructed water course, usually at a rate no greater than the predevelopment peak discharge rate.



### Purposes

A detention facility regulates the runoff from a given rainfall event and controls discharge rates to reduce the impact on downstream stormwater systems, either natural or man-made. Generally, detention facilities do not reduce the total volume of runoff but redistribute the rate of runoff over time by providing temporary "live" storage of a certain amount of stormwater. The volume of this temporary storage is the volume indicated by the area between the inflow and outflow hydrographs, as shown in **Figure 8.5a**.

**Figure 8.5b** shows examples of "dead" storage areas in wet detention ponds. When the inflow and outflow pipes are too close together and directly across the pond from each other, the water shoots straight through the pond without enough time to allow for settling and uptake. The remaining storage capacity of the pond is not being used for storage and settling as it should. This is the "dead" storage area of the pond. One way to alleviate the dead storage is to incorporate earthen berms or baffles to force the water to take a longer flow path to the pond outlet. This provides additional time in the pond for settling and nutrient uptake to occur.

The benefits of properly designed and operated detention facilities include a reduction in downstream flooding problems, the reduced costs of downstream stormwater conveyance facilities, a reduction in pollution of receiving streams, and the enhancement of aesthetics in a development area by providing a core of "blue-green" areas for parks and recreation.



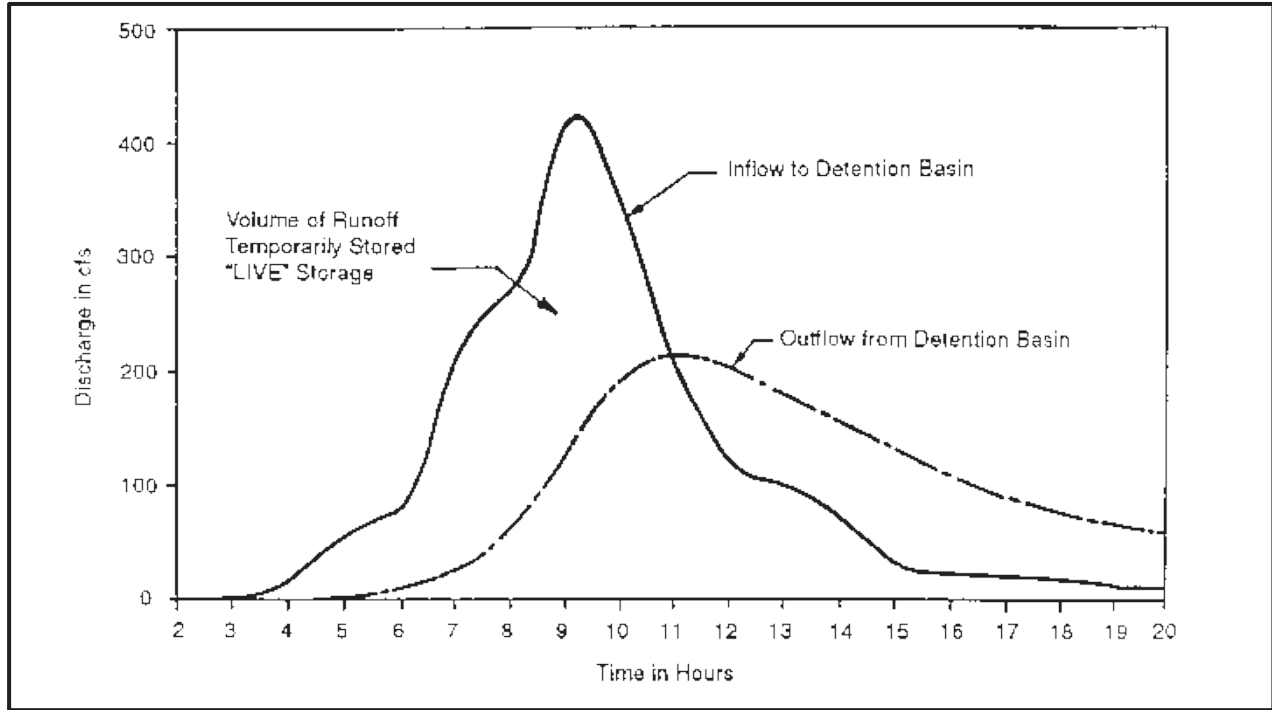

Figure 8.5a. Typical detention basin hydrographs

Source: NRCS

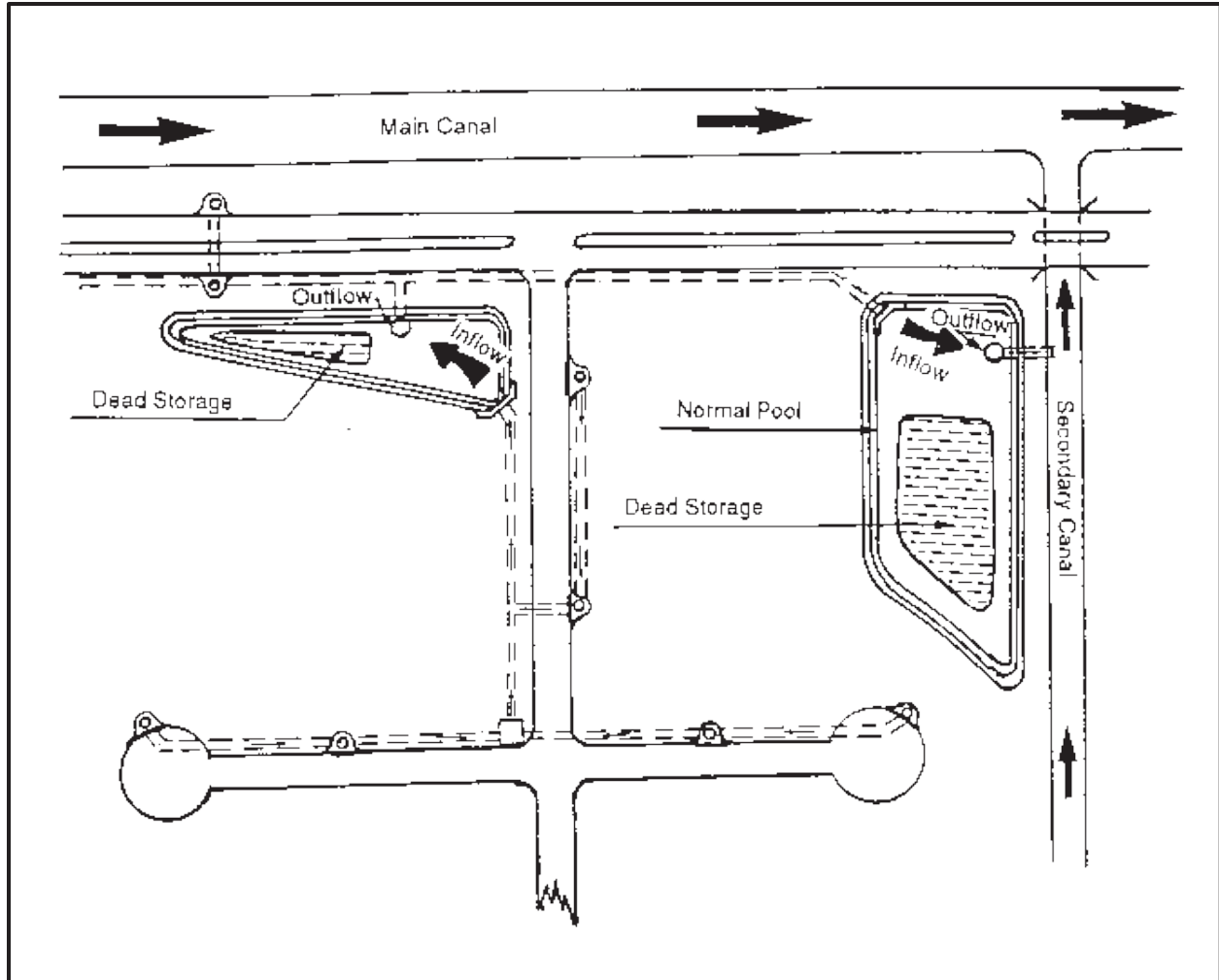

Figure 8.5b. Examples of dead storage areas in wet ponds

Source: NRCS

### Construction Specifications

Initial basin construction should be carried to within 1 foot (30 cm) of the elevation of the basin floor. Interior side slopes should be sodded immediately to prevent erosion and the introduction of additional sediments. Final excavation shall be deferred until all contributing areas of the watershed are stabilized. **Figures 8.5c** and **8.5d** show examples of different configurations for a wet detention system.

Structural elements, such as embankments, inlets, flumes, and emergency spillways, shall be designed by a Florida registered professional engineer. These elements shall be constructed in accordance with **EARTHWORK SPECIFICATIONS** (in this chapter) and other acceptable engineering standards.

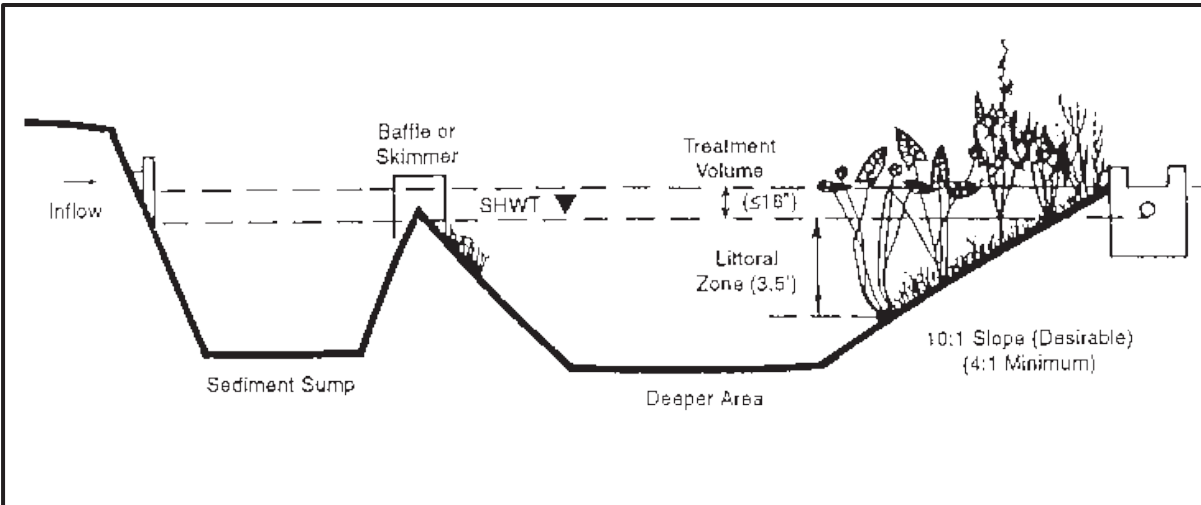

**Figure 8.5c. Wet detention system, pond configuration – A**

Source: Southwest Florida Water Management District (SWFWMD), 1988

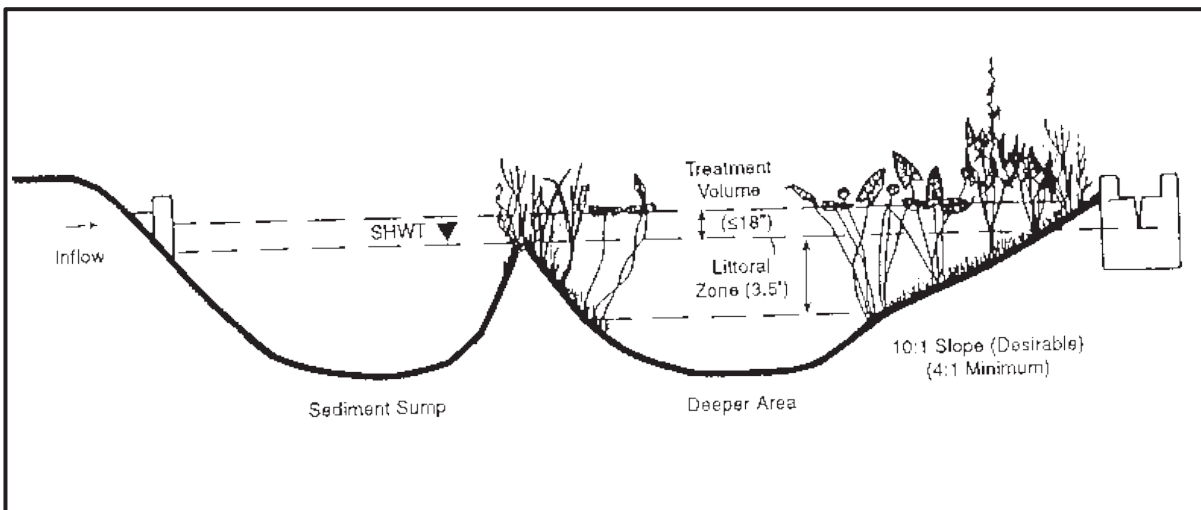

**Figure 8.5d. Wet detention system, pond configuration – B**

Source: SWFWMD 1988

## 8.8 Underdrain and Filtration Systems – [Green Infrastructure] [LEED Credits]

### Definition

Stormwater underdrain and filtration systems usually consist of a conduit, such as a pipe and/or a gravel-filled trench, that intercepts, collects, and conveys stormwater following infiltration and percolation through the soil, suitable aggregate, and/or filter fabric.

### Purposes

In Florida, these systems serve one or more of the following purposes:

1. *To filter a portion (normally 1/2 to 1 inch) (13 to 25 mm) of the stormwater runoff contained in detention facilities prior to discharge to surface waters.*
2. *To alter the soil environment in treatment areas that are not suitable for desired vegetation, usually by regulating the period of inundation, the water table elevation, and/or the inflow of shallow groundwater.*
3. *To improve the infiltration and percolation characteristics of the soil in stormwater management facilities when permeability is restricted because of soil texture or a high water table.*



### Applications

Underdrain systems and filters are used in combination with a variety of stormwater management measures where space, soil permeability, and/or water table conditions dictate that sufficient pollutant removal cannot normally be achieved through natural percolation, sedimentation, or other means. A gravity outlet must be available, or pumping must be provided. A pumped discharge usually requires a permit from DEP and/or the local water management district.

### Construction Specifications

All drains shall be laid to line and grade, surrounded by at least 3 inches (8 cm) of washed gravel, and wrapped in filter fabric. The trench bottom must be uniformly smooth and made up of either undisturbed soil or properly compacted fill, especially if the trench is cut into rock. Joints between sections of rigid pipe shall not exceed 1/4 inch (3 mm). The ends of pipes shall be capped, or preferably connected to cleanouts.

Backfill shall be as outlined in **EARTHWORK SPECIFICATIONS** (in this chapter). **Figures 8.6a through 8.6e** show additional specifications.

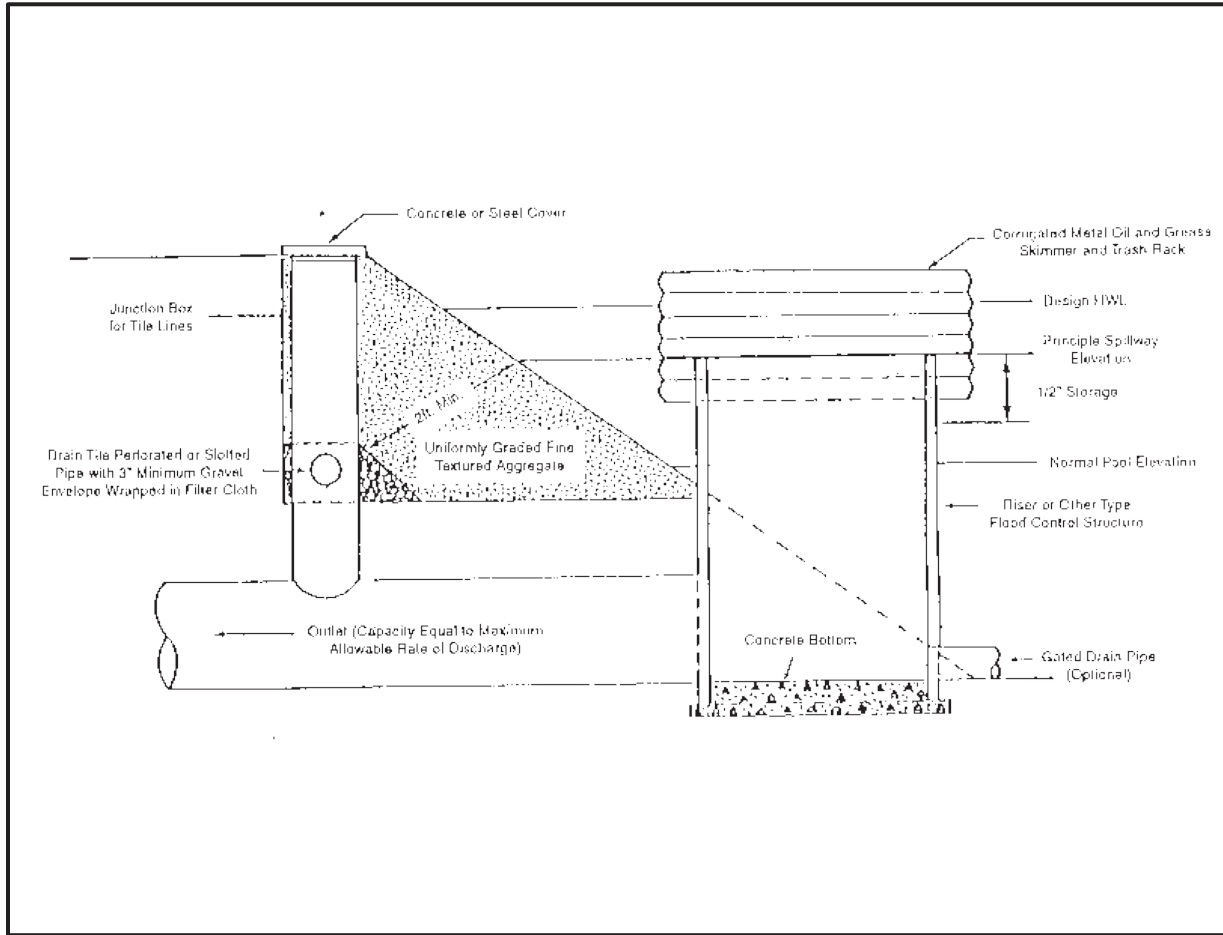

**Figure 8.6a. Cross-section of stormwater discharge structure with "mixed media" bank filter system**

Source: NRCS

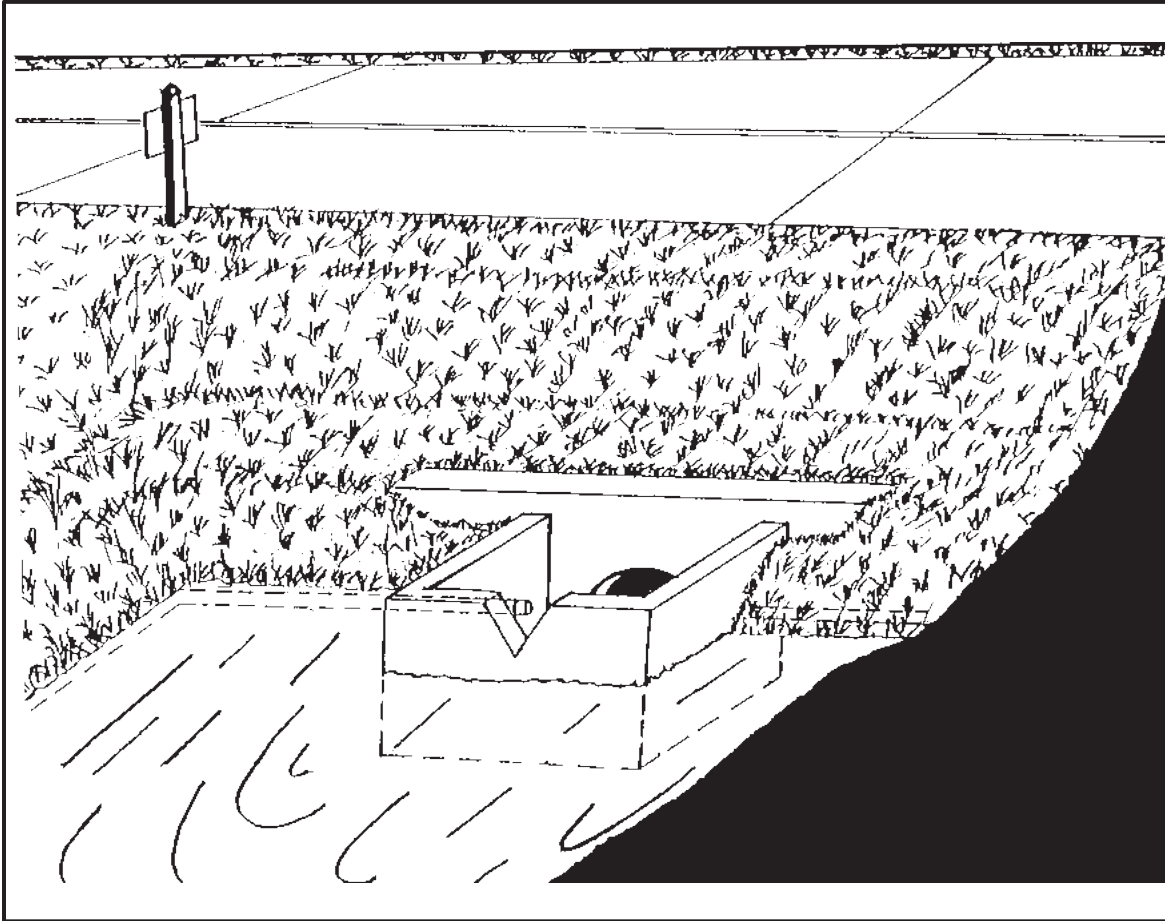

**Figure 8.6b. Illustration of typical "natural soil" bank filtration system with box inlet drop spillway and "V" notched weir (wet retention facility)**

Source: NRCS

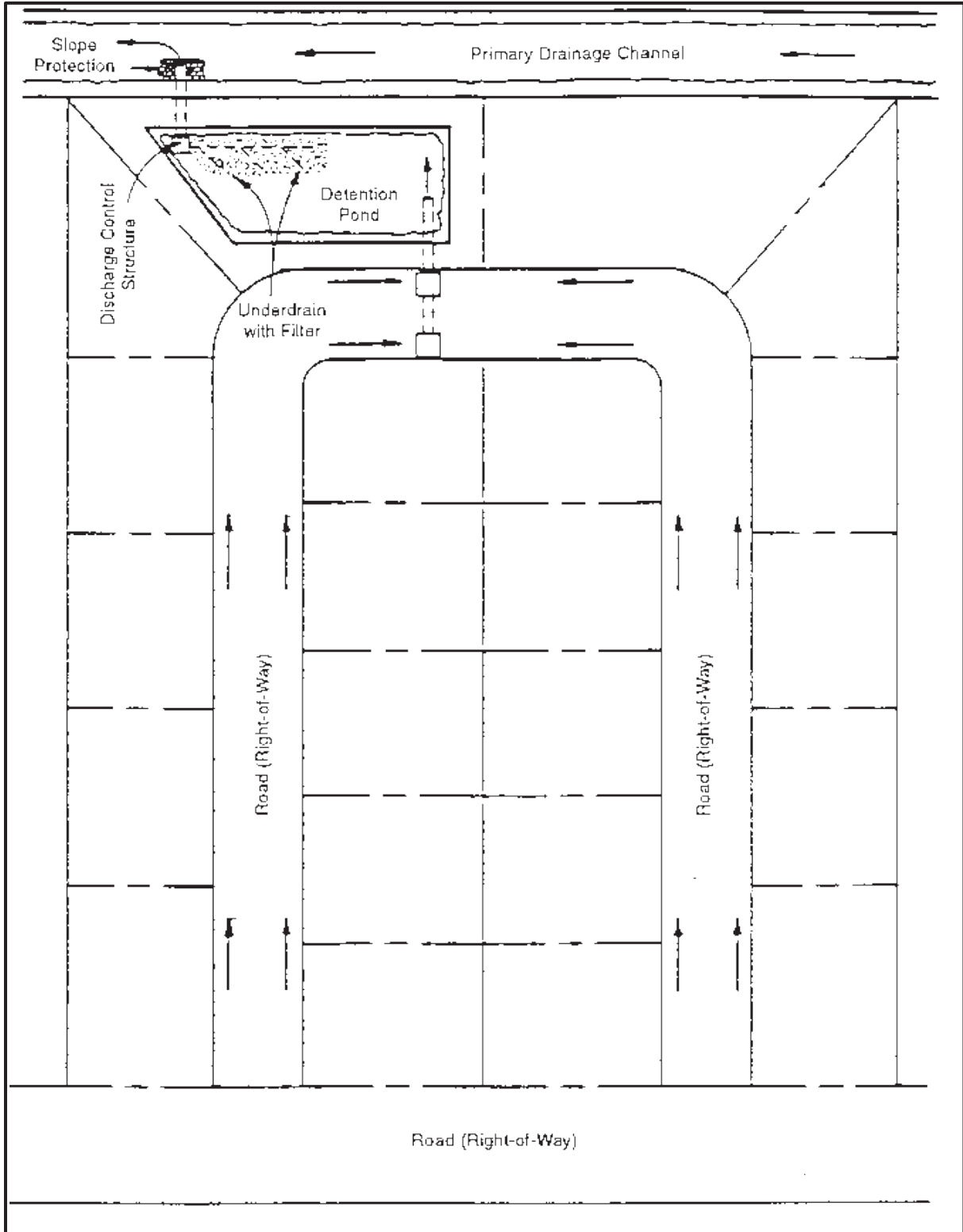

**Figure 8.6c. Typical subdivision layout showing online detention pond and outfall**

Source: Pinellas Park Water Management District

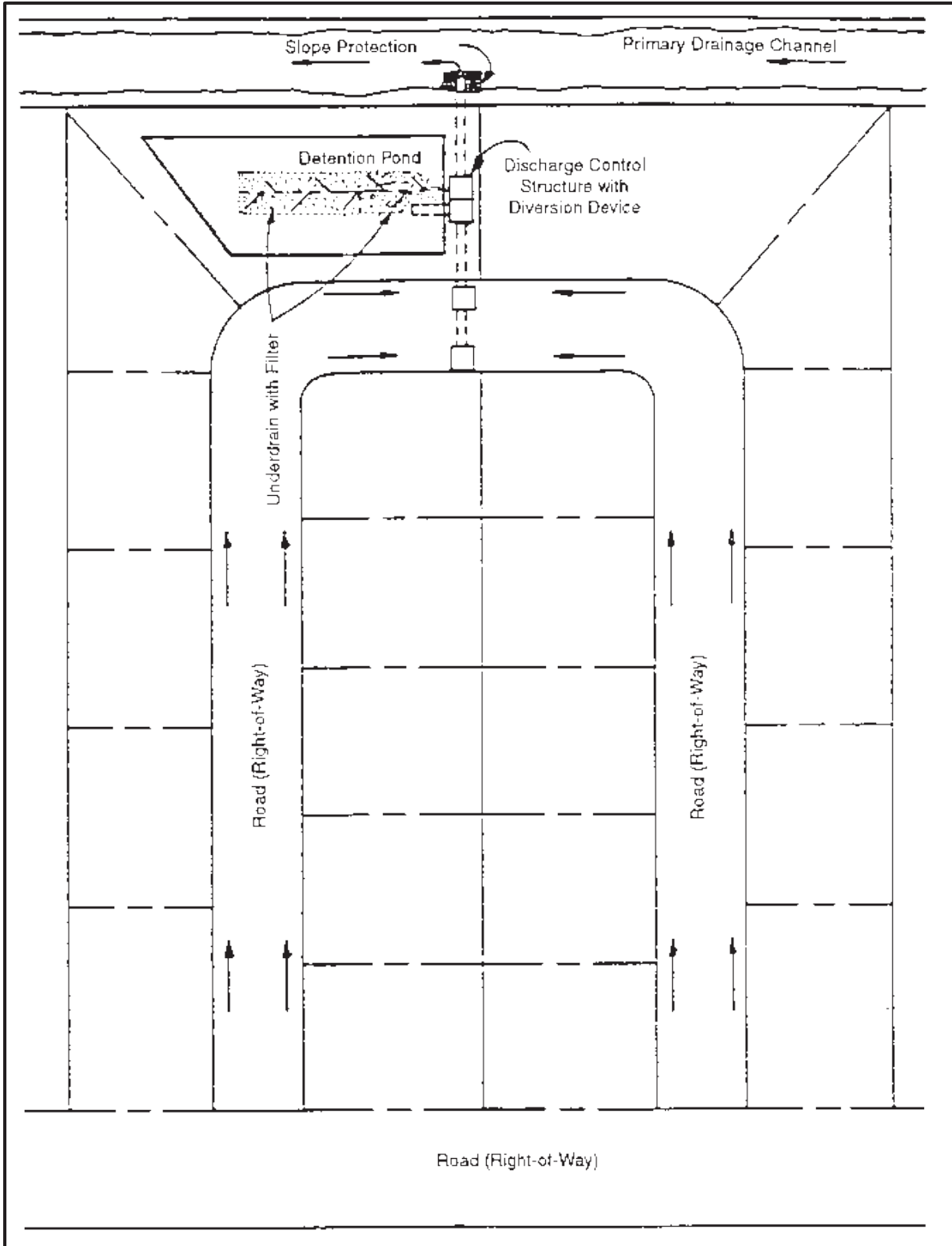

**Figure 8.6d. Typical subdivision layout showing offline detention pond and outfall**

Source: Pinellas Park Water Management District



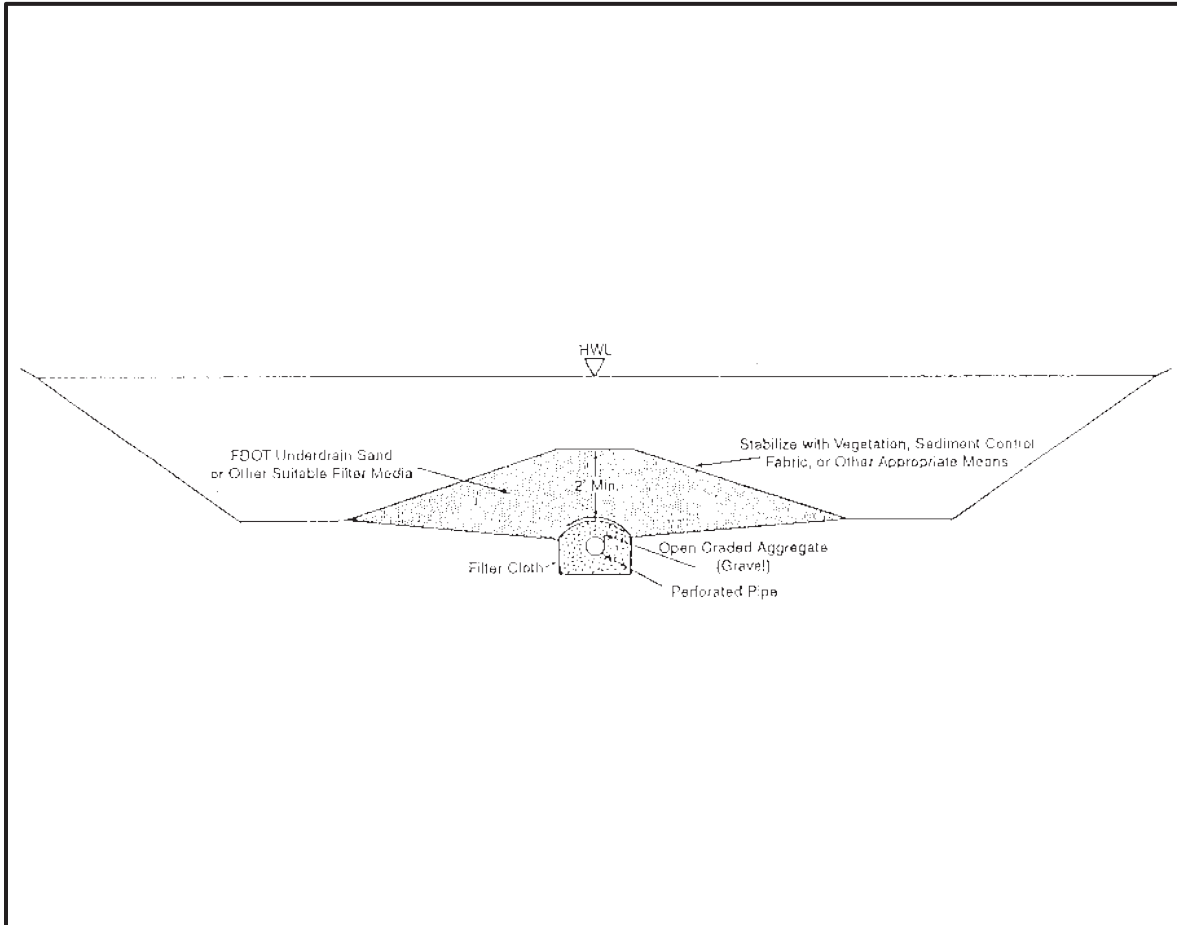

**Figure 8.6e. Typical cross-section of elevated sand filter for stormwater treatment used in conjunction with dry detention facility**

Source: NRCS

## 8.9 Swales, Bioswales, and Vegetative Swales – [Green Infrastructure] [LEED Credits]

### Definition

1. *Swales (or grassed waterways) are constructed conveyances shaped or graded to the required dimensions and established with suitable vegetation for the safe disposal and treatment of runoff (see **Figures 8.7a** and **8.7b**).*
2. *Chapter 403, F.S., further defines the term "swale" as requiring a cross-section with a top width-to-depth ratio of 6:1 or greater, or side slopes of 3 horizontal to 1 vertical or flatter. It also specifies that the conveyance must only contain standing or flowing water following a storm, must be planted with or have stabilized vegetation, and must be designed to prevent erosion and reduce pollutant concentrations.*
3. *A bioswale and vegetated swale is a form of bioretention used to partially treat stormwater runoff, attenuate flooding, and transport stormwater away from critical infrastructure. These systems are linear in design, with length-to-width dimensions much greater than the more typical 2:1 applied to bioretention cells. (Florida Field Guide to Low Impact Development, UF–IFAS 2008).*



### Purposes

1. *Swales are used primarily to convey stormwater safely without erosion.*
2. *It is the usual practice to use existing topographic draws and rework them as needed.*
3. *With slight modifications to increase the retention and infiltration of runoff, swales can be used to treat and remove pollutants such as sediments and nutrients from stormwater runoff in urban situations.*

### Applications

Swales are used at all sites where added capacity, vegetative protection, or both, are required to control erosion and/or reduce the pollutant load from concentrated stormwater runoff. They are also used as a pretreatment BMP in combination with other BMPs. Examples of uses include the following:

1. Providing outlets for diversions and terraces.
2. Providing conveyances to, or outlets from, surface and subsurface detention and filtration systems.
3. Conveying and treating stormwater collected along roadways or discharged from residential buildings, yards, and vehicle use areas.
4. Rehabilitating or stabilizing natural draws carrying concentrations of runoff.
5. Providing for, or improving, the percolation and treatment of stormwater.
6. Using as pretreatment practices to reduce stormwater pollutant loads before conveying stormwater to other BMP locations.

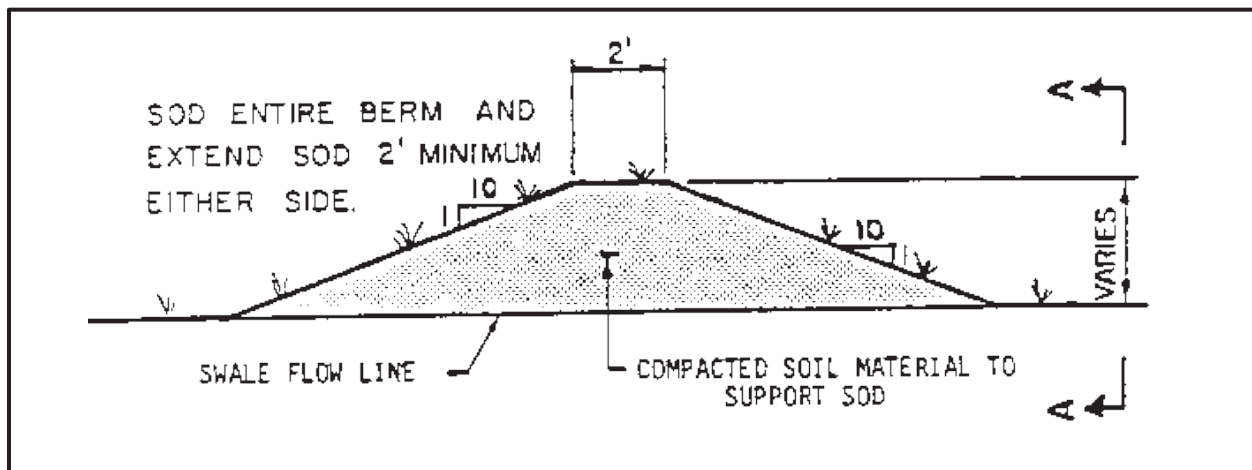

Figure 8.7a. Typical swale block cross-section

Source: NRCS

## Construction Specifications

### Equipment

Many kinds of farming and construction equipment can be used for building grassed swales. However, it may be necessary to use equipment that can load and transport the excavated material to locations where it is needed. These points of need might be low spots in the surrounding area or washes in the conveyance that need filling. Small scrapers that can be pulled by farm tractors are satisfactory units for construction.

However, large scrapers, bulldozers, and road graders are excellent types of equipment for constructing these systems and may be more efficient.

### ***Site Preparation***

The swale should be staked for construction. All trees, stumps, brush, and similar material should be removed from the site and disposed of, so as to not interfere with the proper functioning of the system. Design and construction survey notes should be kept according to standard engineering practice.

### ***Excavation***

The soil removed from the swale should be deposited where it will not interfere with the flow of water into the swale. Normally it can be used to fill low spots or build diversions to keep runoff from the swale during vegetation establishment.

The topsoil should be saved and spread in the constructed swale if necessary to ensure the establishment of a good vegetative cover. When this is done, the swale should be overexcavated to allow for the replacement of the topsoil without encroaching on the design cross-section.

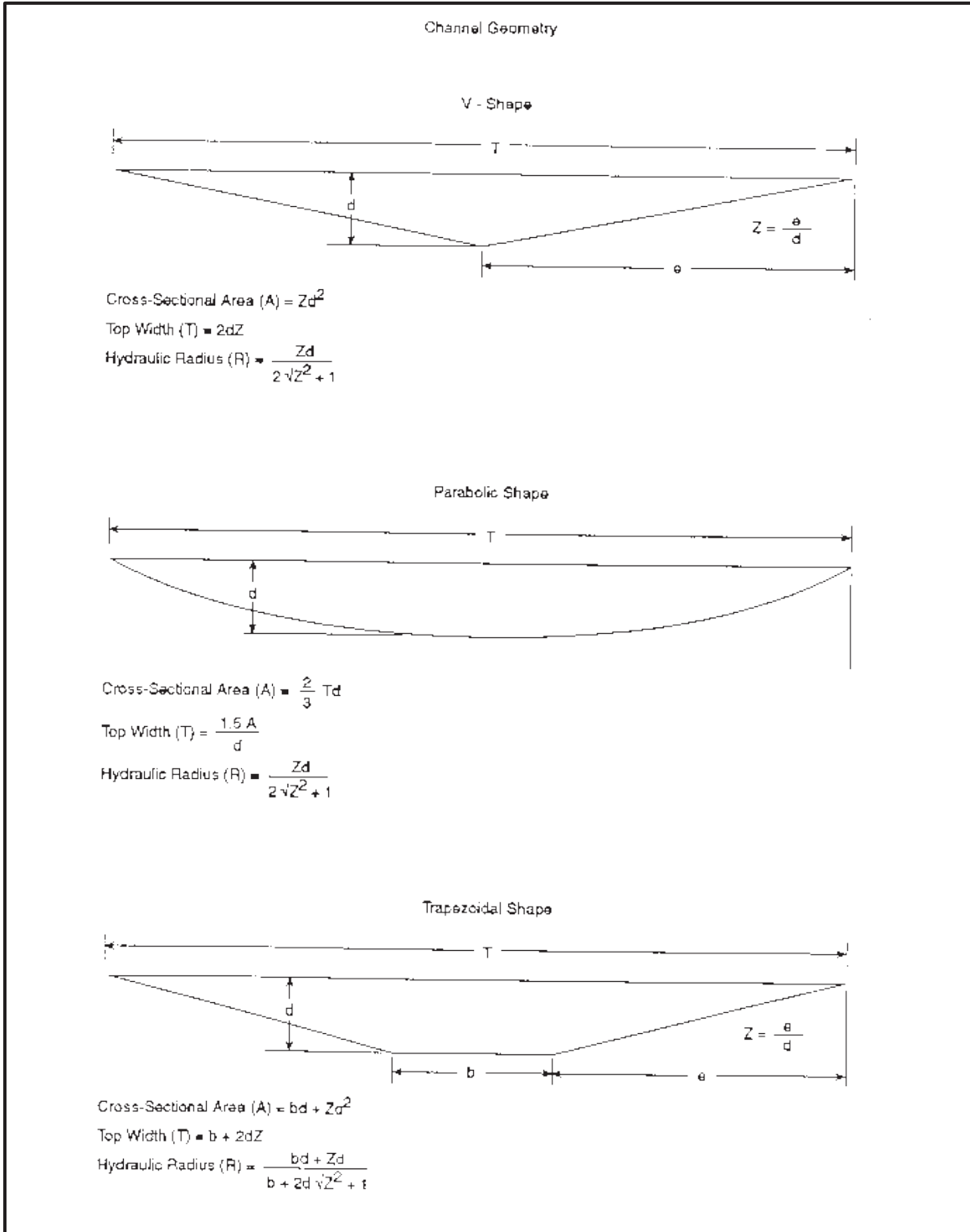

**Figure 8.7b. Typical waterway shapes and mathematical expressions for calculating cross-sectional area, top width, and hydraulic radius**

Source: NRCS

### Establishing Vegetation

The method used to establish grass in a swale depends on the severity of the conditions encountered. **Table 8.1** lists the four different alternatives for grass establishment and the conditions under which each method should be used. For each technique, if any one of the four sets of conditions is exceeded, the next technique below it must be used.

**Table 8.1. Grass establishment alternatives**

Establishment Technique	Conditions
<b>1a. Hydroseeding</b>	Slopes less than 5 %. Velocity less than 3 feet (1 m) per second.
<b>1b. Establishing Bermuda grass by sprigging</b>	Majority of drainage can be diverted away from channel during germination and establishment. Erosion-resistant soil.
<b>2. Seeding with straw mulch and jute mesh or erosion netting</b>	Slopes less than 5 %. Velocity less than 5 feet (1.5 m) per second. Majority of drainage cannot be diverted from channel during germination and establishment. Moderately erodible soil.
<b>3. Sodding</b>	Slopes greater than 5 %. Velocity between 5 and 6 feet (1.5 to 1.8 m) per second. Majority of drainage cannot be diverted away from channel during germination and establishment. Highly erodible soil.

The details for each alternative are as follows:

- 1a. **Hydroseeding.** All seeding shall be done in accordance with **PERMANENT SEEDING** (in **Chapter 4**). When mulching, use 2 tons per acre (4.4 t/ha) small grain straw with an acceptable tacking agent (see **MULCHING** [in **Chapter 4**]).
- 1b. **Establishing Bermuda grass by sprigging.** Irrigation water must be available during the first four weeks. Divert drainage away from the channel during the first three weeks of the establishment period by using temporary berms, silt fencing, or straw bale barriers.
2. **Seeding with straw mulch and jute mesh or erosion netting.** In addition to Item 1.a above, secure straw mulch with netting. If using jute mesh, use only 1 ton per acre (2.2 t/ha) small grain straw, evenly distributed. If using a light plastic or paper erosion netting, 1 1/2 to 2 tons per acre (3.3 to 4.4 t/ha) of straw is appropriate. Care should be taken to staple the mesh or netting according to the specifications in **MULCHING** (in **Chapter 4**). Many types of erosion control mats and blankets, used alone, are acceptable mulches for the establishment of swales. Some of these products are also preseeded.
3. **Sodding.** When using strip sod, follow the recommendations in **SODDING, Installation, Part D** (in **Chapter 4**). Another suitable product is rolled sod, which comes on rolls 2 to 5 feet (60 to 150 cm) wide and 50 to 100 feet (15 to

30 m) long. The sod is grown through a plastic mesh that offers additional strength and erosion resistance.

The swale and its outlet shall be protected against erosion by vegetative cover as soon after construction as practical and before diversions or other channels are connected to them.

### ***Details of Swale Block Construction***

Swale blocks may be constructed using a variety of materials, including wood, concrete, asphalt, metal, natural soil, or a mixture of each. The most common application is the use of native, in-place soil shaped into the form of a low berm. Regardless of the material or materials chosen to form the restriction, the designer should take proper precautions to ensure that the facility is not subject to undercutting and erosion, especially along its toe.

**Figure 8.7a** shows a typical cross-section of a berm-type system. Research conducted by the University of Central Florida (UCF) on 3 existing swale block systems indicated that these systems remained in place more than 2 years after their construction. Washout did not occur, even though 3 storms greater than 3 inches (8 cm) were recorded during this period.

Swale block height should be limited to 1.5 feet (45 cm) for public safety and roadway subgrade protection. It is also recommended that the following guidelines be applied to ensure good structural integrity and easy maintenance (mowing):

- 1. The front and back slope of the structure should not be steeper than 10 feet horizontal to 1 foot vertical, unless pavement or another equally stable material is used to protect the berm from erosion during overflow conditions.*
- 2. Berms should be constructed of clean, stable material suitable for the construction of embankments. The material should be free from tree roots, construction debris, and other extraneous material. The UCF researchers used clayey sand that was mechanically compacted. Inorganic silts, organic silts, and organic clays, as well as peat or other highly organic soil, should not be considered. The designer should also be aware that vegetative cover may be hard to establish when using highly permeable material, such as FDOT washed sand.*
- 3. Sod should be used to protect these embankments from erosion. Protection should be provided extending at least 2 feet (60 cm) from the toe of the berm along both the face and back slope of the structure.*

## 8.10 Stormwater Conveyance Channel – [Gray Infrastructure]

### Definition

A permanent, designed waterway, shaped and lined with appropriate vegetation or structural material to safely convey excess stormwater runoff from a developing area.



### Purpose

To convey concentrated surface runoff water without damage from erosion.

### Applications

The practice is generally applicable to man-made channels, including roadside ditches, and intermittent natural channels that are modified to accommodate increased flows from land development. It is not applicable to major, continuously flowing natural streams.

### Construction Specifications

#### General

1. *All trees, brush, stumps, roots, obstructions, and other unsuitable materials shall be removed and properly disposed of.*
2. *The channel shall be excavated or shaped to the proper grade and cross-section, plus considering the type of channel lining.*
3. *All fills shall be well-compacted to prevent unequal settlement.*
4. *Any excess soil shall be removed and properly disposed of.*

#### Grass-Lined Channels

Grass shall be established in accordance with SWALES (in this chapter) and Chapter 4 of this manual.

#### Concrete-Lined Channels

Concrete-lined channels must be constructed in accordance with all applicable FDOT specifications. The following summary is provided only as a guide:

1. *The subgrade should be moist when the concrete is poured.*
2. *Traverse joints for crack control should be provided at approximately 20-foot (6 m) intervals and when more than 45 minutes elapses between the times of consecutive concrete placements. All sections should be at least 6 feet (1.8 m) long. Crack control joints may be formed by using a 1/8-inch (3 mm) thick*



*removable template, by scoring or sawing to a depth of at least 3/4 inch (19 mm), or by an approved "leave in" type insert (see **Figure 8.8a**).*

3. *Expansion joints shall be installed every 100 feet (30 m).*

### ***Riprap-Lined Channels***

Riprap shall be installed in accordance with **RIPRAP** (in this chapter) (see **Figure 8.8b**).

### ***Gabion Mattresses***

Recently, FDOT in north Florida introduced the use of gabion mattresses to replace paved ditch that was being destroyed by the growth of pine tree roots. These mattresses are constructed of stainless steel wire baskets that are filled to the top with 4- to 6-inch size riprap. The tree roots can grow through the mattresses without causing the damage that once destroyed the paved flumes and ditches. These same gabions can be used for coastal and foreshore protection works as well.



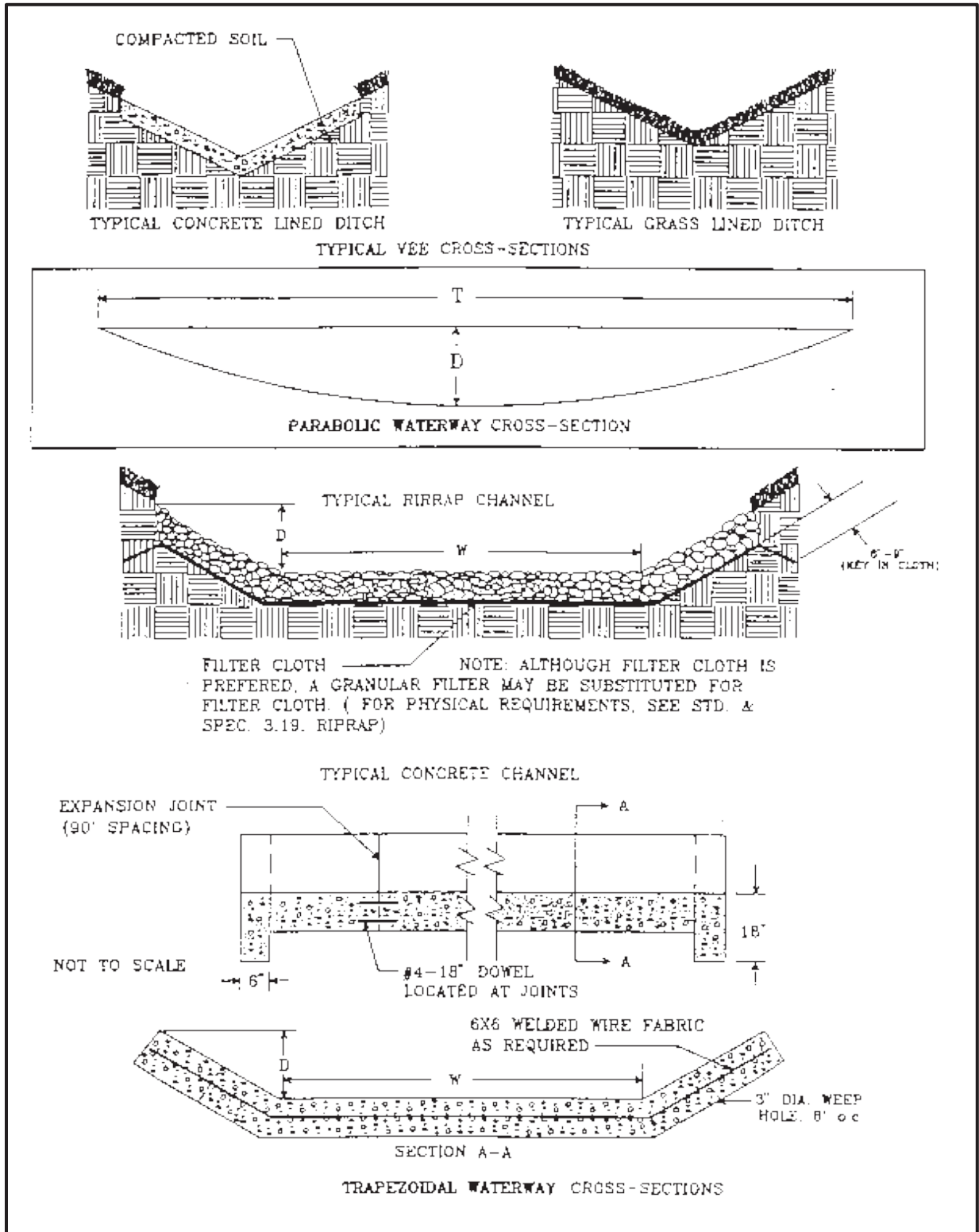
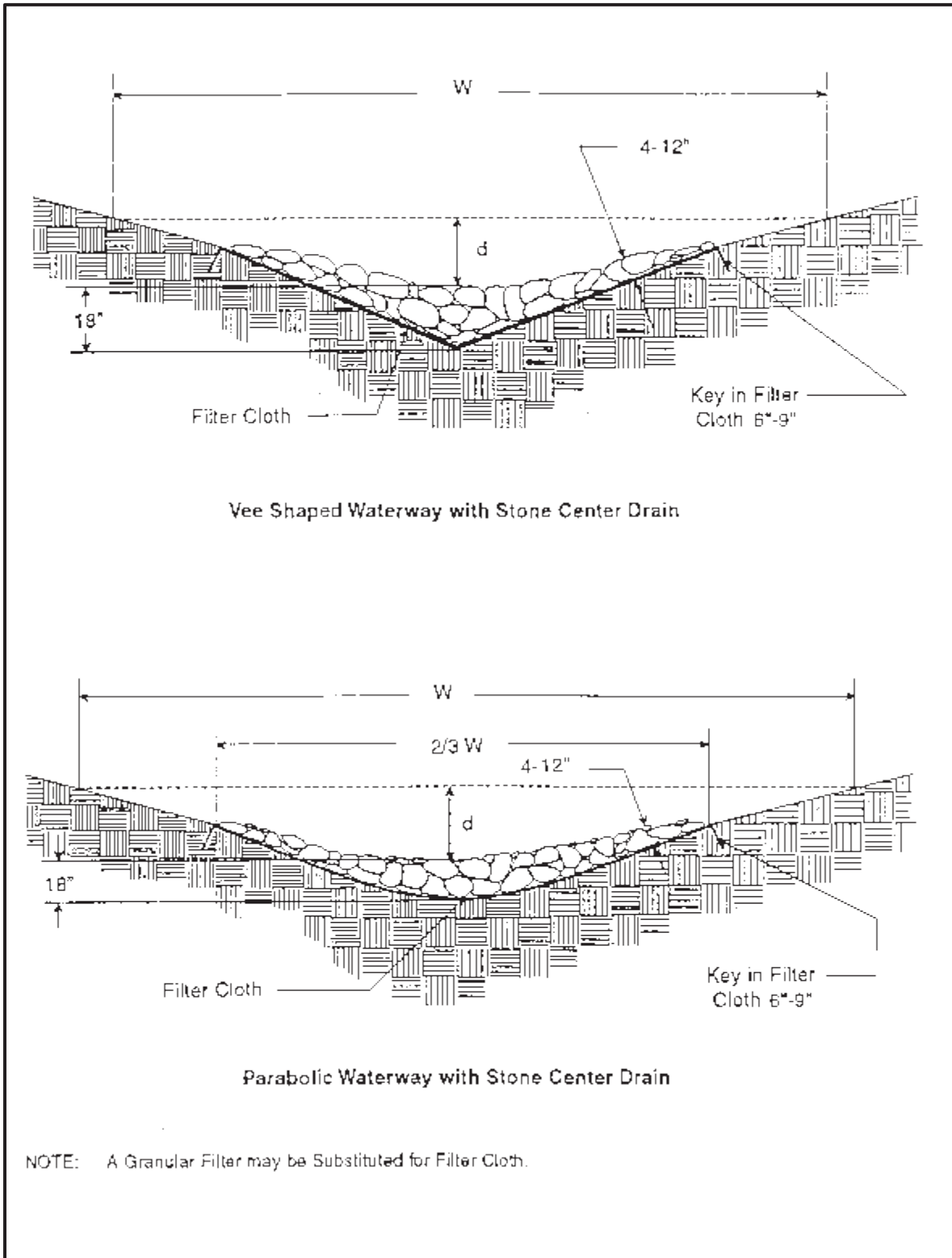

Figure 8.8a. Typical waterway cross-sections

Source: Virginia DSWC



**Figure 8.8b. Typical stone-lined waterways**

Source: NRCS

## 8.11 Paved Flume

### Definition

A permanent, concrete-lined channel constructed on a slope (see **Figure 8.9**).

### Purpose

To conduct stormwater runoff safely down the face of a slope without causing erosion problems on or below the slope.

### Applications

The practice is used wherever concentrated stormwater runoff must be conveyed from the top to the bottom of cut-or-fill slopes on a permanent basis.



### Planning Considerations

Paved flumes are used routinely on highway cuts and fills to convey concentrated stormwater runoff from the top to the bottom of a slope without erosion. Fortunately, these structures have equal applicability to cut-and-fill slopes for construction projects other than highways.

### Construction Specifications

On steep slopes, paved flumes shall be constructed of concrete on undisturbed soil or properly compacted fill. Trenches for anchor lugs and curtain walls shall be dug by hand. The subgrade should be moist during concrete placement. Curtain walls and anchor lugs should be poured monolithic with the flume slab. If conditions dictate, these may be poured separately, provided that the designing professional engineer approves a proper construction joint with dowels and keyway.

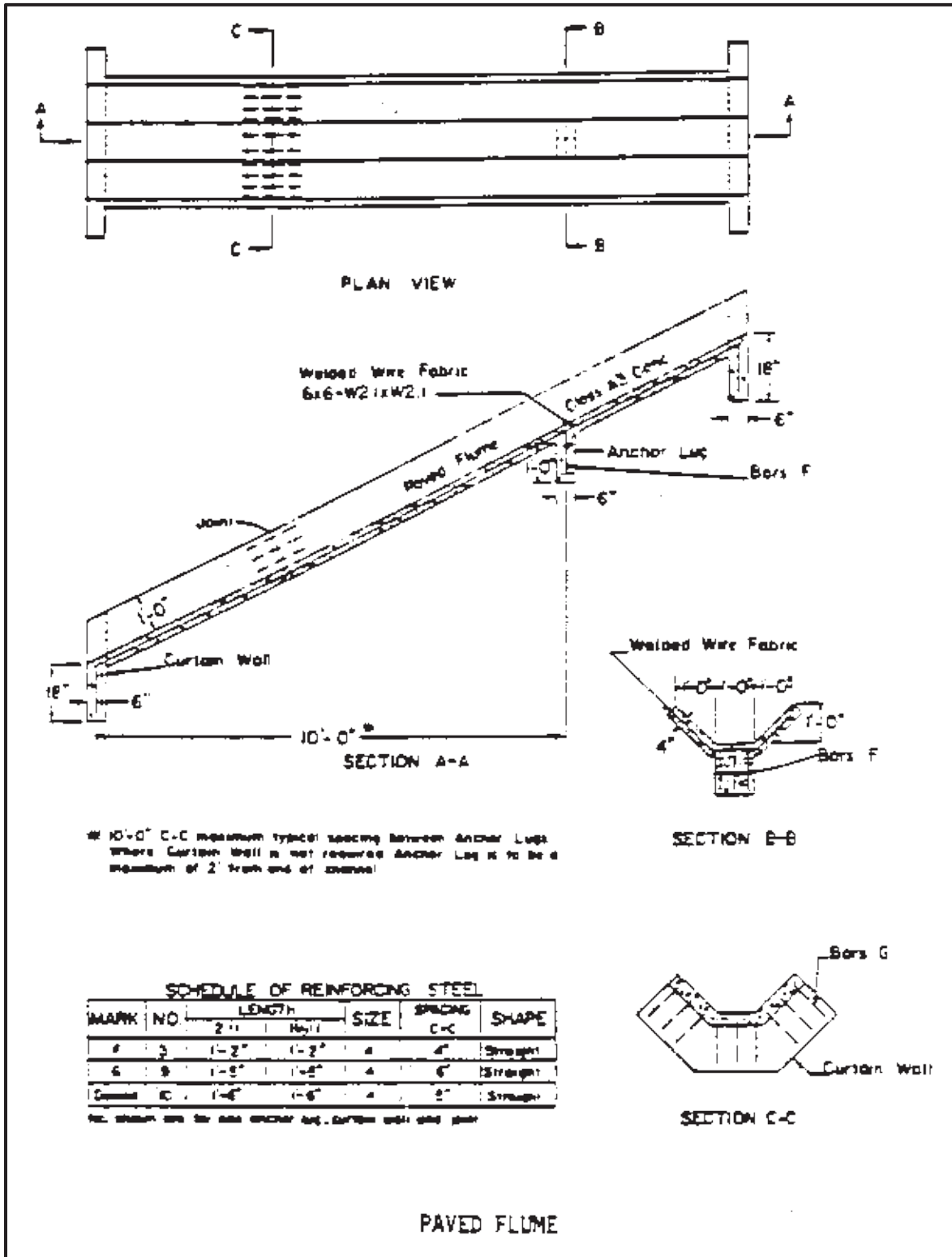

Figure 8.9. Paved flume

Source: Virginia D&HT

## 8.12 Diversion

### Definition

A channel constructed across a slope with a supporting ridge on the lower side.

### Purpose

To reduce slope length and to intercept and divert stormwater runoff to stabilized outlets at nonerosive velocities.

### Applications

- 1. Where runoff from higher areas may damage property, cause erosion, or interfere with the establishment of vegetation on lower areas.*
- 2. Where surface and/or shallow subsurface flow are damaging upland slopes.*
- 3. Where the slope length needs to be reduced to minimize soil loss.*
- 4. Diversions are applicable only below stabilized or protected areas. They should not be used below high sediment-producing areas, unless land treatment practices or structural measures designed to prevent damaging accumulations of sediment in the channels are installed with or before the diversions.*
- 5. Diversions should not be placed on slopes greater than 15 %.*



### Planning Considerations

Diversions can be useful tools for managing surface water flows and preventing soil erosion. On moderately sloping areas, they may be placed at intervals to trap and divert sheetflow before it has a chance to concentrate and cause rill and gully erosion. They may be placed at the top of cut-or-fill slopes to keep runoff from upland drainage areas off the slope. They can also be used to protect structures, parking lots, adjacent properties, and other special areas from flooding.

Diversions are preferable to other types of constructed stormwater conveyance systems because they more closely simulate natural flow patterns and characteristics. Flow velocities are generally kept to a minimum. When properly integrated into the landscape design of a site, diversions can be visually pleasing as well as functional.

As with any earthen structure, it is very important to establish adequate vegetation as soon as possible after installation. It is equally important to stabilize the drainage area above the diversion so that sediment will not enter and accumulate in the diversion channel.

Diversions should be constructed before clearing and grading operations begin. If used to protect a flat, exposed area, a diversion might be constructed as a dike or berm. Berms made of gravel or stone can be crossed by construction equipment.

## **Design Criteria**

### ***Location***

A diversion's location shall be determined by considering outlet conditions, topography, land use, soil type, length of slope, seepage planes (where seepage is a problem), and development layout.

### ***Capacity***

1. *The diversion channel must have a minimum capacity to carry the runoff expected from a 10-year storm with a freeboard of at least 4 inches (10 cm) (see **Figure 8.10**).*
2. *Diversions designed to protect homes, schools, industrial buildings, roads, parking lots, and comparable high-risk areas, and those designed to function in connection with other structures, shall have sufficient capacity to carry peak runoff expected from a storm frequency consistent with the hazard involved.*
3. *The peak rates of runoff used in determining the capacity requirements shall be as outlined in this manual or by other accepted methods.*

### ***Channel Design***

The diversion channel may be parabolic, trapezoidal, or V-shaped, and shall be designed and constructed according to **STORMWATER CONVEYANCE CHANNEL** (in this chapter) (see **Figures 8.8a** and **8.8b**).

### ***Ridge Design***

The supporting ridge cross-section shall meet the following criteria (see **Figure 8.10**):

1. *The side slopes shall be no steeper than 2:1 and shall be flat enough to ensure ease of maintenance of the structure and its protective vegetative cover.*
2. *The width at the design water elevation shall be a minimum of 4 feet (1.2 m).*
3. *The minimum freeboard shall be 4 inches (10 cm).*
4. *The design shall include a 10 % settlement factor.*

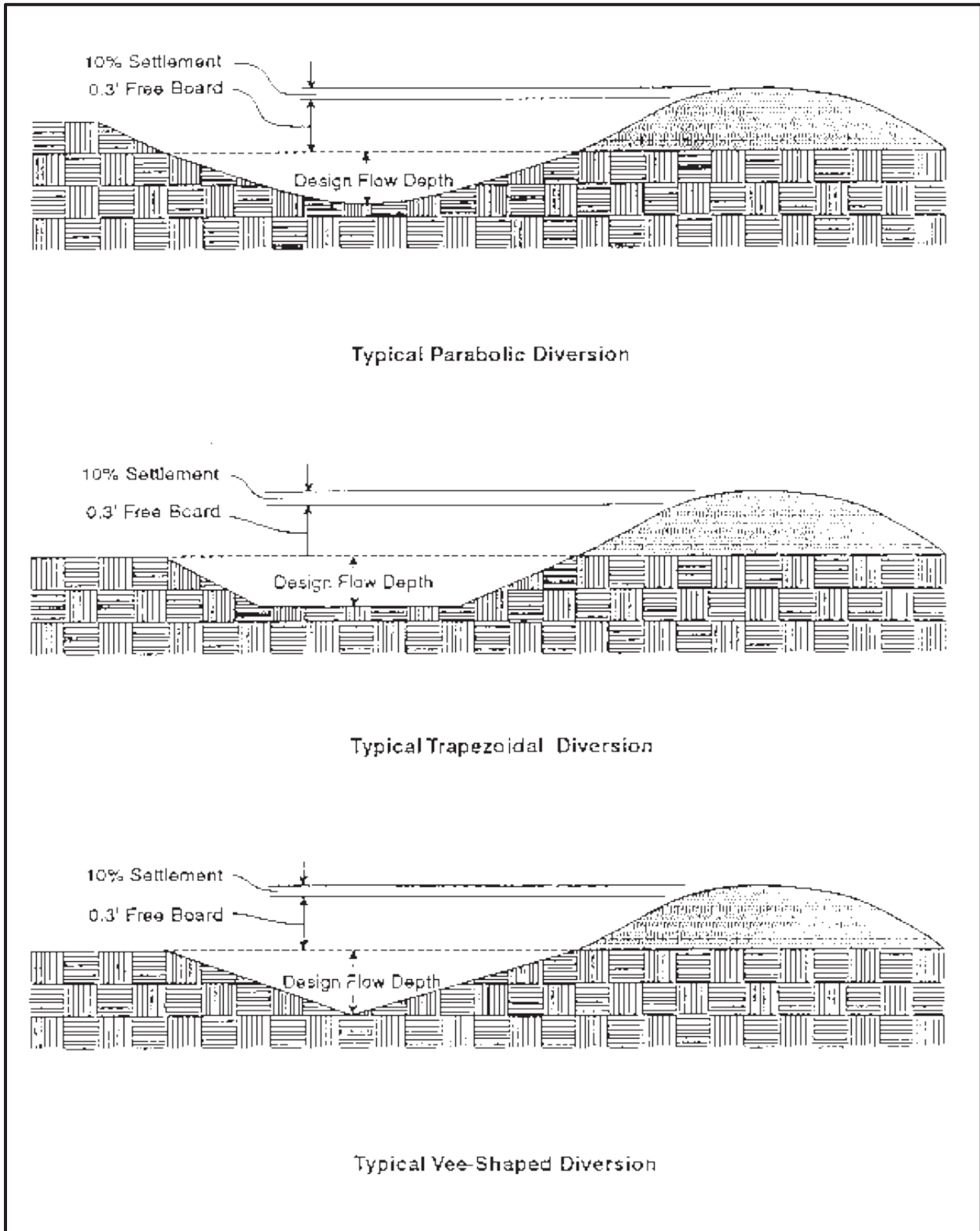

**Figure 8.10. Types of diversions**

Source: Virginia DSWC



### **Outlets**

Diversions shall have stabilized outlets that will convey concentrated runoff without erosion. Acceptable outlets include **PAVED FLUME**, **STORMWATER CONVEYANCE CHANNEL**, and **OUTLET PROTECTION** (in this chapter). Outlets shall be constructed and stabilized prior to the operation of the diversion.

### **Stabilization**

1. *Unless otherwise stabilized, the ridge and channel shall be seeded and mulched within 15 days of installation in accordance with **PERMANENT SEEDING** (in **Chapter 4**).*
2. *Disturbed areas draining into a diversion shall be seeded and mulched prior to or at the time the diversion is constructed.*
3. *Permanent diversions should include a filter strip of close-growing grass maintained above the channel. The width of the filter strip, measured from the center of the channel, shall be one-half the channel width plus 15 feet (4.5 m).*

### **Construction Specifications**

1. *All trees, brush, stumps, debris, and other obstructions shall be removed and disposed of so as not to interfere with the proper functioning of the diversion.*
2. *The diversion shall be excavated or shaped to line, grade, and cross-section as required to meet the criteria specified here, free of irregularities that will impede flow.*
3. *Fills shall be compacted as needed to prevent unequal settlement that would cause damage in the complete diversion.*
4. *All earth removed and not needed in construction shall be spread or disposed of so that it will not interfere with the functioning of the diversion.*
5. *The permanent stabilization of disturbed areas shall be done in accordance with the applicable standards and specifications in this manual. Permanent stabilization techniques include **PERMANENT SEEDING** and **SODDING** (in **Chapter 4**).*

## 8.13 Check Dam

### Definition

Small dams constructed across a swale or other stormwater conveyance.



### Purpose

To reduce the velocity of concentrated stormwater flows, thus reducing the erosion of a swale or channel. This practice also traps small amounts of sediment generated in the conveyance itself. However, it is not a sediment-trapping practice and should not be used as such.

### Applications

The practice is limited to use in small, open channels that drain 10 acres (4 ha) or less. It should not be used in a live stream. Check dams are especially applicable to sloping sites where the gradient of waterways is close to the maximum for a grass lining.

Specific applications include the following:

1. *In constructed conveyances or swales to facilitate the establishment of a permanent nonerrodible lining, reduce erosion potential, and reduce maintenance.*
2. *In natural conveyances where increased flows are expected as a result of development activities.*

### Construction Specifications

No formal design is required for check dams. They can be used as temporary or permanent structures. Check dams may be designed by an engineer and appear on the stormwater management plan, or they may be installed by the contractor on an "as required" basis. In any case, the following criteria should be adhered to when constructing check dams:

- *The drainage area of the ditch or swale being protected should not exceed 10 acres (4 ha). The maximum height of the check dam should be 2 feet (60 cm).*

The center of the check dam must at least 6 inches (16 cm) lower than the outer edges.

- The maximum spacing between the dams should be such that the toe of the upstream dam is at the same elevation as the top of the downstream dam (see **Figure 8.11**).
- Stone check dams should be constructed of FDOT Aggregate No. 1 to a thickness of 2 to 3 inches (5 to 8 cm) of stone. Hand or mechanical placement is necessary to completely cover the ditch or swale and to ensure that the center of the dam is lower than the edges.

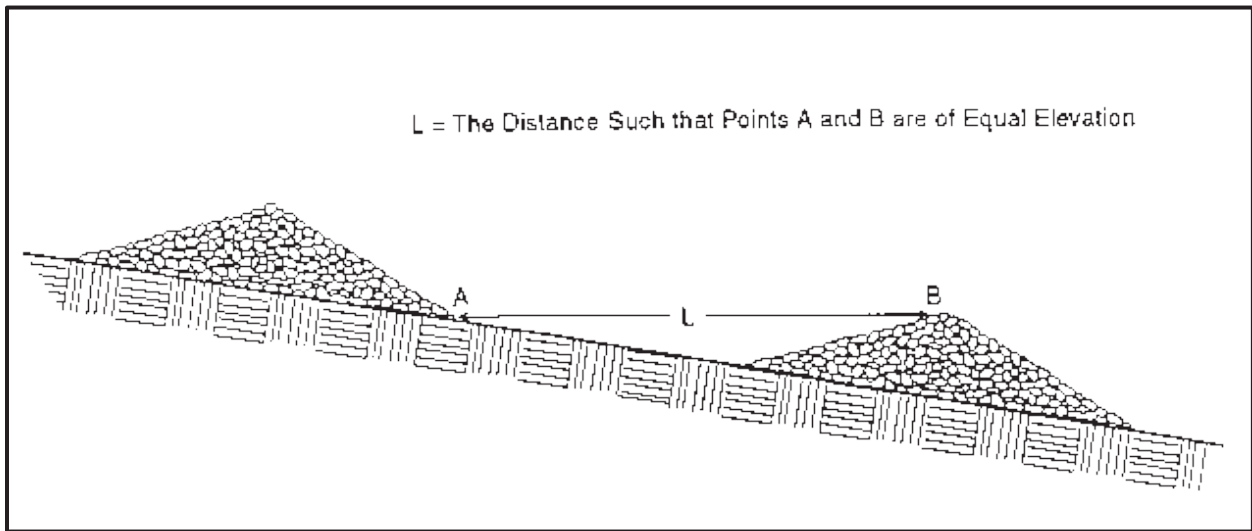

**Figure 8.11. Spacing between check dams**

Source: Virginia DSWC

## 8.14 Outlet Protection

### Definition

Structurally lined aprons or other acceptable energy-dissipating devices placed at the outlets of pipes (see **Figures 8.12a, 8.12b, and 8.12c**) or paved channel sections (see **Figure 8.12d**). The most common types are riprap aprons or concrete aprons with energy dissipator blocks or walls.



### Purposes

To prevent scour at stormwater outlets and to minimize the potential for downstream erosion by reducing the velocity of concentrated stormwater flows.

### Applications

Applicable to the outlets of all pipes and paved channel sections where the velocity of flow at design capacity of the outlet exceeds the permissible velocity of the receiving channel or area.

### Construction Specifications

Subgrade preparation for all types of outlet protection shall follow the guidelines in **EARTHWORK SPECIFICATIONS** (in this chapter). Riprap outlet protection aprons shall be installed in accordance with **RIPRAP** (in this chapter). Underlying geotextiles shall be anchor trenched in at least 6 to 9 inches (15 to 25 cm) and backfilled.

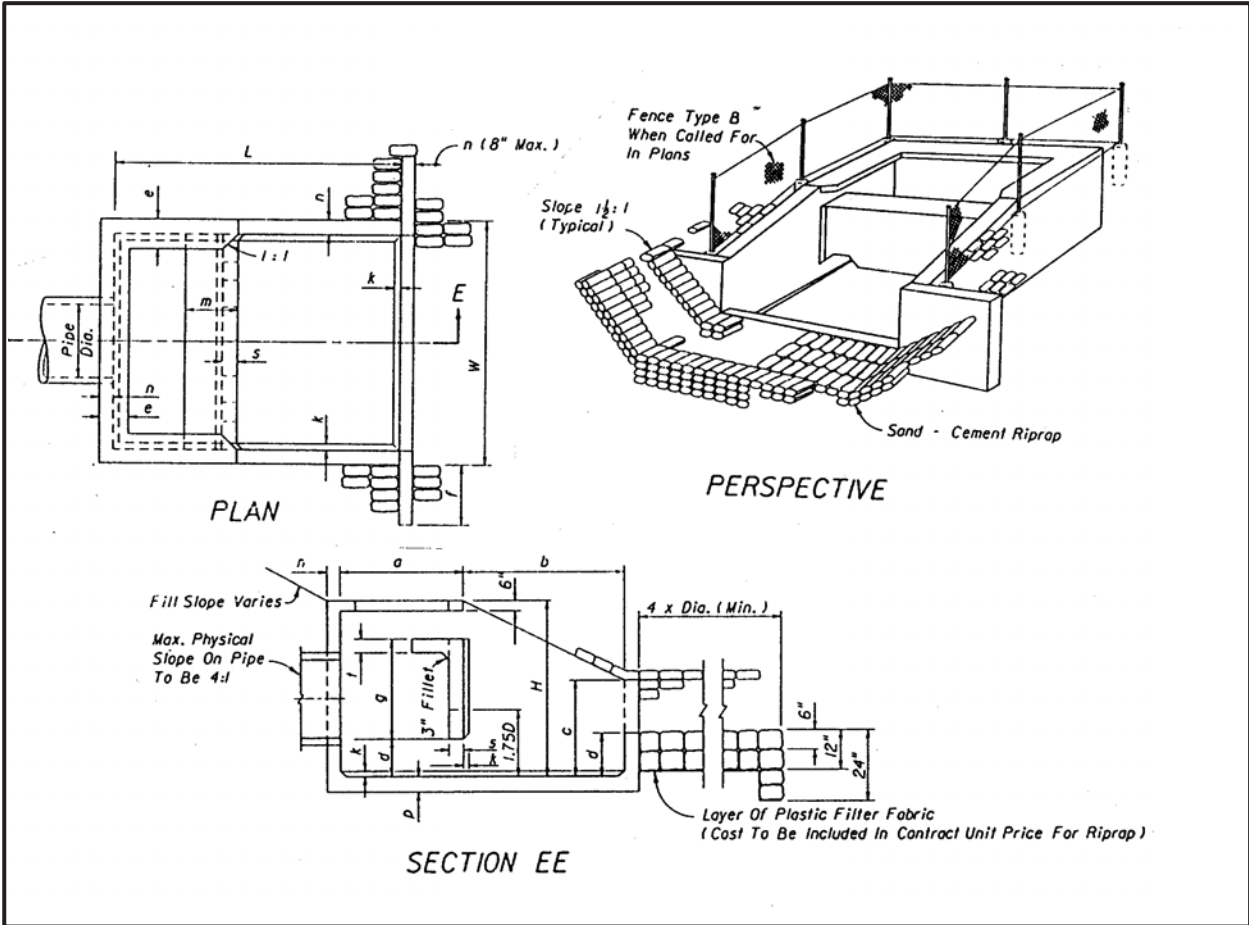
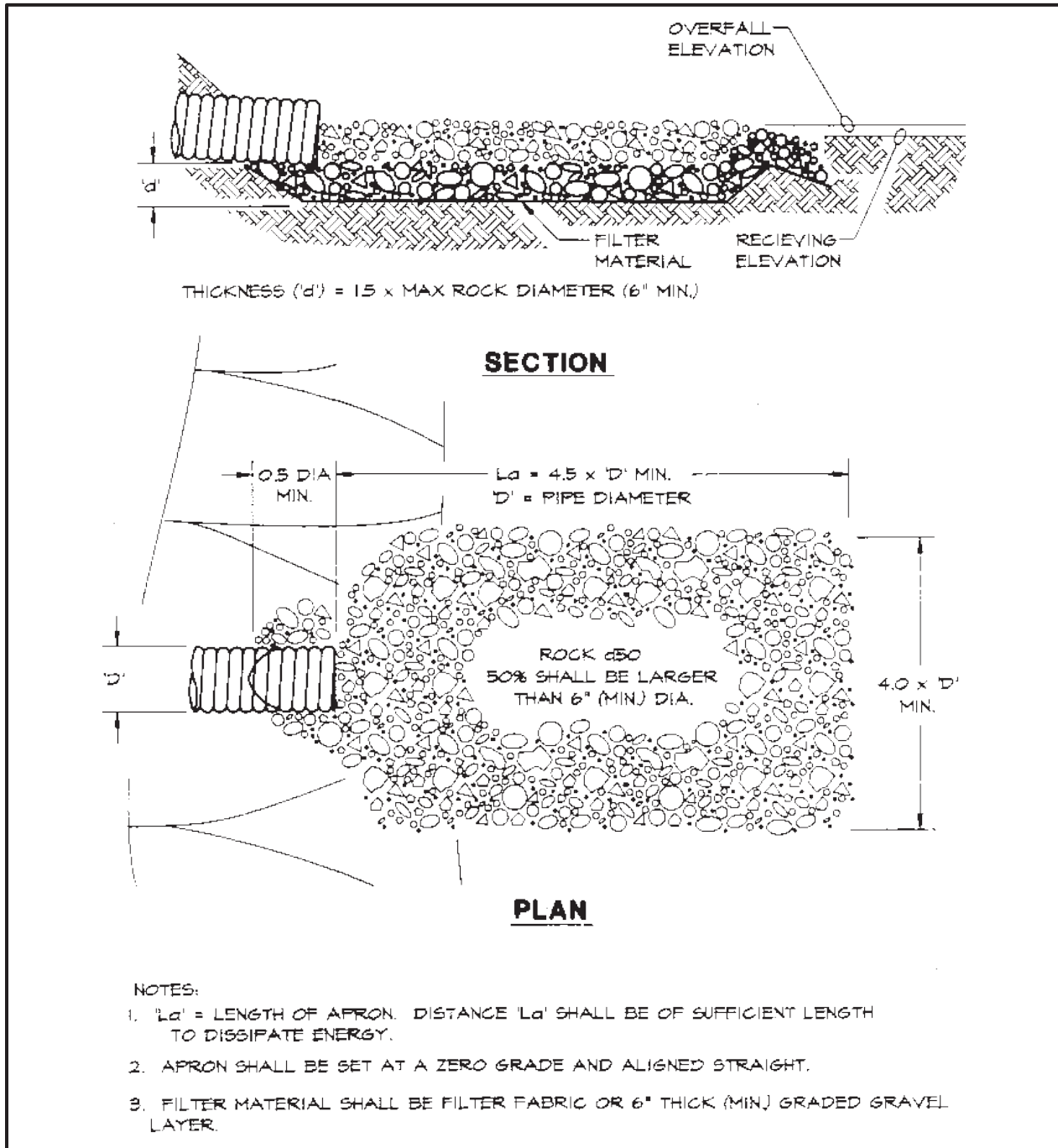

Figure 8.12a. Energy dissipater

Source: FDOT



**Figure 8.12b. Energy dissipater**

Source: Erosion Draw

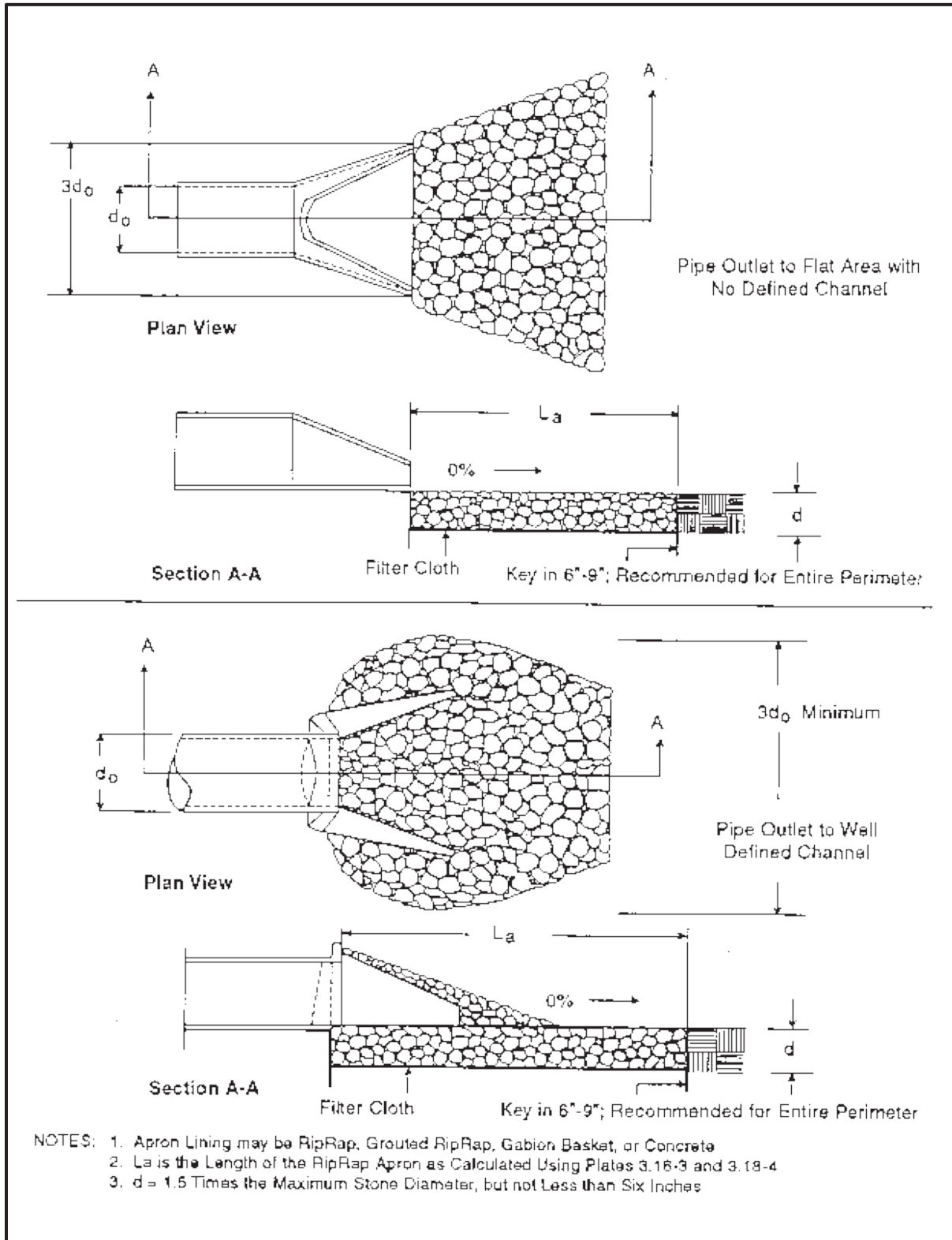

**Figure 8.12c. Pipe outlet conditions**

Source: Virginia DSWC

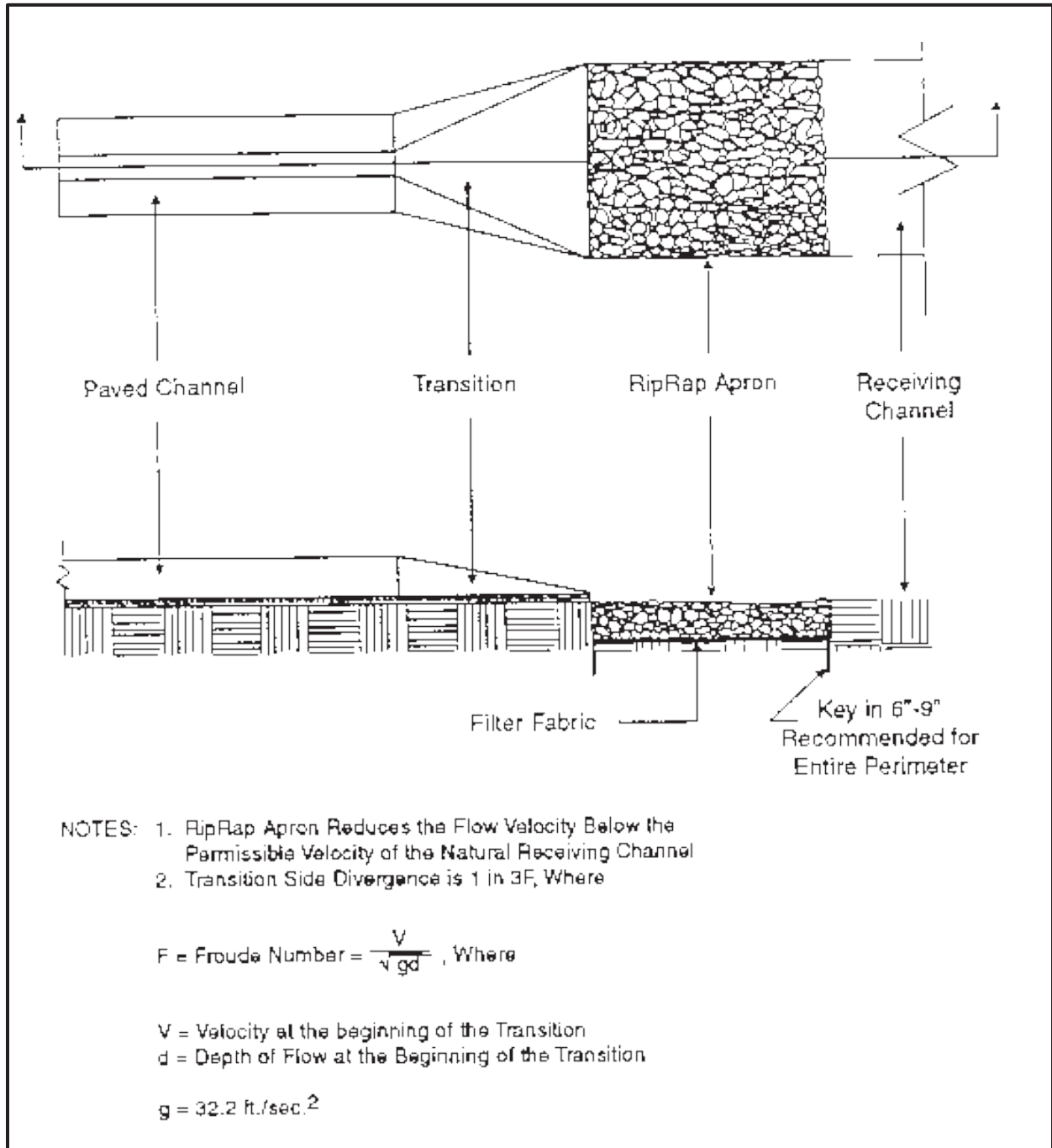

**Figure 8.12d. Paved channel outlet**

Source: Virginia DSWC



## 8.15 Riprap

### Definition

A permanent, erosion-resistant ground cover of large, loose, angular stone.

### Purposes

1. *To protect the soil surface from the erosive forces of concentrated runoff.*
2. *To slow the velocity of concentrated runoff while enhancing the potential for infiltration (see **Figure 8.13a**).*
3. *To stabilize slopes with seepage problems and/or noncohesive soils (see **Figure 8.13b**).*



### Applications

The practice is used for soil–water interfaces where soil conditions, water turbulence and velocity, expected vegetative cover, etc., are such that the soil may erode under the design flow conditions. Riprap may be used, as appropriate, at storm drain outlets; on channel banks and/or bottoms, roadside ditches, and drop structures; at the toes of slopes, etc. (see **Figure 8.13c**).

### Construction Specifications

#### *Subgrade Preparation*

The subgrade for the riprap or filter blanket shall be prepared to the required lines and grades. Any fill required in the subgrade shall be compacted to a density approximating that of the surrounding undisturbed material. Brush, trees, stumps, and other objectionable material shall be removed.

#### *Filter Blanket*

The placement of the filter blanket should be done immediately after slope preparation. For granular filters, the stone should be spread in a uniform layer to the specified depth. Where more than one layer of filter material is used, the layers should be spread so that there is minimal mixing of the layers.

For plastic filter cloths, the cloth should be placed directly on the prepared slope. The edges of the sheets should overlap by at least 12 inches (30 cm). Anchor pins 15 inches (38 cm) long should be spaced every 3 feet (90 cm) along the overlap. The upper and lower ends of the cloth should be buried a minimum of 12 inches (30 cm) deep. Care should be taken not to damage the cloth when placing the riprap. If damage occurs, that sheet should be removed and

replaced. For large stone 12 inches (30 cm) or greater in size, a 4-inch (10 cm) layer of gravel may be necessary to prevent damage to the cloth.

**Stone Placement**

The placement of riprap should immediately follow the placement of the filter. The riprap should be placed so that it produces a dense, well-graded mass of stone with a minimum of voids. The desired distribution of stones throughout the mass may be obtained by selective loading at the quarry, the controlled dumping of successive loads during final placing, or a combination of these methods. The riprap should be placed to its full thickness in one operation, not placed in layers. Stones should not be placed by dumping into chutes or similar methods that are likely to cause segregation of the various stone sizes. Care should be taken not to dislodge the underlying material when placing the stones.

The finished slope should be free of pockets of small stone or clusters of large stones. Hand placing may be necessary to achieve the required grades and a good distribution of stone sizes. The final thickness of the riprap blanket should be within plus or minus one-fourth of the specified thickness.

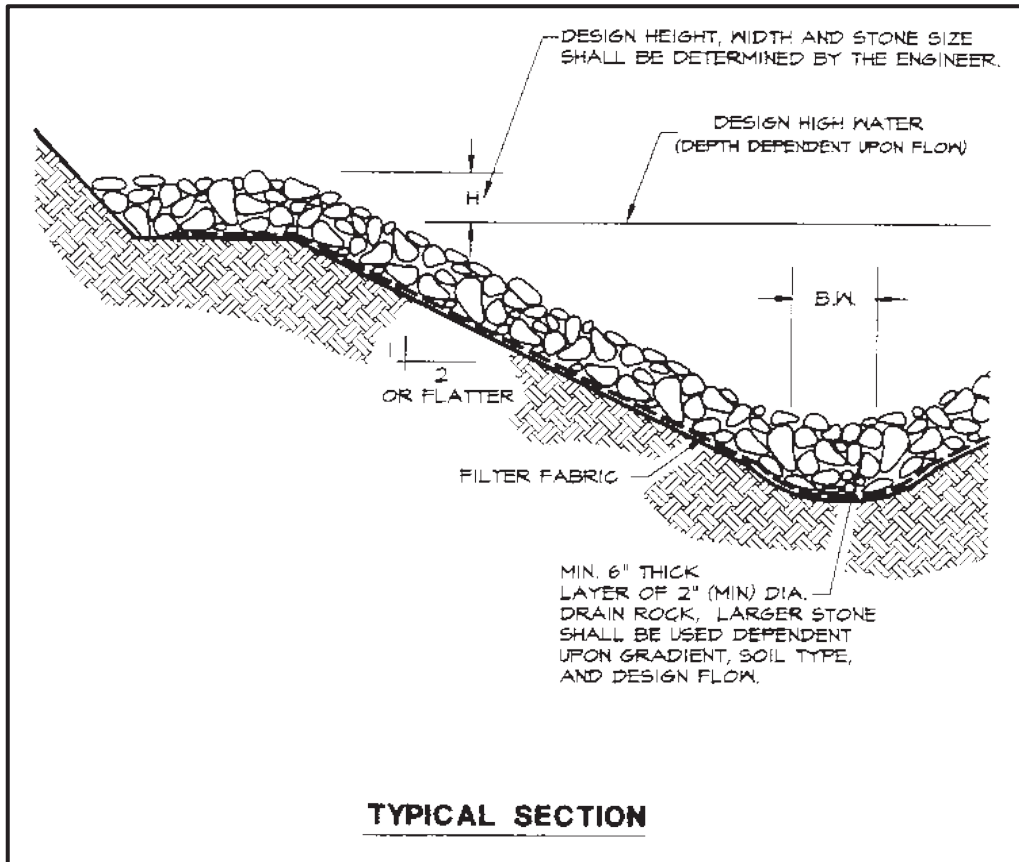

**Figure 8.13a. Rock-lined channel**

Source: Erosion Draw

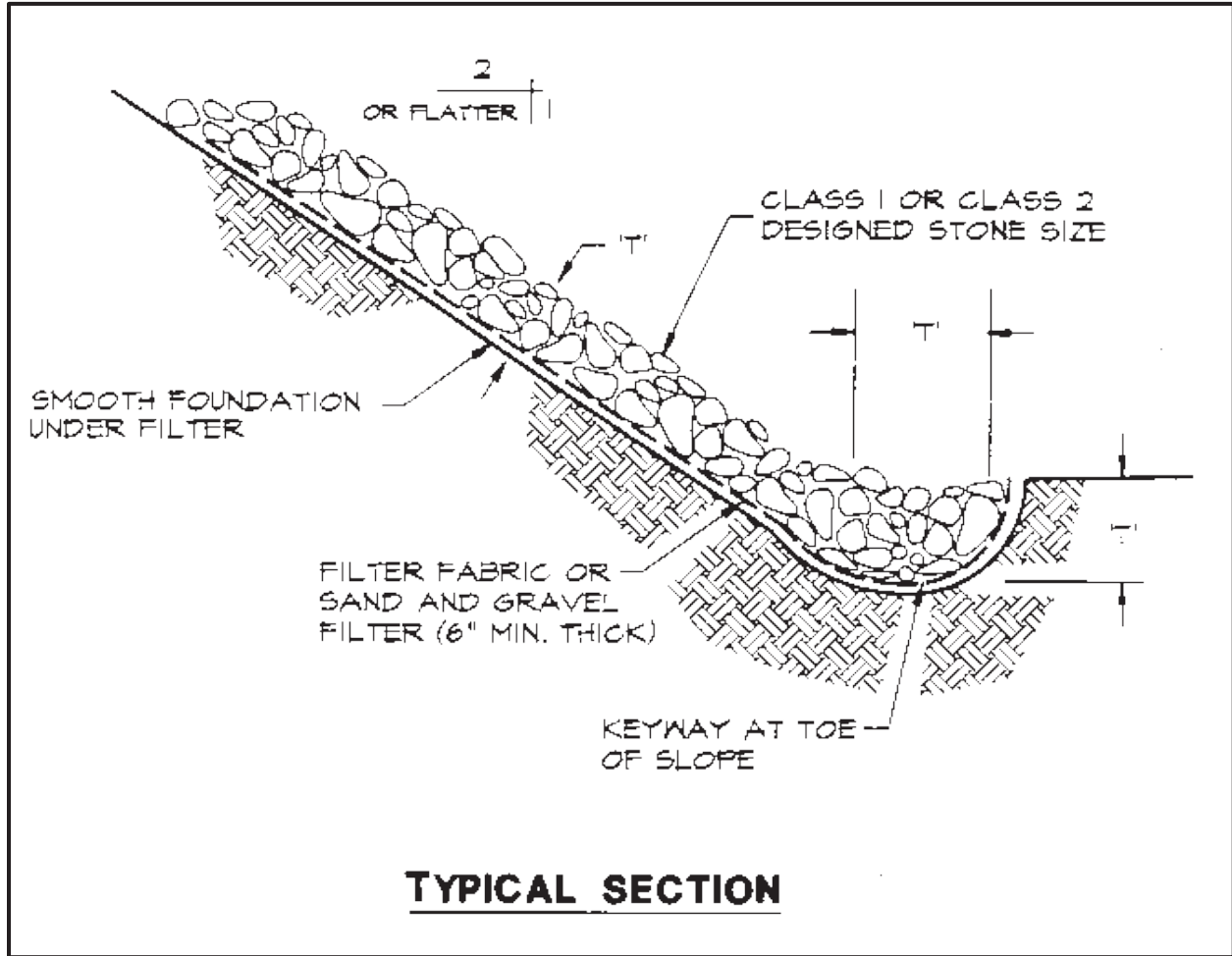
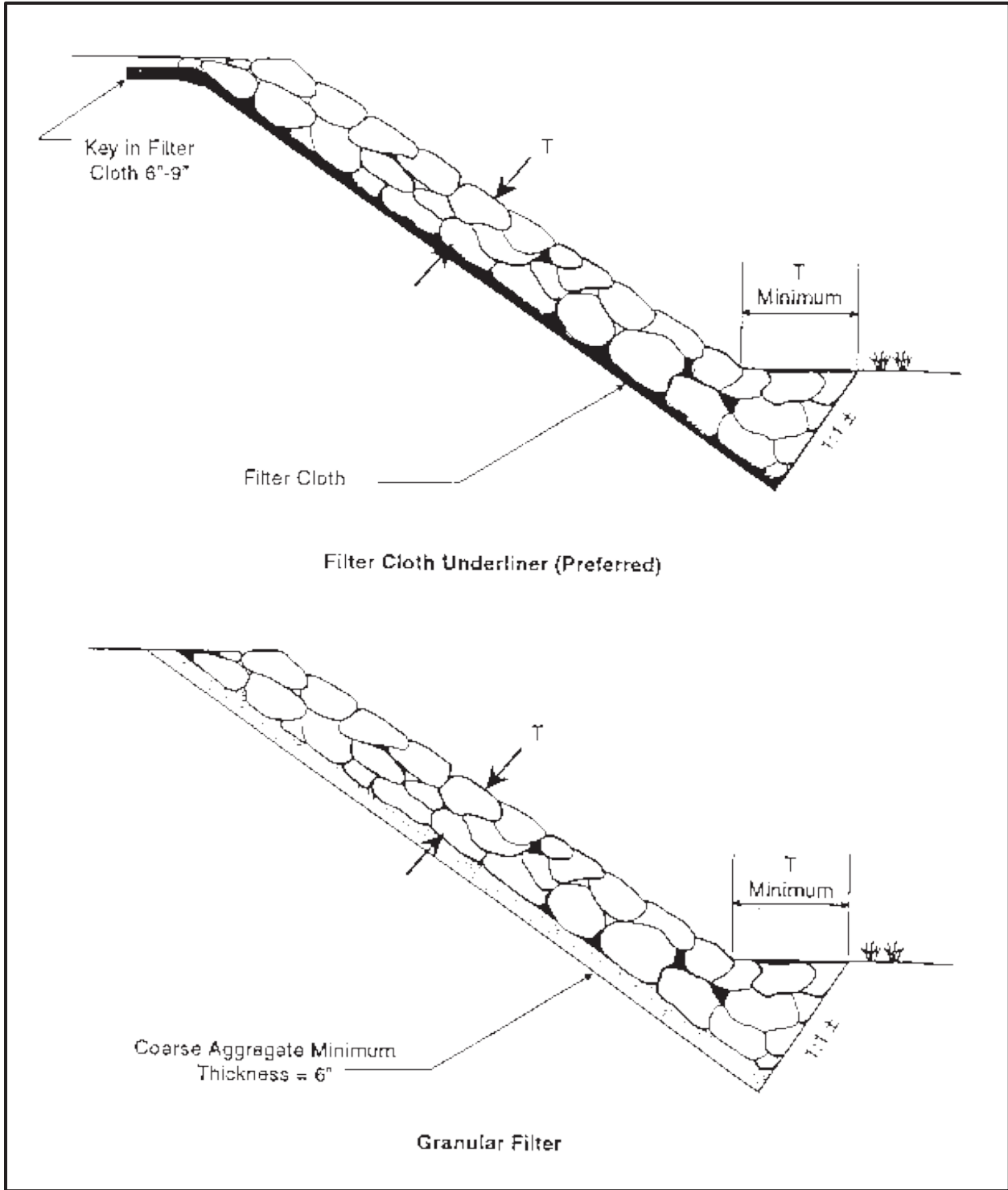

Figure 8.13b. Riprap slope protection

Source: Erosion Draw



**Figure 8.13c. Toe requirements for bank stabilization**

Source: Virginia DH&T

## 8.16 Grid Confinement System

### Definition

A high-density polyethylene (HDPE) grid confinement system stabilizes slopes or stream banks and allows vegetation to establish itself. The geometry of the three-dimensional cells also increases load-bearing capacity (see **Figure 8.14a**).

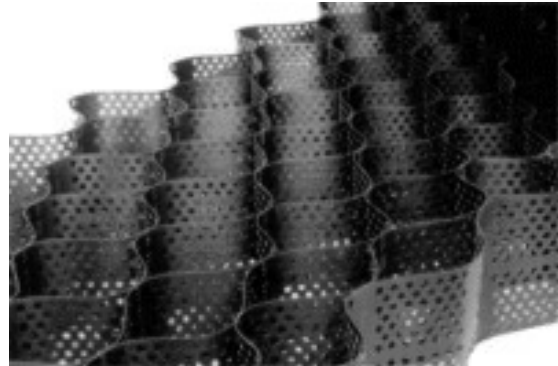

### Purpose

To prevent erosion from relatively steep slopes by the stabilization of the soil surface.

### Applications

1. Disturbed areas that require protection from erosive forces but require the aesthetics of vegetation not provided by rock riprap or continuous concrete lining.
2. Sloping areas with intermittent traffic or other factors that make vegetation hard to establish or maintain (see **Figure 8.14b**).
3. Areas that require a firm surface for mowing with mechanical equipment.
4. Low-volume vehicle use areas, such as overflow parking, utility easements, unpaved roads, and driveways.
5. Grid confinement systems can be stacked to build earth-retaining walls (see **Figure 8.16c**).

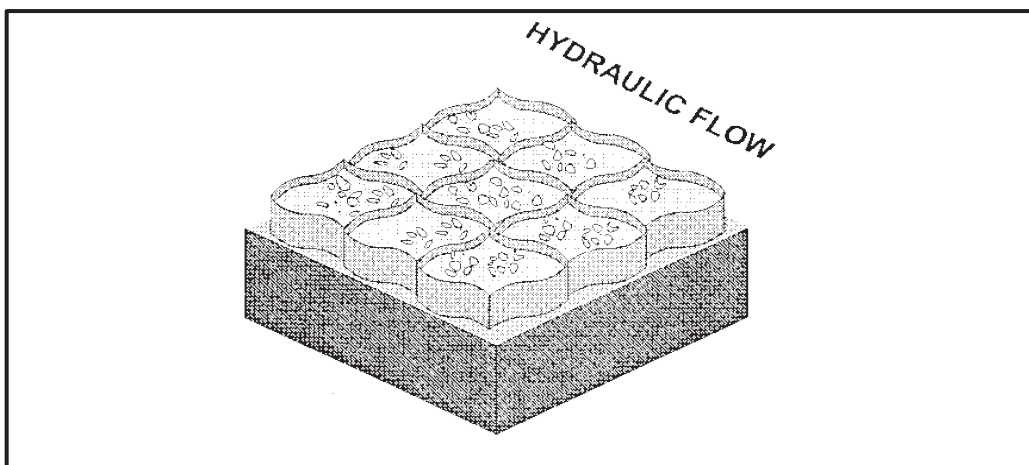

**Figure 8.14a. Grid confinement system**

Source: NRCS

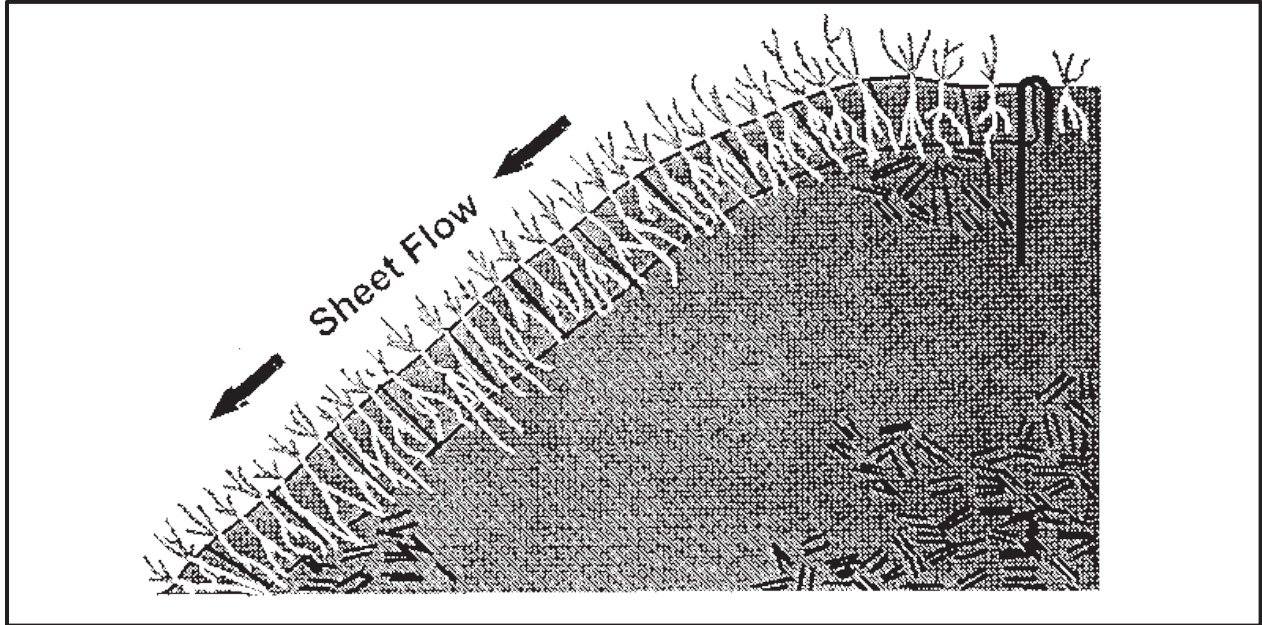

**Figure 8.14b. Vegetative protection**

Source: NRCS

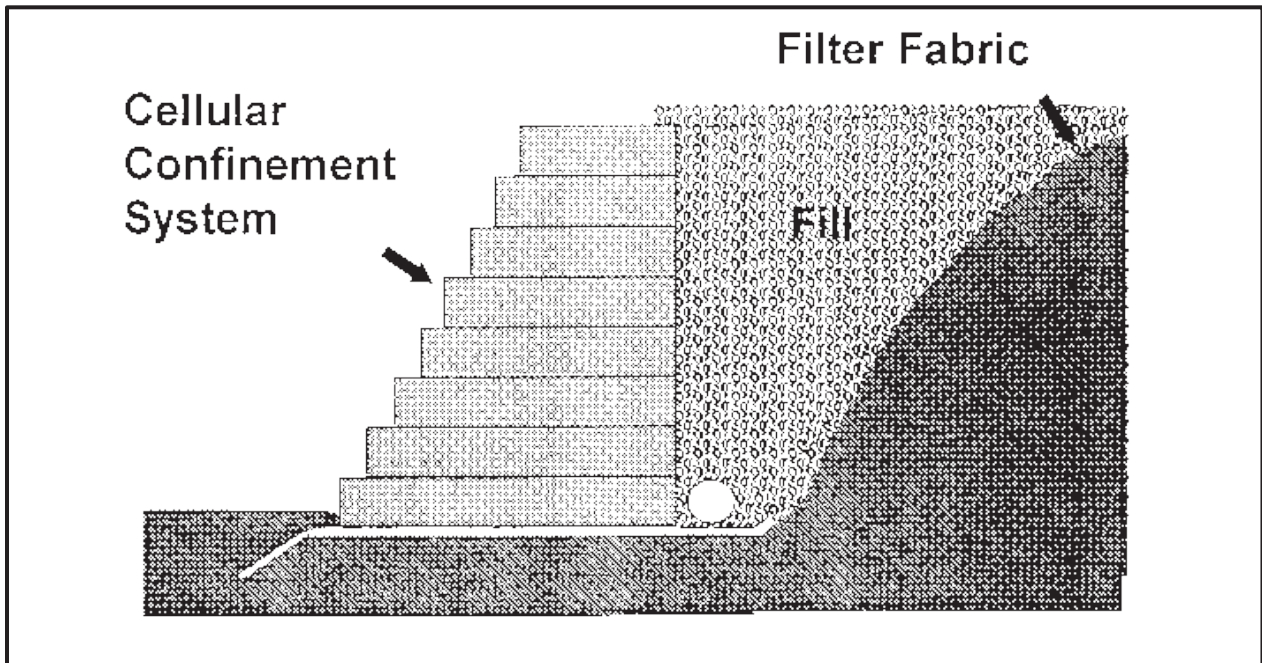

**Figure 8.14c. Gravity-retaining wall**

Source: NRCS

## **Planning Considerations**

Compared with cellular concrete block or rock riprap, grid confinement systems are a less expensive alternative erosion control practice that combines the benefits of vegetative and structural practices. A grid confinement system can be filled with locally available soils, small rocks, or concrete. By stacking layers of grids, retaining wall structures can be created.

**TEMPORARY SEEDING** or **PERMANENT SEEDING** (see **Chapter 4**) may be needed after installation to establish appropriate vegetative cover.

## **Design Criteria**

No formal design is required.

## **Construction Specifications**

### *Geotextile*

Geotextile shall be placed prior to the placement of the grid confinement system. The proper filter fabric to be used should be determined using a sieve analysis of the soil to be protected. After the analysis, a filter fabric is selected that will retain the soil being protected and have openings large enough to permit drainage and prevent clogging.

The strength under tensile stress for the filter fabric should be at least one and one-half times the weight of the blocks. If no backfill material is to be used, the fabric should have good ultraviolet (UV) light stability. Filter fabric should be buried at least 12 inches (30 cm) at the upper end of the protected area to prevent undermining.

### *Placement*

Before the filter fabric is placed, the area to be affected should be prepared so there is minimal disruption of the smooth plane of the slope. The grid confinement system shall be stretched according to the manufacturer's recommendation. The grid may be attached to a preconstructed rack to aid in installation. The grid shall be staked, at a minimum, at least every third cell across the top, bottom, and center of each grid unit, if the unit dimension exceeds 3 feet (90 cm). If the unit's length is less than 3 feet (90 cm), stakes are required at the top and bottom of the grid. Where grids are laid adjacent to each other, the cells shall be locked together using hog rings or an equivalent locking system.

### *Backfill and Vegetation*

Open grids will be backfilled with gravel, crushed stone, or soil. Vegetation provides additional stability at the area above the protective lining by consolidating soil. The area may need to be seeded to accelerate the establishment of vegetation. Seed may be premixed with the fill material to prevent the seed from washing out before germination.

The equipment placing the material shall not travel on top of the confinement grid until cells are filled in. As part of the grid is filled, the equipment may drive on that portion, subject to the manufacturer's recommendations. If the fill is a graded mixture, it shall be placed in a manner to avoid segregation.

## 8.17 Cellular Concrete Block

### Definition

Precast perforated concrete blocks that stabilize slopes or stream banks, but also allow vegetation to establish itself through openings in the block.

### Purposes

1. *To prevent relatively steep slopes from eroding, through the stabilization of the soil surface (see **Figure 8.15a**).*
2. *To protect the banks of streams, lakes, estuaries, and excavated channels against scour (see **Figure 8.15b**).*



### Applications

1. *Disturbed areas that need protection from erosive forces, but that require the aesthetics of vegetation not provided by rock riprap or continuous concrete lining.*
2. *Sloping areas with intermittent traffic or other factors that make vegetation hard to establish or maintain.*
3. *Areas that require a firm surface for mowing with mechanical equipment.*
4. *Land–water interfaces such as shorelines, channel linings, bridge abutments, spillways, boat ramps, and low-water stream crossings.*

### Planning Considerations

Cellular concrete block is an expensive alternative erosion control practice that combines the benefits of both vegetative and structural practices. Blocks may be of the interlocking or nonlocking type and may be interconnected with flexible cable.

Interconnected blocks can be swung into place for ease of underwater installation. These blocks can be used as a temporary installation and later removed and reused.

It may be necessary after installation to provide **TEMPORARY SEEDING** or **PERMANENT SEEDING** (see **Chapter 4**) to establish appropriate vegetative cover.



## Design Criteria

Design standards are currently under development by the International Erosion Control Association (IECA), working with ASTM.

## Construction Specifications

### *Subgrade Preparation*

The slope should be graded to a smooth plane surface to ensure that close contact is achieved between the slope face and the geotextile, and between the geotextile and the bottom of the articulated concrete blocks. All deformities, roots, grade stakes, and stones projecting from the slope face must be removed, and the slope must be regraded. Holes, "pockmarks," slope board teeth marks, footprints, grooves, depressions, or other localized voids should also be removed, filled, and compacted. The slope and slope face should be uniformly compacted to 95 % standard Proctor density.

To ensure a uniform channel cross-section, it is suggested that a grading template be constructed and "dragged" down the channel in front of the shovel crew. The anchor trench at the top of the slope should be uniformly graded to ensure close contact between all articulated blocks and the underlying grade at the transition between the embankment crest and the slope face. Immediately prior to placing the filter fabric and articulated block, the design engineer should inspect and approve the prepared area.

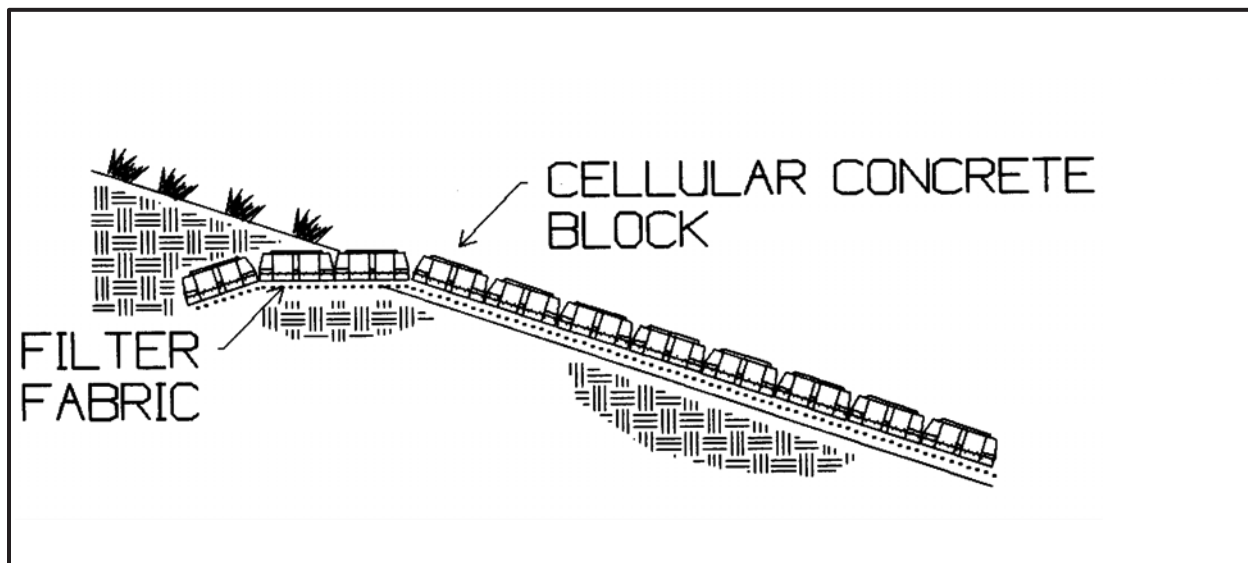

**Figure 8.15a. Slope protection**

Source: R.H. Moore and Associates

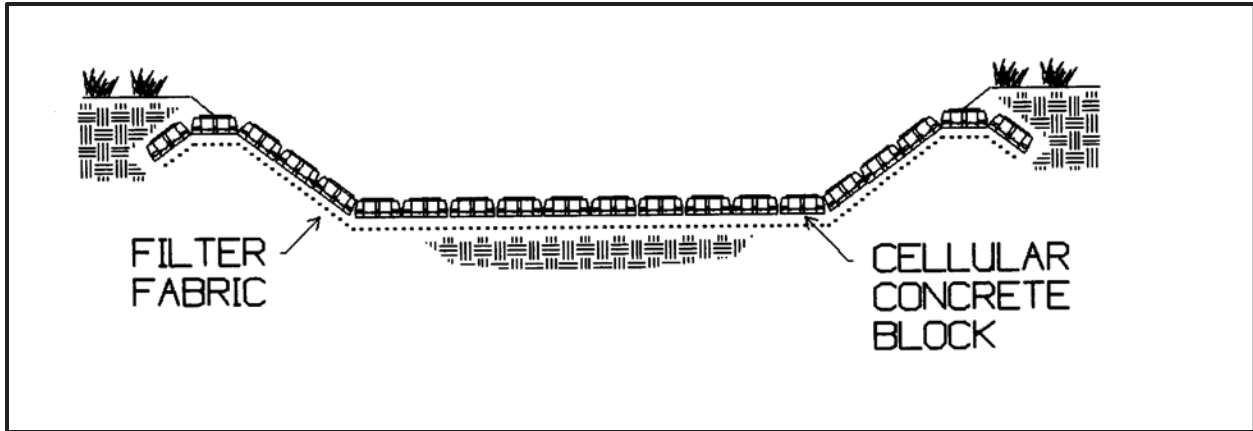

**Figure 8.15b. Channel bottom protection**

Source: R.H. Moore and Associates

### ***Placement of Geotextile***

The geotextile should be placed directly on the prepared area, in close contact with the subgrade, and free of folds or wrinkles. The geotextile should not be walked on or disturbed if it results in the loss of close contact between the articulated block and the geotextile, or between the geotextile and the subgrade. The geotextile should be placed so that the upstream strip of fabric overlaps the downstream strip. The longitudinal and traverse joints should overlap at least 3 feet (1 m). The geotextile should extend at least 1 foot (30 cm) beyond the top and bottom of the revetment. If articulated blocks are assembled and placed as large mattresses, the edge of the geotextile should not occur in the same location as a space between the articulated block mattresses.

### ***Placement of Articulated Block***

The articulated blocks should be placed on the geotextile to produce a smooth plane surface in close contact with the geotextile. No individual block within the plane of placed articulated blocks should protrude more than the design tolerance, typically 1/2 inch (12 mm). To ensure that the articulated blocks are flush and develop close contact with the subgrade, it is suggested that the blocks be "seated in" with a roller or "stepped on" to produce a flush surface.

If assembled and placed as large mattresses, the articulated mats are typically attached to a spreader bar to aid in lifting and placing the mats in their proper position with a crane. The mats should be placed side by side and/or end to end, so that they abut each other. Mat seams or openings between mats greater than 2 inches (5 cm) should be filled with grout.

Whether placed by hand or in large mattresses, distinct grade changes should be accommodated with a transition curve of not less than 4 feet (1.3 m). However, if a discontinuous surface exists in the direction of flow, a grout seam at the grade change location should be provided to produce a continuous, smooth flow surface.

### **Installation Details**

The articulated concrete block system should extend horizontally at the top of an embankment side slope at least 2 feet (0.6 m) into the embankment before terminating. The revetment should be terminated into an anchor trench at least 2 feet (60 cm) deep. The trench should be immediately backfilled, compacted, and protected from erosion that could undermine the system. The top of the anchor trench should remain flush with the top surface of the block system. When flow transition occurs, as in the case of flumes or drop structures, the articulated blocks should extend into the zone of subcritical flow before terminating in an anchor trench.

The termination at the toe of the protected embankment could either be (1) extended outward as an apron a distance of 1.5 times the maximum expected depth of scour, (2) buried to a depth of 1.5 times the maximum depth of scour, or (3) buried with large rocks or other suitable erosion-resistant backfill. When the articulated block system is to be buried, the blocks should continue into the toe trench along the same grade as the slope being protected. Side termination is performed by burying the articulated block into an anchor trench at least 2 feet (60 cm) deep and backfilling with a nonerodable material to the top surface or the adjacent blocks.

### ***Grouting***

When placing blocks at sharp bends, pilings, pipe outlets, slope intersections, and other irregular areas, individual blocks should be cut to fill the area. Concrete grout should be placed in the area where blocks have been cut (see **Figure 8.15c**). Grout should also be placed in any seams or joints greater than 2 inches (5 cm) wide.

### ***Backfill and Vegetation***

Void spaces in the articulated concrete block system may be filled with gravel or crushed stone in areas below the waterline and with soil in areas above the waterline. Do not overfill voids with soil, as the best results are obtained when the soil level is kept 1/2 to 3/4 inch (12 to 18 mm) below the top of the blocks. Typically, 1 cubic yard of material is needed for every 200 square feet of area (1 m<sup>3</sup>/24 m<sup>2</sup>).

Vegetation provides additional stability to the area above the protective lining by consolidating the soil. Seeding may be needed to accelerate the establishment of vegetation. Seed should be premixed with the fill to prevent the seed from washing out before the vegetation is established. Hydroseeding may also be used (see **Figure 8.15d**).

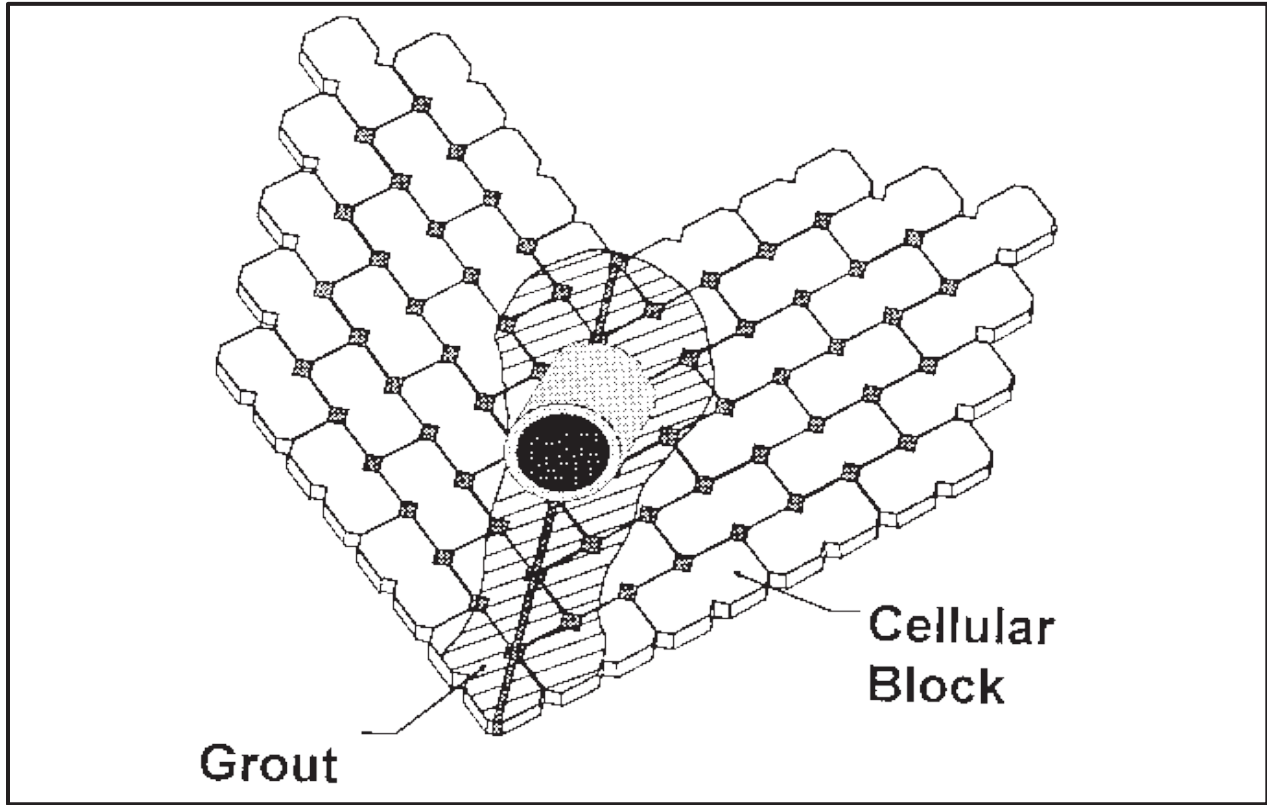

Figure 8.15c. Grout illustration

Source: NRCS

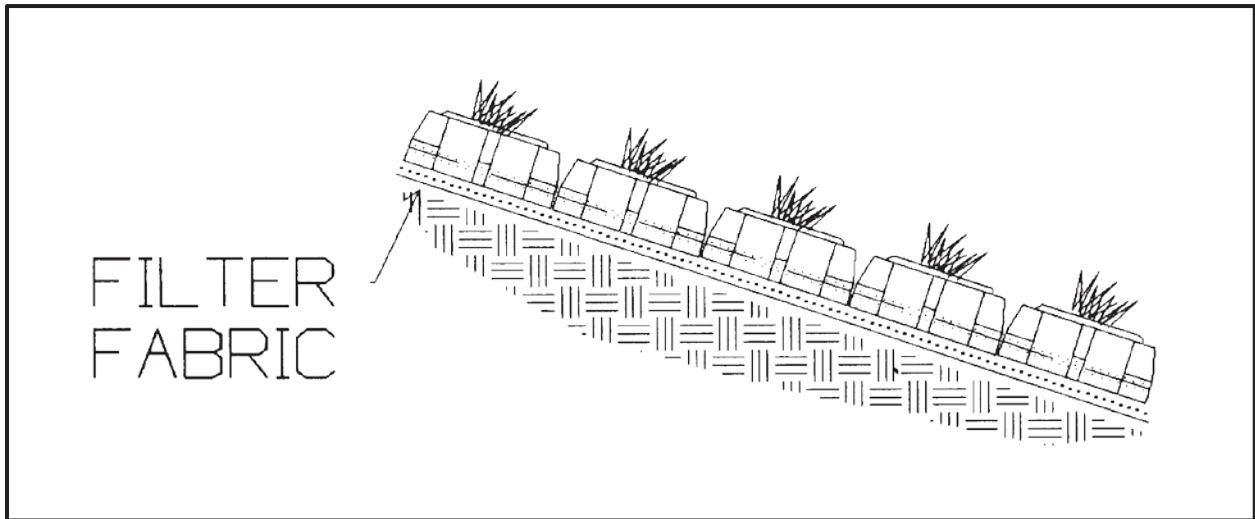

Figure 8.15d. Revegetation

Source: NRCS

## **8.18 Maintenance**

### **8.18.1 General**

Maintenance is of primary importance if stormwater management systems are to continue to function as originally designed. A local government, a designated group such as a homeowners' association, or an individual must accept the responsibility for maintaining the structures and the impoundment area. A set of "as-built" plans should be prepared for and maintained by the responsible entity. A specific maintenance plan should be formulated outlining the schedule and scope of maintenance operations. It should be stressed that good records should be kept on all maintenance operations to help plan future work and identify facilities requiring attention.

### **Inspections**

All stormwater systems should be routinely inspected to ensure that they are functioning properly. Major inspections should be conducted semiannually, and brief inspections should always be conducted following storms with over 1 inch (25 mm) of rainfall.

Systems that incorporate infiltration are especially critical, since poor maintenance practices can soon render them inefficient. It is also advisable to ensure that vegetation (sod) is growing well and that all construction is according to approved design.

### **Safety**

All permanent impoundments and structures should be inspected periodically by a Florida-registered professional engineer to ensure that they remain structurally sound and mechanically efficient. An annual safety inspection is recommended where the potential for downstream damage and loss of life because of impoundment failure is high. Look for signs of burrowing animals, especially on or near embankments. All structures should also be inspected for scour, erosion, settlement, and structural failure following major storms.

Many jurisdictions require fences around impoundments with side slopes of 3:1 or steeper. Fencing, gates, and locks should be inspected quarterly, and a list of key holders should be kept.

### **Public Health**

Precautions should be taken to minimize the production of fast-breeding insects in and around ponded areas. Possible control measures include controlling the growth of vegetation at shorelines, varying the water depth every few days, and stocking the pond with mosquito-eating fish such as *Gambusia*, or mosquito minnow.

## **8.18.2 Maintaining Retention Systems**

### **Stormwater Retention Basins**

**Routine Maintenance.** The cleanout frequency of infiltration basins depends on a number of factors, including whether they are vegetated or nonvegetated, whether pretreatment BMPs are used, and their storage capacity, infiltration characteristics, volume of inflow, and amount and type of sediment load. Infiltration basins should be thoroughly inspected at least semiannually. Sedimentation basins and traps may require more frequent inspections and cleanout. These structures should be cleaned out when sediment levels reduce storage volume by 10 %. An elevation mark (also known as a tattletale) should be located inside the basin.

Nonvegetated basins can be scarified annually following the removal of all accumulated sediments. Rotary tillers or disc harrows with light tractors are recommended for maintaining retention basins. The use of heavy equipment should be discouraged to prevent excessive compaction of surface soils. The basin floor should be left level and smooth after the tilling operation to ease the future removal of sediment and minimize the amount of material to be removed during future cleaning operations. A leveling drag towed behind the equipment on the last pass will accomplish this. However, this operation can be eliminated or minimized by the establishment of grass cover on the basin floor and slopes. The roots of vegetation help maintain soil permeability.

The BMP treatment train, especially sediment traps or forebays, can be used to reduce the maintenance of infiltration basins by settling out suspended solids, or removing oil and grease before the water is released into the infiltration basin.

Infiltration basins should never be used for sediment control during the construction process. In situations with heavy sediment loads, chemical flocculants can also be used to speed up settlement in pretreatment sediment traps or forebay ponds. Flocculants should be added to the runoff water in the settlement pond inlet pipe or culvert, where turbulence will ensure more thorough mixing. After suspended matter has flocculated and settled in the settling pond, the water may then be released into the infiltration basin for disposal.

Algae or bacterial growth can also inhibit infiltration. To avoid this problem, make certain that the basin dries out between storms, especially during the wet summer months.

### **Exfiltration Trenches**

Preventive maintenance is vital to the continued effectiveness of all infiltration BMPs, but especially for exfiltration systems. Pretreatment measures to filter out suspended materials that might clog the trench are necessary, because once void areas become clogged, maintenance entails a complete replacement of the filter material. The use of filter fabrics over the surface of an infiltration trench that is open to the surface for runoff can be most effective in keeping objectionable material from entering the system. Of course, periodic cleaning or replacement of clogged filter fabric will be necessary.

**Routine Maintenance.** The routine maintenance requirements of trenches are not great. However, getting property owners to actually perform routine maintenance may be very difficult. Trenches are smaller and more inconspicuous than most other BMPs, and when located underground, they may not be visible or accessible. As a result, residents or homeowners' associations are not as likely to exhibit as much concern over trench maintenance as they might for more visible BMPs, such as detention ponds.

For these reasons, a public sector commitment to regularly inspect privately owned trenches is a necessity. Property owners and associations will need to be educated about the function and maintenance requirements of the trench. A legally binding maintenance agreement should be included with the property deed that clearly describes maintenance tasks and schedules. Further, the agreement should grant access for regular inspections, and enable the public sector to perform maintenance (and bill the owners) if the trench has been neglected. Some of the normal maintenance tasks for trenches are detailed below.

**Inspection.** The trench should be inspected several times in the first year of operation and at least semiannually thereafter. The inspections should be conducted after large storms to check for surface ponding that might indicate local or widespread clogging. Water levels in the observation well should be recorded over several days to check trench drainage. Surface trenches can be inspected by hand by digging with a trowel down to the first layer of filter fabric, usually located 1 foot (30 cm) below the surface.

**Buffer Maintenance.** The condition of the grass buffer strips used in conjunction with trenches should be inspected regularly (see **SODDING** in **Chapter 4** for further information on buffer maintenance).

**Sediment Removal.** The pretreatment inlets of underground trenches should be checked periodically and cleaned out when sediment depletes more than 10 % of the available capacity. This can be done manually or by a vacuum pump. Inlet and outlet pipes should be checked for clogging and vandalism.

**Nonroutine Maintenance.** The primary nonroutine maintenance task is to rehabilitate the trench after it becomes clogged. There is no reliable estimate of how long trenches will function before they clog. However, the longevity of trenches may be on the order of 10 years at best.

Clogging in surface trenches is most likely to occur near the top of the trench, between the upper layer of stone and the protective layer of filter fabric. Surface clogging can be relieved by carefully removing the top layer of stone, removing the clogged filter fabric, installing new filter fabric, and cleaning or replacing the top stone layer. The costs for rehabilitating a surface trench will usually not exceed 20 % of the initial construction cost, adjusted for inflation.

The clogging of underground trenches is a much more serious problem, as it is likely to occur at the bottom of the trench, at the filter fabric/soil interface. The rehabilitation of an underground trench requires removing the pavement or the topsoil/vegetation layer, the protective plastic

layer, the stone aggregate, and the bottom filter fabric layer. Then, the subsoil layer must be tilled to promote better infiltration, and each layer must be replaced. If pavement or concrete constitute the surface layer (instead of topsoil/grass), the rehabilitation effort becomes more difficult and costly.

**Total Maintenance Costs.** No reliable data are currently available to assess maintenance costs for trenches. Routine maintenance costs are probably higher for surface trenches than underground trenches, primarily because the former must be carried out more often. As noted earlier, the opposite is probably true for nonroutine maintenance tasks. It is reasonable to assume that the cost of rehabilitating an underground trench is roughly equivalent to the initial construction cost. Surface trench rehabilitation should be approximately 20 % of the initial construction cost; however, there are reasons to expect that the clogging of surface trenches may occur more frequently.

If it is assumed that surface and underground trenches will need rehabilitation every 5 to 15 years, respectively, an annual maintenance set-aside of 5 % to 10 % (surface trenches) and 10 % to 15 % (underground trenches) of the initial construction cost may be needed to cover routine/nonroutine maintenance expenditures. It must be emphasized that these estimates are highly uncertain. Until more local experience is obtained, the issue of trench maintenance costs remains largely speculative.

### **Porous Pavement**

**Routine Maintenance.** Routine maintenance involves the removal of debris too coarse to be washed through the pavement system. Vacuuming pavements is required to remove particulates that are fine enough to be carried into the pavement but too large to pass through, thus clogging the void space. Porous pavements require no more repair maintenance than conventional pavements, and thus maintenance problems can generally be reduced to better "housekeeping" practices on the part of area residents and more efficient street-cleaning procedures in municipalities.

To preserve the high filtration rate of the pervious paving, routine inspection and maintenance are required. The surface should be routinely visually checked (preferably after a prolonged storm event) for evidence of debris, ponding of water, clogging of pores, and other damage. Any debris should be immediately removed. Monthly cleaning with a vacuum street sweeper should be performed to thoroughly clean the surface.

**Cleaning.** It has long been recognized that the maintenance and cleaning of porous pavements to prevent or alleviate clogging is a factor in the use of such pavements. Various methods have been used to clean sections of porous pavement that have become clogged.

However, no satisfactory method has been found for cleaning fully clogged pavements, and only a superficially clogged section showing a water penetration rate of 1/10 inch (2.5 mm) per second compared with a normal water penetration of 1/3 inch (10 mm) per second can be restored to



normal operation. The best method for cleaning is brush and vacuum sweeping, followed by high-pressure water washing of the pavement.

Vacuum cleaning alone, once the pavement is clogged, is largely ineffective. The oils bind dirt, and only an abrading and washing technique is effective in its removal. Clogging to a depth of 1/2 inch (13 mm) is sufficient to prevent water penetration.

If, during visual inspection, any ponding or clogging is noticed, the following steps should be taken to correct the problem. First, a street sweeper with a vacuum should be used. If ponding persists, the pavement can be steam cleaned with a biodegradable substance and then vacuumed. If the clogging is at a depth greater than 1/2 inch (13 mm), holes that are 1/4 inch (6.5 mm) in diameter and 1 foot (30 cm) on center can be drilled through concrete pavement. Hand-held drills or truck-mounted drill rigs may be used. All drilling debris should be vacuumed from the pavement.

**Replacing Clogged Pavement.** Once a large area of porous pavement is fully clogged and cannot be adequately cleaned, the paving must be removed to a depth where the clogging is not evident and new porous paving filled in. In extreme cases, the affected area must be removed and new topping put down. Since these materials are relatively new, obtaining a patching mix suitable to match the installed pavement may be difficult. Available patching material is usually dense graded at present. If the sub-base becomes clogged, the pavement must also be saw cut and removed. Six to 12 inches (15 to 30 cm) of the sub-base usually needs to be replaced with clean sand and then proof rolled. Pervious paving then needs to be filled in.

### **Concrete Grid and Modular Pavement**

Where turf is incorporated into these installations, normal turf maintenance—watering, fertilizing, and mowing—is necessary. Mowing is seldom required in high-traffic areas. It is documented that the hard surfaces in these installations require very little maintenance. However, fertilizers, pesticides, and other chemicals may have adverse effects on concrete products. The use of such chemicals should be restricted as much as possible.

### **Grassed Waterways and Swales**

Timely maintenance is important to keep a swale in good working condition. Fertilizing and mowing should be done frequently enough to keep the vegetation in vigorous condition. The cut vegetation should be removed to prevent the decaying organic litter from adding pollutants to the discharge from the swale.

Vehicular traffic should be excluded from the swale. Following heavy rainfall, always inspect the area for failures and carry out necessary repairs, replacements, or reseeded during the planting season. If complete reseeded is necessary, apply half the original recommended rate of fertilizer with a full rate of seed.

Many residents find swales to be convenient sites for the disposal of leaf litter, grass clippings, and other types of refuse. Additionally, these yard materials have been found throughout Florida

to contribute to the impairment of our local streams, lakes, and rivers. Many communities have started enforcing ordinances with citations and/or fines to stop residents from disposing of their yard waste in swales and stormwater conveyances. The proper operation of these facilities from both a hydraulic and treatment standpoint depends on the integrity and knowledge of the residents whom the system serves. The actions of a few careless individuals can cause an outlet to become plugged with debris, leading to the delivery of abnormally high levels of organic material to downstream waters, and sometimes the flooding of a neighbor's property. Public education programs should be undertaken, as necessary, to ensure that swales are not used as trash disposal areas. DEP has published a pamphlet entitled [Save the Swales](#) to educate citizens.<sup>10</sup>

### **Special Operations and Maintenance Conditions for Karst-Sensitive Areas**

In areas of active sinkhole activity, a site inspection should be performed by field personnel when the retention basin is excavated to final grade. The objective is to visually inspect for exposed limerock or solution pipes. To mitigate the potential for direct connections from onsite infiltration basins to groundwater, the following activities are recommended:

- 1. Stormwater swales and retention basins should be monitored visually following significant storm events. If open solutions or pipes and/or sinkholelike depressions are observed, this information should be relayed to permitting authorities, and appropriate corrective action should be taken.*
- 2. Where small, shallow depressions are noted, these may be filled to pre-existing grade with clayey sand materials, graded, and vegetated.*
- 3. When and if chimney-type solution pipes are exposed in a retention basin, these may be plugged in accordance with acceptable water well plugging and abandonment procedures. Where these features are small in diameter and of a limited vertical depth, the bridging of the pipe with indigenous limestone boulders is recommended. Once the bridge is in place, the pipe may be filled with clay and/or clayey sand back to the land surface and then vegetated.*
- 4. Remedial plugging activities should employ methodologies acceptable to the applicable regulatory agency.*

### **8.18.3 Maintaining Detention Systems**

#### **Stormwater Detention Basins**

The maintenance of sediment and debris basins is extremely important. Plans should include provisions for sediment removal when a certain storage elevation is reached. Debris removal in

---

<sup>10</sup> <http://www.dep.state.fl.us/water/nonpoint/docs/nonpoint/sts.pdf>

detention basins can be achieved through the use of trash racks or other screening devices. Debris should be removed from the basin following each storm.

**Sediment.** Sediment deposition should be continually monitored in the basin. The maintenance plan should specify an elevation at which the sediment should be removed. This elevation mark or tattletale should be located inside the basin. The mark should be set at no more than 25 % of capacity; however, 10 % is preferred.

Owners, operators, and maintenance authorities should be aware that significant concentrations of heavy metals (e.g., lead, zinc, and cadmium), as well as some organics such as pesticides, are expected to accumulate at the bottom of these treatment facilities. Sediment should be tested using an extraction procedure (EP) toxicity test, especially near points of inflow, to determine the leaching potential and level of accumulation of hazardous material before disposal via land spreading or filling is prescribed.

### **Underdrains and Filters**

Like all stormwater BMPs, a properly designed and constructed underdrain filter system requires maintenance to keep it operating. The underdrains should be inspected, especially after heavy rains, to see if they are working and if maintenance is required. Pore spaces in stormwater filters are expected to seal with time once the filters begin operating. The duration of a filter's effectiveness before hydraulic capacity is reduced to the point that drawdown requirements can no longer be met depends on a number of factors, including the initial permeability of the filter material used, the degree of pretreatment (sedimentation) before stormwater enters the filtration facility, and the nature of the pollutants being removed. Common causes of subsurface filter system failures include the following:

1. *Underdrains installed with insufficient capacity.*
2. *Underdrains located too shallowly and a lack of auxiliary structures necessary for the installation.*
3. *Underdrains of insufficient strength or lacking in other qualities necessary for the installation.*
4. *Poor construction, resulting in inadequacies such as the poor connection of joints and fittings, improper bedding, poor grade and alignment, and improper backfilling.*
5. *Failure because of mineral deposits such as iron oxide. These deposits do not seriously affect the operation of the drain unless the perforations or joints become sealed. Usually, indications of deposits may be observed at the outlets, junction boxes, and inspection holes.*

**Surface Maintenance.** Vegetated basins can be mowed and maintained in accordance with **Chapter 4**. The surface layers of unvegetated basins may need to be plowed or scraped following heavy storm events that carry heavy sediment loads. Preliminary indications show that these systems can often function for up to a year with only minor maintenance.

**Filter Maintenance.** Coarse-grained filter systems may require the complete replacement of the filter media to restore their function following clogging, since pollutants penetrate farther into these systems than in more fine-grained filters. Most of the particulates are trapped in the first 2 or 3 inches (5 to 8 cm) of the fine-grained filter, while suspended substances can penetrate up to 1 foot (30 cm) or more into the coarse-grained filter.

Semiannual restoration efforts are likely to involve the complete removal and cleaning and/or replacement of the top 12 inches (30 cm) or more of the filter material. While major maintenance of this type may not have to be done frequently, when it is required, the operation involves a significant amount of labor and material. Heavy machinery may be needed if the facility is large, and therefore care is needed to prevent damage to the underdrain pipes. There may be some problems associated with the ability of these more coarse-grained, evenly graded materials to support the machinery needed to perform maintenance activities, such as scraping, without getting equipment stuck and/or damaging the filter bed.

**Pipe Network Maintenance.** The roots of nearby trees and shrubs will penetrate and clog perforated pipe, if they are near enough. If an underdrain system is not functioning and the outlet is open, the lines should be checked near trees. Obstructions caused by roots can be cleared by a Roto-Rooter-type machine; however, this service will be required several times per year until the source of root penetration is eliminated. High-pressure hydraulic nozzles have been successfully used to clean underdrain filter systems in Florida that show evidence of iron oxide.

**NOTE:** This segment does not constitute a product or service endorsement.

Another common maintenance problem with underdrains in Florida is getting landowners to keep the outlets free of silt and vegetation where they empty into open ditches. Sediment and fast-growing aquatic vegetation can cause the outlets to become entirely plugged within one year after installation; consequently, frequent inspections must be made.

#### ***8.18.4 Maintaining Conveyance Systems***

##### **Stormwater Conveyance Channels**

**Grass-Lined Channels.** During the initial establishment, grass-lined channels should be repaired immediately and grass re-established if necessary. After grass has become established, the channel should be checked periodically to determine if the grass is staying in place. If the channel is to be mowed, it should be done in a manner that will not damage the grass.

**Concrete-Lined Channels.** Concrete-lined channels should be checked periodically to ensure that there is no undermining of the channel. Particular attention should be paid to the outlet of the

channel. If scour is occurring at the outlet, appropriate energy dissipation measures shall be taken.

**Sediment Deposition.** If the channel is below a high sediment-producing area, sediment should be trapped before it enters the channel. If sediment is deposited in grass-lined channels, it should be removed promptly to prevent damage to the grass. Sediment deposited in riprap and concrete-lined channels should be removed when it reduces the capacity of the channel. The photos below show three conveyance channels, each requiring regular maintenance.



Grass-lined channel



Paved or concrete channel



Flexamat or reticulated concrete channel

### **Diversions**

Before final stabilization, a diversion should be inspected after every rainfall. Sediment shall be removed from the ditch line and repairs made as necessary. Seeded areas that fail to establish a vegetative cover shall be reseeded as necessary.

### **Flexible Channel Liners: Riprap, Gabions, Grid Confinement Systems, and Cellular Blocks**

Once a flexible channel liner installation has been completed, it should require very little maintenance. It should, however, be inspected periodically to determine if high flows have caused scour beneath the riprap or dislodged any of the stone or block. If repairs are needed, they should be carried out immediately. The repair should be stronger than the area that failed, and may therefore require grout, concrete, or larger stones.

Many of these systems are designed to incorporate vegetation. Desirable vegetation (turf) should be regularly mowed. Large weeds, shrubs, and trees should be controlled so that roots do not cause premature failure of the system.

## ***8.18.5 Maintaining Stormwater Management Structures***

### **Paved Flumes**

Before the permanent stabilization of a slope, the structure should be inspected after each rainfall, and damage to the slope or paved flume should be repaired immediately. After the slope is stabilized, little maintenance should be required. During periodic inspections, look for bypassing or undermining of the entrance and resulting erosion along the sides. Also check the bottom for scour beyond the apron or energy dissipators and remove any debris in the energy dissipators.

### **Check Dams**

Check dams should be checked for sediment accumulation after each significant rainfall. Sediment should be removed when it reaches one-fourth of the original height or before. Regular inspections should be made to ensure that the center of the dam is lower than the edges. Erosion caused by high flows around the edges of the dam should be corrected immediately. If stone check dams are used in grass-lined channels, care must be taken to retrieve any stone that washes downstream.

### **Waterway Drop Structures**

Once the waterway drop structure is constructed and the area around it stabilized, maintenance should be minimal. During routine inspection, however, the channel should be checked for scour above and below the structure. The embankment should be checked to ensure that vegetation is well-established. The structure itself should be checked for cracking of the concrete, uneven settlement, and piping around the structure.

### **Outlet Protection**

Outlets should be inspected after every major storm. Outlet pipes should be in sound structural condition and free of sediment accumulation. Energy dissipators, splash pads, and riprap aprons should be kept free of debris. Look for scour below the outlet.

Wherever such erosion is detected, effective measures should be taken quickly to stabilize and protect the affected area.

### **Other Stormwater Management Structures**

**Inlets.** Pipe inlets should be inspected for clogging and/or structural integrity after each major storm, and accumulated debris and sediment should be removed as required. Trash racks should be cleaned and should be replaced if missing.

**Control Structures.** In addition to inlets and outlets, many stormwater management facilities have control structures to regulate the rate and/or water level in the facility. These structures must be inspected frequently for sediment and debris. Control structures should be checked annually by the design engineer for structural integrity.

## ***8.18.6 Maintaining Vegetation***

### **Turf**

Turf is used for erosion protection, water treatment, velocity reduction, and aesthetics. Regular mowing and occasional fertilization are required to maintain desired growth. Avoid cutting turf too short; this may damage the plant, reduce the desirable friction in channels, and reduce the protection to soil. A lack of mowing can lead to invasion by weeds. In areas that impound or convey stormwater, clippings should be bagged and removed to reduce the organic loading.

### **Trees and Shrubs**

Trees and shrubs have a place in stormwater management systems, in places such as wet detention facilities. However, there are many areas where trees and shrubs **are not desirable!** Trees and shrubs should be kept off dam and emergency spillway areas. Should these plants die, their large, decaying root systems can seriously reduce the structural integrity of an embankment.

In addition, trees that start to grow in the vicinity of an exfiltration trench or an underdrain system should be removed immediately. This helps to avoid root puncture of the filter fabric through which sediment might enter the structure. When practical, fallen leaves should be removed from stormwater conveyance or impoundment areas.

# Chapter 9: Inspection and Enforcement

- 9.1 Introduction
- 9.2 The Role of the Inspector
  - 9.2.1 Conduct
  - 9.2.2 Compliance
  - 9.2.3 Handling Violations
- 9.3 Site Inspection
  - 9.3.1 The Inspection
  - 9.3.2 Tolerances
  - 9.3.3 Preparing for an Inspection
  - 9.3.4 Preconstruction Conference
  - 9.3.5 Before You Leave the Office
  - 9.3.6 Inspecting the Site
  - 9.3.7 Causes of Noncompliance
  - 9.3.8 Inspection Reports
- 9.4 Regulatory Agencies

\*\*\*\*\*

## 9.1 Introduction

The specific duties and responsibilities of the inspector depend in part on the employing agency or company; however, many of these duties and responsibilities are common to all inspectors. This chapter describes the essential tasks carried out by all inspectors. There is no substitute for on-the-job training from experienced inspectors or supervisors, as well as a broad understanding of associated environmental issues.

## 9.2 The Role of the Inspector

The material in this section is intended primarily for inspectors employed by regulatory agencies. Except for enforcement issues, most of the material also applies to inspectors working for private firms. Private inspectors may also be called on to monitor and document other matters, such as costs, schedule adherence, the consumption of supplies, and program implementation.

### 9.2.1 Conduct

The inspector must have technical expertise in erosion prevention and sediment control. Knowledge of other programs such as the state's wetlands permitting/ERP programs is helpful. Effective communication and people skills also are an asset to a field inspector. The inspector must remember that the goal of a compliance inspection is to evaluate the performance of the sediment and erosion control practices at a construction site in an unbiased manner. Regulated receiving waters must be protected to the maximum extent practicable during construction activities. If the site is not achieving compliance, then the inspector or regulatory agency may offer potential solutions and recommendations to achieve compliance. No matter what the situation, inspectors need to carry out their responsibilities in a professional manner and in



accordance with the rules. Inspectors must be consistent in their inspections, handling all sites, individuals, problems, and violations equally.

In dealing with the public, it is essential to follow proper legal procedures and to remain professional, courteous, and fair to encourage mutual respect at job sites. Regulatory agencies as well as private companies typically have standard operating procedures defined for the inspectors to follow during inspections. For further details on enforcement procedures and legal policies/procedures, an inspector should contact the appropriate Office of General Counsel or legal division.

### **9.2.2 Compliance**

Remember that the goal of the permitting program is to prevent accelerated erosion and offsite (receiving water) sedimentation, as well as associated pollution that may be mobilized by the processes of erosion and sedimentation. As the inspector, you are the first person to determine if the performance standards and intent of the erosion and sediment control rules are being met. You are the key person ensuring that construction sites are evaluated according to the permit conditions and that the responsible party is notified regarding site compliance.

The erosion and sediment control rules are performance oriented. That is, the measures used at a construction site **must be effective in controlling erosion and preventing sedimentation from reaching a regulated receiving water for the site to be in compliance**. Following an approved plan and installing the control measures may not be enough for a site to be in compliance. The responsible authority must ensure that additional measures are installed to correct problems and may have to correct/mitigate any adverse environmental impacts that occur. The erosion control plan may also need to be updated to reflect changes in site conditions and BMPs.

The rules are flexible, allowing the responsible parties to decide the most economical and effective means for erosion control. This encourages the use of innovative techniques and specifically designed erosion control systems. As the first person to recognize performance failures and report problems, the inspector is a key individual in making these kinds of performance-based rules work. The inspector's job is as follows:

- 1. Determine that an erosion and sediment control plan for the site has been developed and approved, where applicable.*
- 2. Determine that all specified practices have been installed and are being fully and properly maintained.*
- 3. Determine that offsite sedimentation and turbidity in receiving waters are being prevented.*

If the inspector finds deficiencies, then the responsible authority should be contacted immediately for appropriate action to be taken to attain compliance expeditiously.

### **9.2.3 Handling Violations**

As the inspector of the site, you play a central role in providing details of violations and subsequent corrections. The inspection records that you write could be the basis for enforcement and administrative/civil penalties and could be used for potential criminal actions. Inspectors are often called on to appear at enforcement meetings or hearings as witnesses to document a violation. Conversely, an accurate enforcement case can serve to refute a suspected violation.

**You should write a report for every site inspection.** When writing your inspection report, remember that it is a legal document and may be public record. Your report must be written legibly, accurately, consistently, and in clear and concise language. Most important, it should only contain defensible facts and not hearsay or opinion. Report all violations observed each time you visit a site, even if you have reported some of them on previous visits. **Always write inspection reports while you are on the site** so that you will not forget items and can recheck conditions if you have doubts. Field notes also can be effective in meetings. They should be organized, thorough, concise, and legible.

Make a habit of taking organized, well-written notes. It will pay off if you are involved in an enforcement case or need to offer solutions to a particular problem.

The private inspector must also document activities thoroughly and accurately. This is the client's best defense in the event of a violation. Good documentation shows whether the client is a "habitual offender" or a conscientious professional who has been overwhelmed by unusual events, often an important factor in determining a resolution.

## **9.3 Site Inspection**

Inspections don't "just happen." A great deal of planning and preparation goes into a proper and thorough inspection. Inspectors need to review construction plans, attend preconstruction conferences, and be knowledgeable about the law and standards.

### **9.3.1 The Inspection**

An erosion control plan is designed to minimize erosion, control sedimentation, and address other potential sources of pollution. However, some components of the plan may fail, or the responsible party may not adhere to the plan. As an inspector of construction sites, your job is as follows:

- 1. To be certain that all erosion and sediment control measures and other BMPs in the approved plan have been properly installed and maintained.*
- 2. That erosion is being controlled.*
- 3. That offsite sedimentation is being prevented.*
- 4. That no turbidity is being generated in receiving waters.*

It takes time to learn how to inspect a construction site properly. Project sites are often large and can have many land-disturbing activities occurring at the same time, which can be confusing. Also, there are many considerations to keep in mind while conducting an inspection. You must be familiar with the rules and with many different erosion and sedimentation control practices. With some experience, however, you will soon feel comfortable about making an official erosion control inspection.

A proper inspection requires planning and a systematic approach. With careful preparation, you can carry out your duty and work cooperatively with all responsible parties so that those involved can do their jobs efficiently and effectively. Remember, the ultimate goal is to protect water quality.

### ***9.3.2 Tolerances***

The inspector must be reasonable regarding dimensional and performance criteria while performing inspections. This requires an understanding of the intended function of various BMPs. Obviously, a catch basin with an opening designed to support a grate has a zero tolerance for being too small because the grate will not fit. If the opening is one-half inch too wide, the grate will fit and still be supported by the sill or lip. If the opening is two inches too wide, the grate will fall in. This dimensional tolerance can be described as "half-inch plus, zero minus."

A stormwater pond is often designed with 1 foot (30 cm) of freeboard over the riser or spillway. High spots or slightly low spots in the bottom of the pond probably will not affect the performance of the pond. On the other hand, it is critical that the lip of a level spreader is installed "perfectly" level. In this situation, high or low spots will both have the effect of producing concentrated flows. Thus, there is almost zero tolerance, plus or minus.

Other situations are not as simple to define. The potential for impacts and allowable (minor) amounts of mud tracked, or dust generated from a site, may be somewhat subjective. Many factors are involved in determining performance tolerances, such as the severity and frequency of infractions, efforts by the contractors, and the limitations of the technology and products available, etc. However, tolerances are determined, it is essential to the integrity of the inspector and the agency that they are applied consistently and impartially. It should be noted that "convenience" is not considered a limiting factor.

### ***9.3.3 Preparing for an Inspection***

The first step in inspecting a project is to review the plans when first submitted. This alerts you to potential problems at the site and weaknesses in the design of the erosion and sedimentation control system. While at your office, look for the following items in the plan (there are other items that you may want to include as you gain more experience):

- 1. Check contour maps and available aerial photos to see how the water flows through the site. Note where water enters and leaves the site. Determine the direction of flow, the watershed where the project is located, and the receiving*

- water(s).
2. *Note critical or sensitive areas, such as a wetland, stream, conservation easement, pipe outlets, extreme slopes, etc., that may border the site. These areas must be well-protected from impacts.*
  3. *Look for adequate access and space to maintain erosion and sediment control measures during and after construction.*
  4. *Make sure that the plan provides an installation sequence for the construction of BMPs, with measures for one phase being installed before the grading of the next phase begins.*
  5. *Study the construction schedule to determine whether there are long periods between phases of construction. If so, temporary seeding or other temporary soil stabilization may be required.*
  6. *Check to make sure that the plan requires all surfaces to be stabilized as soon as possible after the completion of the project and within seven working days. The plan should state the preferred stabilization method.*
  7. *Ensure that all potential discharge points (wetland boundaries, stormwater management system outfall structures, MS4s, construction entrances, etc.) are protected with sufficient BMPs to prevent pollutants from entering and impacting receiving waters. It may be also beneficial to divert runoff entering from adjacent property around highly erodible areas during construction.*
  8. *Make sure that maintenance plans are adequate and that the contractor's performance-monitoring procedures are specified. For example, it should be specified clearly whether the general contractor, subcontractor, or construction manager is to do the inspection and maintenance.*
  9. *Note any proposed borrow, stockpile, and waste storage areas on the plans and indicate which BMP will be used.*
  10. *Make a list of specific items in the plan that you want to inspect closely when visiting the site. Highlight potential problem areas before leaving the office.*
  11. *Reviewing the erosion and sedimentation control plan should provide you with a solid grasp of the proposed project. From the review, you can identify parts of the erosion control system that may need to be strengthened and parts that should be watched carefully to see if the performance requirement is met. Your experience in the field and in a particular geographic area provides valuable assistance in the approval or revision of the submitted plan.*

The ability to read aerial photos is important because some construction projects now draw the construction plans on aerial photos. It takes some practice to be able to recognize ordinary objects from the air.

Many experienced people have found that aerial photos and topographic maps can help greatly in determining the effects of a project on the surrounding area. Aerial photos can be obtained from FDOT. The 1:660 scale generally is used. The U.S. Geological Survey (USGS) is a good source for topographic maps. These are drawn on a scale of 1:24,000. Also, DEP's [Open Data website](#) provides a portal for a geographic information system (GIS)–based program to obtain a plethora of vital information.<sup>11</sup>

Reviewing the construction plan provides information needed for the next step of the inspection process, the preconstruction conference. Use the suggestions below to ensure that you are fully prepared for the conference.

### ***9.3.4 Preconstruction Conference***

A preconstruction conference is one of the most valuable vehicles through which you can address and avoid potential erosion and sedimentation problems, as well as environmental impacts. It provides you with an opportunity to meet face-to-face with the responsible authority and the contractors. In this way, you can establish the expectations for the project and start a good working relationship with the involved parties.

During the conference, keep the following suggestions in mind:

- 1. Clarify the objectives of erosion and sediment control and inform all parties of the specific requirements for compliance in the project. Also, discuss the inspection procedures and schedule for major earth-moving activities.*
- 2. Ask the responsible authority to designate a contact person for communicating compliance issues and concerns.*
- 3. Be sure that all parties receive/view a copy of the approved erosion and sediment control plan.*
- 4. Inform the responsible authority and contractors that the program is performance oriented and that the plan may need to be updated during the course of construction. Inform all parties about procedures for changing the plans.*
- 5. Try to hold the conference onsite so the group can walk the site. Evaluate the plans to determine whether the measures are appropriate, are located properly, and can be maintained once installed.*

---

<sup>11</sup> <http://geodata.dep.state.fl.us/>

6. *Discuss the schedule for clearing and grading. Emphasize that sediment control measures should be installed before the actual grading begins, in order to capture sediment as it is generated. Be sure that the schedule allows for stabilizing surfaces with temporary and permanent measures between phases of grading and construction.*
7. *Discuss the maintenance requirements so that the responsible authority and contractors know who is responsible for inspecting, cleaning, and repairing the erosion and sediment control measures. Regular inspection and maintenance may need to be supplemented with extra work if a large storm is forecast, or if there are cleanup activities after a large storm, or even if there is a higher-than-normal amount of site activity.*
8. *Establish open communications at the preconstruction conference; this provides a good foundation for your relationship with the responsible authority during the project.*

### **9.3.5 Before You Leave the Office**

The following suggestions are important before you leave the office for the construction site:

1. *Take the time to review the plans thoroughly before you go to the site, even if you have already reviewed them when they were first submitted.*
2. *Outline your approach for each inspection. It is necessary to know in detail the erosion control system specified.*
3. *Always take a copy of the approved plans with you to the site for quick referral (unless they are already onsite).*
4. *Always bring the project file and necessary reporting forms.*
5. *Always take equipment for measuring (level, tape measure, turbidity sampling kit, etc.) and documenting (camera, camcorder).*
6. *Be sure to have all necessary personal protection equipment with you, such as boots, hard hat, sun and insect protection, rain gear, water, first-aid kit, radio, etc.*

### **9.3.6 Inspecting the Site**

At the construction site, ask yourself the following eight questions:

1. *Does this project have an approved permit and is it posted as required by the CGP?*
2. *Is the erosion and sediment control system installed as shown on the approved*

*plans?*

3. *Is erosion being controlled onsite?*
4. *Is sediment being contained onsite?*
5. *Is potential turbidity in receiving waters being prevented?*
6. *Are inspections being recorded and available for review?*
7. *Are previous noncompliance issues and maintenance activities addressed within seven days of their occurrence?*
8. *Are other potential sources of pollution being controlled?*

If the answer to **ALL** of these questions is YES, then the site is in compliance. File an inspection report stating that the site is in compliance and take field notes to support the inspection report. It is a good idea to keep track of the sites where the erosion and sedimentation control plans work well, so that you can show other examples of good sites.

If the answer to **ANY** of the above questions is NO, then the site is not in compliance. File an inspection report listing the items that are not in compliance. Your field notes should describe precisely each noncompliance issue and its location. Remember that others may need to use your field notes, so make them readable and understandable. The following points will help you in checking for compliance:

1. *Carry a set of the approved plans to the site for your reference. They are necessary to determine what measures make up the erosion control system and how they are to be installed and maintained.*
2. *Take detailed, orderly field notes as you do the inspection. Be sure that your notes are neat, concise, and complete (remember, they may be needed as evidence in court).*
3. *Check in with the job superintendent when you arrive so that the contractor knows who you are and what you are doing.*
4. *Walk the perimeter of the site. This gives you a good idea of the terrain and alerts you to any problems with offsite water and sedimentation.*
5. *You may want to start your inspection from the lowest point and work your way upstream through the stormwater management system/site. This helps to make you aware of the amount of sediment leaving the site and can help you locate its source.*
6. *If sediment is flowing offsite, go far enough downstream to see the extent of the damage. In these situations, it is important to document the damage. Estimate*

- the sediment volume. Photos and videotapes make good evidence. Be sure to write the time, date, and other items in your notes and on the inspection report. If other sites are contributing to downstream impacts, make sure to document these as well.*
- 7. If turbidity is present in nearby waters, sampling upstream and downstream of the discharge point can provide the best possible evidence that the site is in or out of compliance. It is the responsibility of the inspector to always check point sources on a job site, where discharges from a recent rainfall event may be discharging offsite into an adjacent wetlands or waters of the state. It is important for an inspector to check turbidity and pH upstream to the discharge, at the discharge point, and downstream to the discharge. Turbidity over 29 NTUs or 0 NTU above the background of an OFW or a high or low pH usually indicates a problem from erosion and sedimentation coming from this discharge point. The inspector should immediately check uphill to this discharge and isolate the noncompliance be it turbidity or pH.*
  - 8. Bring the necessary tools to measure the devices and disturbed areas in the field. Be sure that basins and traps are sized according to the plans, that channels and diversions have the proper grade, and that contributing areas for the control devices are no larger than those specified in the design.*
  - 9. Pay particular attention to the maintenance of erosion and sediment control measures. All measures require regular maintenance and may require special attention after severe storms.*
  - 10. Keep in mind that when certain structural measures fail from improper installation or maintenance, more offsite sediment damage may occur than if the device had not been installed.*
  - 11. Always fill out an inspection report for each trip to a site while you are at the site. The pertinent inspection points are fresh in your mind and you can recheck items that may be in question.*

### **9.3.7 Causes of Noncompliance**

When you find a site that is not in compliance, it is important to determine why. By determining the cause(s), solutions become more apparent. Erosion and sediment control problems on sites generally fall into the following four categories:

- 1. The responsible party has made little or no effort to comply.*
- 2. There are design errors in the erosion control system or the site conditions have changed.*
- 3. The installation or maintenance of a measure is faulty or inadequate.*



4. *Severe weather has occurred.*

**1. The responsible party has made little or no effort to comply.**

Noncompliance is normally easy to identify. The responsible party may believe that the project does not come under the jurisdiction of the rule or may intentionally disregard the provisions of the rule. Quite often these sites are found by inspectors while driving by. Therefore, be observant in your territory.

Once you have found a noncomplying site, inform the responsible authority that compliance is mandatory. On the inspection report, note that the responsible authority has been informed of the law and list the items that are not in compliance. Appropriate enforcement action should be taken. The following are some of the causes of noncompliance in this category:

1. *Failure to apply for a permit or submit a plan.*
2. *Failure to follow the approved plan.*

**2. There are design errors in the erosion control system or the site conditions have changed.**

Noncompliance and failures may occur because the design was inadequate or the site conditions have changed since the plan was prepared. In this event, the plan needs to be revised and approved. The inspection report should note all items of noncompliance and the need for a revised plan.

Compare the original design with conditions in the field. Look for changes in the site conditions and construction plan. Ask yourself the following questions when checking for noncompliance caused by design errors and changes:

1. *Are the planned measures retaining the sediment onsite?*
2. *Are there modifications to the plan?*
3. *Are ground covers adequate for the slope and orientation of the areas to be protected? Is the slope too steep for the ground cover chosen?*
4. *Is the perimeter protected, given the conditions at the site?*
5. *Have the contributing drainage areas changed significantly, thus potentially overloading the control measures? Are additional control measures needed?*
6. *Is the maintenance plan adequate for the existing conditions?*

Again, appropriate enforcement action should be taken.

### **3. The installation or maintenance of a measure is faulty or inadequate.**

Most noncompliance occurs because measures were not installed correctly or maintained properly. Determining the reasons that the measures are failing requires technical knowledge about the devices and how to construct them properly.

### **4. Severe weather has occurred.**

Occasionally, a meteorological event or a series of events that cannot be planned for results in noncompliance. These types of issues must be handled carefully. For example, if a site receives more than six inches of rain in each of three separate storm events over a period of a week or two, there is a good chance that the BMPs used will have at least partially failed. Another example is a tropical system, which can produce well over a foot of rain. These types of mitigating circumstances must be taken into account using the following two guidelines:

1. *If the storm event was predicted, did the site take all "reasonable" steps to minimize any potential adverse environmental impacts?*
2. *Regardless of whether the storm was predicted, what steps did the site take to address and mitigate the impacts to return the site to compliance, and how quickly did they take these steps?*

Remember when evaluating a noncompliance issue or violation to also adhere to the established procedures and policies of your agency and to take into account whether a violation was caused by ignorance, belligerence, or other reasons.

#### ***9.3.8 Inspection Reports***

Inspection reports can have many different formats, styles, and looks. However, the most important aspect to designing or using an inspection report is making sure that it addresses all of the requirements of your jurisdiction. Some inspection reports only address physical issues, while others also handle administrative issues. In general, though, it is recommended that whatever report form you use, adhere to the following procedures so that you have a clearly worded, defensible, and usable product:

- *Document all findings on the inspection forms:*
  - Forms should be filled out completely with no blank spaces. If something is not applicable (N/A), then indicate N/A. If something was not checked, indicate N/C. There should be no blank cells. Your inspection form becomes part of the site's (or your office's) administrative record, so make it accurate, detailed, impartial, and defensible.
  - A Notes/Comments section is suggested so you can expand on some items that may be performance based but that are not permit compliance issues. For example, "It is recommended that subcontractors not be allowed to park on the lots, as it causes more dirt to be tracked into the road." While this is not a permit-related compliance item, it is a good suggestion that can be offered.
  - Make sure that the inspection date is indicated.

- Make sure to indicate what type of inspection this is: Initial, Follow-up, Weekly, After Rain Event, Monthly, etc.
- *Only indicate facts on the inspection report, not opinions.*
- *A signed hard copy of the report should be left at every inspection site if possible.*
- *Let your site contact know that you have completed your inspection. At the very least, make sure to debrief them on all noncompliance issues.*
- *Understand that the construction site, the SWPPP, and the inspections do not occur in a vacuum. There needs to be dynamic interaction between all of these elements for full compliance to be achieved.*

## 9.4 Regulatory Agencies

Multiple levels of regulatory oversight are associated with erosion and sediment control. The following list, while not fully inclusive, briefly describes many of these agencies and their jurisdictions:

1. ***U.S. Environmental Protection Agency (EPA)*** – Oversees the federal wetlands program and the NPDES Stormwater Program.
2. ***U.S. Army Corps of Engineers (USACE)*** – Has jurisdiction over the permitting of the federal wetlands program, Section 404 of the federal Clean Water Act, and Section 10 of the federal River and Harbors Act.
3. ***Florida Department of Environmental Protection (DEP)*** – Has oversight of Florida's wetlands programs and acts as the permitting authority for the state's NPDES Stormwater Program and some dewatering activities.
4. ***Water Management Districts*** – There are five water management districts in the state: Northwest Florida, Suwannee River, St. Johns River, Southwest Florida, and South Florida. These regional agencies implement the state's wetlands permitting program for most larger types of projects, as well as consumptive use/dewatering permits.
5. ***Counties/Cities/Community Development Districts/Other Special Districts*** – These governmental entities have a multitude of local ordinances that can be more restrictive than those of the federal, state, and regional governmental programs.



# Appendices

---

---

## Appendix A. Human Relations

The hardest part of an inspector's job is dealing with people. You will be working with contractors, developers, neighbors, and concerned citizens. All have rights as citizens and as human beings.

To deal effectively with people, you must be fair and consistent. You must follow the rules governing erosion and sediment control, and you must apply them fairly. Fairness means treating all people with courtesy and respect. If you show respect for the other person, that person is more likely to show respect for you. It is important to be as consistent as possible. If you apply the rules consistently to every situation, the people you deal with will know what to expect from you and your organization.

Perhaps the most challenging part of being an inspector is carrying out your responsibilities in a professional manner. Sometimes you may feel pressured not to cite deficiencies, but it is your job to make sure all rules are followed. The objective is to prevent accelerated erosion and offsite damage from sediment. To do this job well and be respected as a professional, you must maintain your integrity.

You will visit many construction sites, offices, and other agencies. For these visits, prepare a short introduction explaining who you are, what your job is, and why you are there. Give a business card to those you meet to help them remember your name and the role of your organization.

### Dealing with Angry or Difficult People

Individuals who have complaints frequently come to the inspector. Consequently, the inspector often has to handle heated confrontations.

When a person voices a complaint, you will not have time to prepare a response. Therefore, you must resolve the situation spontaneously. You can be prepared, however, by developing skills for dealing with conflict situations. The general guidelines in the following section will help in handling angry people.

#### *Key Steps*

A situation with an angry person should be handled in a manner that is satisfactory to the person, yourself, and the organization you represent. Your organization or company relies on you to handle these situations effectively. Use the steps listed below as a guide for developing your skills in dealing with angry people. You can tailor these skills to fit your own personality and style:

### **1. Maintain a friendly and professional manner.**

You are likely to be the first person an angry individual confronts. Be careful not to argue because it will only make the person become defensive and even more difficult. Show an interest in the person's problem and express your desire to solve it. Do not let the person's anger arouse your desire to retaliate. Handling a conflict situation diplomatically is your professional responsibility and can be rewarding. Do not take what the individual says personally.

Please note that some organizations may have policies against speaking to the general public. If this is the case, respectfully direct them to the appropriate person to lodge their complaint with.

### **2. Acknowledge that a difficult situation exists.**

Show that you take the complaint seriously. It is important that you help the person maintain self-esteem. The complaint must not be viewed as unimportant. The person would not be complaining if he or she did not consider the problem important.

Choose words and use a tone of voice that show sensitivity to the party's situation. The person wants to know that you understand the situation. An angry person does not want to hear (and probably is unable to hear) that he or she is wrong. Express empathy by responding to what the person says and feels. Expressing empathy does not mean you agree with the individual. It means simply that you recognize and respond to what the person is experiencing. If an apology is in order, apologize for the specific incident and no more.

### **3. Calm the individual by questioning and verifying.**

By asking questions you can verify your understanding of the situation and also demonstrate that you are willing to work with the person. This also helps the person to work with you. Ask questions to get specific information about the problem.

Never assume that you understand. Give the person responses to show that you understand the situation.

### **4. Involve the person in solving the problem.**

The next step is to get the person to cooperate in exploring alternate solutions. Show that you are interested in solving the problem. By discussing all alternatives and the consequences of each solution, you can keep the party focused on the problem and thereby avoid side issues. Ask the person to help you solve the problem. Request suggestions for solving the problem and offer your assistance to help correct the situation. Your knowledge of erosion and sediment control can guide the party to a reasonable solution that keeps the site in compliance with the permit. Explain the applicable permit requirements and the reasoning behind them. Often frustration and adversity are reduced when permit holders are made aware of the intent of the rules. Continue to ask questions in order to keep the person focused on solving the problem. If the individual is still angry, continue to empathize, showing that you understand the problem.

## **5. Handle the problem.**

Having explored the possible solutions, focus on the most feasible and satisfying solution. Be positive with the person. Explain what you are going to do in a way that the person understands. If he resists, go on to another alternative. Be as helpful as you can. Satisfying the person's desire for service and special attention can sometimes turn an opponent into an advocate. Decide on a follow-up action to ensure that the problem has been resolved satisfactorily.

### **Being the Bearer of Bad News**

There will be times when you will have to be the bearer of bad news. You may have to tell a person that you cannot solve a complaint to his or her satisfaction, and/or you may have to inform a responsible party of a deficiency. These situations can be very stressful for both you and the other person. The following section lists key steps that will help prepare you to deliver bad news.

#### *Key Steps*

##### **1. Present the situation.**

Explain the situation to the person with as few words as possible. When your discussion is concise, direct, and to the point, the person is spared the anxiety of wondering how bad the news is. Prepare the person for the negative information. It may be necessary to provide a short background explanation of the events leading up to the present situation. Provide reasons why the situation has occurred. You may be able to show that the person's actions were not responsible for the situation. Do not try to give the person good news first and then the bad news—this can appear patronizing. Do not make the bad news seem insignificant; it probably is significant to the person involved.

##### **2. Allow the person time to adjust.**

Most people need a little time to collect their thoughts and react emotionally to bad news. Allow the person some time but try not to leave long periods of silence.

Some people perceive silence as pressure to react and therefore may react inappropriately. Try discussing the positive aspects of the situation. The person may or may not hear you, but positive comments can help keep the conversation constructive and the outlook optimistic.

##### **3. Accept the person's reaction.**

Allow the person to express his or her feelings and opinions. It is normal to react emotionally to bad news. Allowing people to ventilate their emotions shows that you accept their feelings and helps to reduce the negative aspects of the situation. If the person does not offer a reaction, try talking briefly about how you have felt or would feel in a similar situation. Then ask for the person's reaction. Use this technique to stress that you are empathetic to the other person's dilemma. However, do not get caught up in discussing your own troubles.

#### **4. Demonstrate acceptance of the person's reaction.**

A person may react emotionally in many different ways and may not clearly express his or her feelings. By accepting their emotions, you reaffirm them as valuable and important. Most of us find it hard to talk about emotions in the workplace, and we have trouble accurately identifying the emotions of others. You must observe and listen carefully to determine if the person's true feelings are being expressed.

When receiving bad news, the person may feel a wide range of emotions, such as anger, dissatisfaction, embarrassment, or confusion. Respond to these emotions by remaining calm, expressing empathy, offering reassurance, or providing further explanation. Try to mentally identify or name the emotion that the person is feeling. Identifying the person's reaction allows you to accept the reaction for what it is—that is, not a personal affront to you. Understanding how the other party feels also helps you anticipate upcoming statements and remain in control of your own emotions.

People often react by blaming another person, a group, or the system. The person is simply reacting from his or her anger—try not to take it personally. Avoid being caught in answering questions that are really meant as statements. For instance, "Don't you think this is unfair?" really means "I think this is unfair." Restate the question as "I understand that you think this is unfair." Sometimes you may be able to use self-disclosure to diffuse the situation. In other words, state how you have felt in similar situations. Statements such as, "I know just how you feel," can be taken as patronizing. Rather, say, "I know how I've felt in situations like this."

#### **5. Restate positive points.**

Once the initial emotional reaction has passed, help the person put the situation into perspective. You can help the person see the situation more positively by expressing confidence in his or her ability to meet the challenge and by providing genuine praise for efforts put forth. Re-emphasize the basic facts about the situation and discuss any steps that can be taken to address the problem.

#### **6. Offer assistance.**

If appropriate, you can offer to assist the person in future actions or planning. Do not offer to do something that you are not authorized to do. Inform the person that it may be necessary to submit revised plans and/or seek professional help.

#### **7. Clearly express that deficiencies must be corrected.**

An emotionally upset person may not be able to fully understand the situation or may intentionally misunderstand the conversation. Be sure that the person understands the information you have provided and knows what is expected to correct or address the situation. Repeat the actions that must be taken by all parties, and the required time frames. Discuss the required action. If you cannot change the requirements or time frames, tell the person that you regret that you cannot change them.



A good way to ensure that the person understands the information you have discussed is to ask the person to repeat the details of your discussion in his or her own words. For example, "I want to be sure I haven't said something that might be misunderstood. Would you tell me, in your own words, your understanding of this discussion?"

**8. Allow for future contact and follow-up.**

Give the person a chance to contact you for further discussion. You may need to schedule a future meeting. You should always give the person your business card and phone numbers where you can be reached. Confirm, in writing, the conclusions reached so that all parties have a similar basis for their understanding of the situation.

## Appendix B. Estimating Quantities

### Stockpiles

Stockpiles can often be conveniently measured by calculating the volume of regular masses of similar outline and making plus or minus adjustments for differences. A pile of clean dry sand may have a conical shape, or be a ridge with a triangular cross-section, ending in half cones. Measurements should be taken to determine base size and height.

The area of the circular base of a cone is found approximately from the circumference by the formula:

$$\frac{\text{Area} = \text{Circumference}^2}{12.6}$$

and from half the diameter by:

$$\text{Area} = 3.14 \times \text{Radius}^2$$

The volume of a cone is the height times one-third the base area. The long part of the pile is figured by the formula:

$$\frac{\text{Volume} = \text{Height} \times \text{Width} \times \text{Length}}{2}$$

A long pile will have the volume of the center section, plus the volume of one cone, as each of the ends is a half cone.

### Excavated Pond

The volume of excavation required can be estimated with sufficient accuracy by the use of the prismatic formula:

$$V = \frac{(A + 4B + C)}{6} \times \frac{D}{27}$$

where:

V = Volume of excavation, in cubic yards.

A = Area of the excavation at the ground surface, in square feet.

B = Area of the excavation at the mid-depth point (1/2 D), in square feet.

C = Area of the excavation at the bottom of the pond, in square feet.

D = Average depth of the pond, in feet.

27 = Factor converting cubic feet to cubic yards.

## Appendix C. Sample Checklists

The sample checklists provided can serve as a basis for creating specific checklists tailored to the specific duties and conditions of each public or private use.

### General Information

Some or all of the following information should appear on all checklists:

- *Project name.*
- *Permit number.*
- *Property parcel number.*
- *Name of inspector/reviewer.*
- *Name of design professional.*
- *Weather; or date and amount of last rain event.*

## **WARNING !**

A checklist is an excellent tool for organizing yourself for an inspection or plan review. Like any other tool, a checklist can and will hurt you if not used properly! It is only a tool, not a substitute for the human mind. A checklist can lull you into a false sense of completeness and security. After using a checklist, ask yourself "Is there anything else, anything that is not covered in the checklist?" Periodically examine your checklists to make sure that they cover the issues you encounter and that they stay current with any changing regulations or other conditions.

## 1. Plan Review

Use the appropriate sections as applicable to the type of review you are doing.

### *Narrative*

- **Project description:** A brief description of the nature and purpose of the land-disturbing activity and the amount of grading involved.
- **Existing site conditions:** A description of the existing topography, vegetation, and drainage.
- **Adjacent areas:** A description of neighboring areas, such as streams, lakes, residential areas, and roads that might be affected by the land disturbance.
- **Soils:** A brief description of the soils on the site, including erodibility and particle size distribution.
- **Critical areas:** A description of areas within the developed site that have the potential for serious erosion or sediment problems.
- **Erosion and sediment control measures:** A description of the methods that will be used to control erosion and sediment on the site.
- **Permanent stabilization:** A brief description of how the site will be stabilized after construction is completed.
- **Maintenance:** A schedule of regular inspections and repairs of erosion and sediment control structures.

### *Site Plan or Map*

- **Vicinity map:** A map showing the project located within the larger region, including principal roads.
- **North arrow** (pointed in the correct direction).
- **Existing contours:** Existing elevation contours of the site at an interval sufficient to determine drainage patterns.
- **Preliminary and final contours:** Proposed changes in the existing elevation contours for each stage of grading.
- **Existing vegetation:** Locations of trees, shrubs, grass, and unique vegetation.
- **Soils:** Boundaries of the different soil types within the proposed development.

- **Critical areas:** Areas within or near the proposed development with the potential for serious erosion or sediment problems.
- **Existing and final drainage patterns:** A map showing the dividing lines and the direction of flow for the different drainage areas before and after development.
- **Limits of clearing and grading:** A line showing the area to be disturbed.
- **Erosion and sediment control measures:** Locations, names, and dimensions of the proposed temporary and permanent erosion and sediment control measures.
- **Stormwater management system:** Location of permanent storm drain inlets, pipes, outlets, and other permanent stormwater management facilities (swales, waterways, etc.); and sizes of pipes, channels, and structures.

### **Details**

- **Detailed drawings:** Enlarged, dimensional drawings of such key features as sediment basin risers, energy dissipators, and waterway cross-sections.
- **Seeding and mulching specifications:** Seeding dates, seeding, fertilizing, and mulching rates in pounds per acre (kg/ha), and application procedures.
- **Maintenance program:** Inspection schedule, spare materials needed, stockpile locations, and instructions for sediment removal and disposal and for the repair of damaged structures.

### **Calculations**

- **Calculations and assumptions:** Data for design storm used to size pipes and channels, and sediment basins and traps; design particle size for sediment traps and basins; estimated trap efficiencies; basin discharge rates; size and strength characteristics for filter fabric, wire mesh, fence posts, etc.; and other calculations necessary to support stormwater, erosion, and sediment control systems.

## **2. Preconstruction Conference**

A preconstruction conference is one of the most valuable ways to address and avoid potential erosion and sedimentation problems, as well as environmental impacts. It provides you with an opportunity to meet face-to-face with the responsible authority and the contractors. In this way,

you can establish the expectations for the project and start a good working relationship with the involved parties.

During the conference, keep the following suggestions in mind:

1. *Clarify the objectives of erosion and sediment control and inform all parties of the specific requirements for compliance in the project. Also, discuss the inspection procedures and schedule for major earth-moving activities.*
2. *Ask the responsible authority to designate a contact person for communicating compliance issues and concerns.*
3. *Be sure that all parties receive/view a copy of the approved erosion and sediment control plan.*
4. *Inform the responsible authority and contractors that the program is performance oriented and that the plan may need to be updated during the course of construction. Inform all parties about procedures for changing the plans.*
5. *Try to hold the conference onsite so the group can walk the site. Evaluate the plans to determine whether the measures are appropriate, are located properly, and can be maintained once installed.*
6. *Discuss the schedule for clearing and grading. Emphasize that sediment control measures should be installed before the actual grading begins, in order to capture sediment as it is generated. Be sure that the schedule allows for stabilizing surfaces with temporary and permanent measures between phases of grading and construction.*
7. *Discuss the maintenance requirements so that the responsible authority and contractors know who is responsible for inspecting, cleaning, and repairing the erosion and sediment control measures. Regular inspection and maintenance may need to be supplemented with extra work if a large storm is forecast, or if there are cleanup activities after a large storm, or even if there is a higher-than-normal amount of site activity.*
8. *Establish open communications at the preconstruction conference; this provides a good foundation for your relationship with the responsible authority during the project.*

**Verify the following:**

- **Permits:** Check that contractor/developer has all required permits, including, but not limited to, the following: federal, DEP, FDOT, water management

*district, local or municipal, building permit if required.*

- **Licenses:** *Get the name, license number, and type of license for all contractors involved in site development.*
- **Contacts:** *Get the name, phone number, and mailing address of the property owner and all contractors involved in site development.*
- **Special conditions:** *Check for special conditions attached to any permits. This could be one of the most crucial aspects of the permit.*

**Discuss the following:**

- **Plans and scope of work:** *Be sure that the contractor understands the plans and the tasks to be performed.*
- **Special conditions:** *Point out that any special conditions are as valid and enforceable as the permit itself; they are not optional. Make sure that everything is clearly understood. Write down any unresolved issues and follow up quickly.*
- **Erosion and sediment controls:** *Discuss the location, proper installation, and maintenance requirements of BMPs. Examine the erosion and sediment control details.*
- **Protection of buffers and natural areas:** *Discuss the methods used to protect these areas. Be sure that they will not be used for parking, portable toilets, material storage, waste disposal, or other unintended uses.*
- **Tree protection:** *Verify the location and type of protected trees that will remain. Discuss protection requirements and methods. Be sure that protected areas will not be used for parking, etc.*
- **Construction sequencing:** *The construction sequence will be enforced. Perimeter controls, sediment traps and basins, and necessary conveyances will be installed and stabilized **before** the rest of the site is cleared.*
- **Performance-oriented regulations:** *Be sure that the contractor understands that the site will be out of compliance if erosion and sediment controls fail, even if everything has been done according to plan. In that event additional measures will be required.*
- **Plan changes:** *Construction will not be allowed that differs from the plans. Major changes to the erosion and sediment control plan, or any changes to the site development plan, will require reapproval. Minor changes to the*

*erosion and sediment control plan must be approved by the inspector.*

- ***Routine inspections:*** *Advise the contractor that you will be monitoring the site for the proper installation and diligent maintenance of BMPs.*
- ***Final inspection:*** *A final inspection will be performed when all permitted improvements have been completed. Inform the contractor about the documents which will be required at that time (i.e., Operating Permit, Post-Construction Certification, As-Built Drawings, etc.).*
- ***Inspect the site:*** *Walk or drive around the site with the contractor. Point out any potential problems onsite or offsite. Tell the contractor what you will be looking for on your next inspections.*
- ***Affirmation:*** *Provide the owner/contractor with a copy of your checklist and make sure again that everything has been discussed and clearly understood. Note any clarifications, agreements, and unresolved issues. Sign and date all copies and have them do the same.*



### 3. Routine Inspection Troubleshooting Guide

Table B-1 provides troubleshooting guidance for some common problems.

**Table B-1. Control measures, problems to look for, and possible remedies**

Control Measure	Problems to Look For	Possible Remedies
Vegetation	Rills or gullies forming	Check for top-of-slope diversion and install if needed.
Vegetation	Bare soil patches	Fill rills and regrade gullied slopes; revegetate.
Vegetation	Sediment at toe of slope	Remove sediments; revegetate using site-appropriate methods.
Berms	Gully on slope below dike breach; wheel track or low spot in dike	Add soil to breaches or low spots and compact.
Berms	Loose soil	Compact loose soil.
Berms	Erosion of berm face	Line upslope face with riprap; or revegetate using site-appropriate methods.
Swales	Gully on slope below swale	Repair breaches.
Swales	Wheel track, low point (water ponded in swale)	Build up low areas with compacted soil or sandbags; or rebuild swales with a positive slope.
Swales	Sediment or debris in channel	Remove obstructions.
Swales	Erosion of unlined channel surface	Mulch and install anchored sod or erosion control blanket; or line swale with riprap; or install check dams; or realign swale on gentler gradient; or divert some or all stormwater to more stable facility.
Swales	Erosion of channel lining	Install larger riprap; or reseed, mulch, and anchor with netting; or install check dams; or pave swale.
Pipe slope drain or flume	Blocked inlet or outlet	Remove sediment and debris.
Pipe slope drain or flume	Runoff bypassing inlet	Enlarge headwall or flare out entrance section.
Pipe slope drain or flume	Erosion at outlet	Enlarge riprap apron and use larger riprap; or convey runoff to a more stable outlet.
Grassed waterways	Bare areas	Revegetate with anchored sod or erosion control blanket; divert flow during establishment period.
Grassed waterways	Channel capacity reduced by tall growth	Mow grass.
Riprap-lined waterway	Scour beneath stones	Install proper geotextile or graded bedding. Make sure edges of geotextile are buried.
Riprap-lined waterway	Dislodged stones	Replace with larger stones.
Outlet protection	Erosion below outlet	Enlarge riprap apron; or line receiving channel below outlet; or convey runoff directly to a more stable outlet. Make sure discharge point is on level or nearly level grade.
Outlet protection	Outlet scour	Install proper geotextile or graded bedding beneath riprap apron.
Outlet protection	Dislodged stones	Replace with larger stones.

Control Measure	Problems to Look For	Possible Remedies
Sediment traps and basins	Sediment level near outlet elevation	In traps, remove sediment if less than 1 foot (30 cm) below outlet elevation; in basins, remove sediments if less than 2 feet (60 cm) below top of riser.
Sediment traps and basins	Obstructed outlet	Remove debris from trash rack.
Sediment traps and basins	Basin not dewatering between storms	Clear holes. Clean or replace sediment-choked gravel surrounding dewatering hole or subsurface drain.
Sediment traps and basins	Damaged embankments	Rebuild and compact damaged areas.
Sediment traps and basins	Spillway erosion	Line spillway with rock, geotextile, or pavement.
Sediment traps and basins	Outlet erosion	Make sure outlet is flush with ground and on level grade. Install, extend, or repair riprap apron as required; or convey discharge directly to a more stable outlet.
Sediment traps and basins	Riser flotation	Anchor riser in concrete footing.
Sediment traps and basins	Excessive discharge to and from basin or trap	Check runoff patterns for consistency with plans. Reroute part of volume to another basin or enlarge the basin.
Sediment traps and basins	Sediment storage zone fills too quickly	Increase size of basin; or stabilize more of the contributing area.
Silt fence	Undercutting of fence	Entrench wire mesh and fabric to proper depth, backfill, and compact.
Silt fence	Fence collapsing	Check post size and spacing, gauge of wire mesh and fabric strength. Check drainage area, slope length, and gradient behind barrier. Correct any substandard condition.
Silt fence	Torn fabric	Replace with continuous piece of fabric from post to post; attach with proper staples.
Silt fence	Runoff escaping around fence	Extend fence.
Silt fence	Sediment level near top of fence	Remove sediment when level reaches half of fence height.
Check dam	Sediment accumulation	Remove sediment after each storm.
Check dam	Flow escaping around sides of check dam	Build up ends of dam and provide low center area for spillway.
Check dam	Displacement of sandbags, stones, or wattles	Check drainage areas and peak flows. Reinforce dam with larger stones, etc.; or divert part of flow to another outlet.
Inlet protection	Flooding around or below inlet	Remove accumulated sediment; or convert sediment barrier to an excavated sediment trap; or reroute runoff to a more suitable area.
Inlet protection	Undercutting of wattles or silt fence, wattle displacement, torn fabric, etc.	See remedies for wattles and silt fences.

## 4. Final Inspection

### *General*

- *Are all Final Inspection documents in order (As-Built drawings, Compliance Report, Postconstruction Certification, Operating Permit, etc.)?*
- *Are all applicable easements recorded with the Clerk of the Court?*
- *Are the roads, buildings, parking, sidewalks, etc., as shown on plans?*
- *Is there any significant change in the amount of impervious area?*
- *Did natural or undisturbed areas remain that way?*
- *Are all utilities installed (not necessarily hooked up)?*
- *Are there any outstanding violations or fees?*
- *Is there any offsite disturbance or adverse impact from this project?*

### *Stormwater Facilities*

- *Is the stormwater management facility (pond or ponds) where it should be?*
- *If the facility is underground, is there access for maintenance?*
- *Is the facility the size and depth it should be?*
- *Are the slopes as shown on plans and stabilized?*
- *If applicable, is the stormwater facility fenced?*
- *Are the control structures as shown and clean?*
- *Is the filter system as shown and clean?*
- *Are energy dissipaters as shown and stabilized?*
- *Is the pond bottom free of sediments?*
- *Are aquatic plantings installed as shown and in good condition?*
- *Does the facility meet minimum performance standards as permitted (treatment and volume recovery)?*

### ***Stormwater Conveyance***

- *Is the conveyance system as shown, free of debris, and stabilized?*
- *Are all inlets as shown and clean?*
- *Are roof drains as shown?*
- *Is all water onsite directed to ponds, except accessways?*

### ***Landscaping/Natural Areas***

- *Are natural buffers existing and undisturbed?*
- *If buffers were to be augmented, have they been?*
- *Is uncomplimentary land use buffer, if applicable, as shown and planted or fenced to meet permit/code requirements?*
- *Can buffer areas be accessed for maintenance?*
- *Are landscape islands in parking areas as shown? Is perimeter landscaping as shown?*
- *Are all landscape areas protected by curbing, wheel stops, or other physical barrier?*
- *Do all landscape areas have access to irrigation, if needed?*
- *Do all plantings conform to the approved landscape schedule?*
- *Are all seeded areas firmly established, and have they reached 70 % density over all unpaved areas of the site?*
- *Is all sod firmly established and properly anchored?*
- *Are pollution abatement swales installed and stabilized per the plans, including behind finished home sites?*
- *If long-term landscape maintenance is required, is there a plan in place?*

## **Appendix D. The Erosion and Sediment Control Plan**

An erosion and sediment control plan can be used to fulfill some or all of the requirements of a SWPPP, as long as it meets the minimum requirements of the current CGP rule. An erosion and sediment control plan is the document that describes who and what will control erosion and when, where, and how this will be done. The plan is the common link of communication between the designer, the contractor, and the inspector. A thorough understanding of the plan is essential for proper implementation.

### **Elements of the Erosion and Sediment Control Plan**

The erosion and sediment control plan submitted to the approving agency with the project application should contain all the pertinent information for review and implementation. The following five elements, discussed in the sections below, should be described in the plan and are required in many communities:

1. *The stormwater team.*
2. *Contractors and subcontractors.*
3. *Narrative description of site activities, including a map/site plan.*
4. *Construction details, specifications, and notes.*
5. *Calculations.*

#### **1. The Stormwater Team**

The stormwater team (name or position of individuals) responsible for implementing the SWPPP, including the qualified inspector, should be identified. List each individual's responsibilities in developing or implementing the SWPPP should be described.

#### **2. Contractors and Subcontractors**

The contractors and subcontractors who will be carrying out construction activities at the site should be identified, as well as the areas on the site where they will be working. All listed contractors and subcontractors must sign certifications.

#### **3. Narrative Description of Site Activities, Including a Map/Site Plan**

The narrative briefly describes the overall strategy for erosion and sediment control. It should summarize for the plan reviewer and the project superintendent the aspects of the project that are important for erosion control and should include the following:

- a. A brief description of the proposed land-disturbing activities, existing site

- conditions, and adjacent areas (such as creeks and buildings) that might be affected by the land disturbance.
- b. A description of critical areas on the site, including those with the potential for serious erosion problems such as severe grades, highly erodible soils, and areas near wetlands or waterbodies.
  - c. A construction schedule that includes the date grading will begin and the expected date of stabilization.
  - d. A brief description of the measures that will be used to minimize erosion and control sediment onsite, when they will be installed, and where they will be located.
  - e. A maintenance program, including frequency of inspection, provisions for the repair of damaged structures, and routine maintenance of erosion and sediment control practices.

### ***The Map/Site Plan***

The map/site plan is the key item in an erosion and sediment control plan. It should show the following:

- a. The existing and final elevation contours at an interval and scale sufficient to distinguish runoff patterns before and after disturbance.
- b. Critical areas in or near the project area, such as streams, lakes, wetlands, highly erodible soils, public streets, and residences.
- c. Existing vegetation.
- d. The limits of clearing and grading.
- e. The locations and names of erosion and sediment control measures, with dimensions.

It is strongly recommended that standard symbols be used on the map to denote erosion and sediment control measures. The use of these symbols speeds up plan review and makes it easier for site superintendents and inspectors to understand plans quickly. The symbols were designed to be both pictorially representative of the control measures and easy to draw.

### **4. Construction Details, Specifications, and Notes**

Construction details, often contained in large-scale, detailed drawings, provide key dimensions and spatial information that will not fit on the map. Other important information should also be provided, such as seeding and mulching specifications; equivalent opening size (EOS) and strength requirements for filter fabric; specifications for wire mesh, fence posts, and staples; procedures for control measures; and maintenance instructions.

## 5. Calculations

Include the calculations used to size the control measures, particularly the data for the design storm (recurrence interval, duration and magnitude, and peak intensity for the time of concentration) and the design assumptions for sediment basins and traps (design particle size, trap efficiency, discharge rate, and dewatering time). Also include calculations to support the sizing of storm drain systems when an engineered design is necessary.

### **Implementing the Erosion and Sediment Control Plan**

There are seven principal steps, as follows, to installing an erosion and sediment control plan, primarily from the standpoint of the job superintendent:

1. *Study of the plan and site to organize implementation.*
2. *Preconstruction conference between the job superintendent and inspector.*
3. *Site preparation.*
4. *Inspection and maintenance of erosion control measures.*
5. *Grading and utilities installation.*
6. *Building construction.*
7. *Permanent stabilization.*

#### **1. Study of the Plan and the Site to Organize Implementation**

The job superintendent must be thoroughly familiar with both the erosion and sediment control plan and the construction site. Note all of the critical areas indicated in the plan and then actually identify their location and extent on the ground. These should include stream channels and associated floodplain areas, drainageways, outlets into streams, points where land-disturbing activities are adjacent to or must cross streams and drainageways, steep slopes and highly erodible soils, and runoff entering the site from adjacent areas. Note what practices are specified to protect these areas. Also, be aware of critical areas not specifically treated in the plan and discuss these with the inspector at the preconstruction conference.

Next, determine the locations of all control measures and determine their "fit" on the land. Note any needed adjustments and plan to discuss these at the preconstruction conference.

Check the schedule for the installation of erosion and sediment control practices, the schedule for all earth-disturbing activities, and the relationship between the sequence and timing of BMP installation and the earth-disturbing activities. The timing and sequence of installation are important elements of an erosion and sediment control plan. The site must be ready for rain before the earth-disturbing activities are started. For this reason, certain practices must be in

place and ready to provide protection before other areas are exposed. The staging of major earth-disturbing activities to limit the size of bare area exposed at any time is another important element of the plan that should be noted.

## **2. Preconstruction Conference Between the Job Superintendent and Inspector**

The job superintendent should call for a preconstruction conference and site review with the erosion and sediment control inspector; the conference should be held on the construction site. The conference may also include the design professional, the owner, and inspectors from other agencies. The site review helps all parties meet their responsibilities.

All aspects of the plan should be discussed to ensure that the job superintendent and the inspector are in agreement in interpreting the plan, scheduling, procedures, and practices to be used. In particular, they should agree on the critical problem areas and on the perimeter practices specified to prevent damage to adjacent properties.

The location of all measures should be discussed. If a study of the plan indicates that adjustments in location are needed, these should be discussed with the permitting agency and the inspector. The inspector may authorize minor adjustments such as moving a diversion from a property line to a grading limit or shifting an outlet to match a natural depression in the land. Major adjustments require a formal revision of the plan and should be approved by the permitting agency.

The sequence for the installation of practices and earth-disturbing activities should also be discussed. The guidelines for erosion and sediment control planning require that sediment basins and other appropriate erosion and sediment control measures be installed prior to or as a first phase of land grading.

Other appropriate measures include construction entrances, diversion berms, interceptor berms, perimeter berms, gravel outlet structures, level spreaders, swales, protected outlets, and grade stabilization structures. The job superintendent and the inspector must be firm about the establishment of these practices before grading begins. **Appendix C** of this manual contains a sample preconstruction checklist.

## **3. Site Preparation**

One of the first tasks in preparing the site is to lay out all traffic circulation routes and storage areas. Route locations should be chosen to pose the least threat to the critical areas that have been identified. Well-vegetated areas should be damaged as little as possible. Soil stockpiles should be located a safe distance from waterways and streams.

Barriers may be required to keep traffic within the delineated areas or at least out of the critical areas. If needed, barriers should be installed before opening the site to general construction traffic. The workforce should be instructed about the location of critical areas and sediment control practices and the need to protect these areas from damage.



Required sediment-trapping measures should be installed. Note that compacting, seeding, and mulching are required to stabilize these measures. Next, waterways and outlets should be installed with the vegetation or lining material called for in the plan.

#### **4. Inspection and Maintenance of Erosion Control Measures**

Maintenance differs from the other activities in that it must begin as soon as the first measure is installed and must continue through all the succeeding activities until the permanent erosion control measures are established and functioning. The narrative part of the plan describes the features of a maintenance program. All structural measures should be checked at the close of each workday and particularly at the end of the work week. Also, they must be checked before and after each rainstorm of a quarter inch or more.

Diversion berms should be checked to see that they have not been breached by equipment. The condition of level spreader areas, waterways, and other outlets should also be checked. Traffic should be moving within the established access routes.

Channels should be checked for sediment deposits or other impeding material. Repairs should be made promptly when damage is discovered. When repairing swales or other channels, the new lining material should be at least as erosion resistant as the original material.

Vegetative measures and vegetative cover on structural BMPs require maintenance fertilizer and perhaps mowing. All sediment traps should be checked and cleaned out after each storm. Sediment basins should be cleaned out when the deposited material reaches the level designated in the plan or standards and specifications. **Appendix C** of this manual provides a sample maintenance checklist.

#### **5. Grading and Utilities Installation**

If the stockpiling of fill or topsoil is planned for use in grading, a preselected, relatively safe stockpile area should be used. To minimize erosion hazards, the slopes of the stockpile should be flattened at the end of each working period. The stockpile should be mulched and seeded as soon as it is completed.

Disturbed areas that can be brought to final grade at this stage during a satisfactory season for seeding should be seeded, sodded, or otherwise stabilized with the permanent material and techniques indicated in the plan. If they cannot be seeded, they should be stabilized with anchored mulch. Areas that are to remain at rough grade for more than seven days before permanent stabilization must be mulched and seeded to temporary cover immediately following rough grading.

Utilities such as storm sewers, sanitary sewers, electrical conduits, water mains, and gas mains are usually installed at this time. To minimize the amount of area disturbed, the work should be organized and the trenches sized to accommodate several utilities in one trench. The installation should be carefully coordinated to reduce the time that the trenches must stay open. Excavated

materials should be placed on the side of the trench away from streams and conveyances. If sediment-laden water must be pumped from utility trenches, it should be conveyed safely to a sediment trap or basin. As soon as possible, trenches should be filled, compacted, mulched, and seeded to temporary or permanent vegetation.

As soon as the storm sewers are installed, inlet sediment traps should be installed to prevent sediment from entering the system. If called for, storm drain outlet protection should be installed.

## **6. Building Construction**

The following two major hazards are common during building construction:

- 1. Additional equipment and workers bring added risks to areas that should be protected. Efforts to control traffic must be increased during this period. All types of traffic should be made to stay on the established travel routes.*
- 2. The excavating process usually results in large quantities of soil for disposal and stockpiling. Stockpiles should be located where they will not wash into drainageways or onto previously stabilized areas. The slopes on these areas should be flattened, and they should be protected by anchored mulch and temporary seeding. Excavations should be backfilled as soon as possible, and appropriate surface protection should be provided.*

Runoff from rooftops should be directed to stabilized areas upon the completion of the structure. Whenever possible, runoff should be treated or infiltrated in swales or retention facilities. Rooftop runoff should never be tied in to sanitary sewers.

## **7. Permanent Stabilization**

This process need not and should not be delayed until the entire development is completed. Erosion damage repair costs and regrading costs can be significantly reduced if smaller areas are stabilized with permanent vegetation as soon as they are ready.

Most sediment basins, berms, sediment traps, and other control structures should be removed, regraded, mulched, and seeded before a construction project is completed. However, the inspector should be consulted before removing erosion and sediment control BMPs and they should not be removed until the surrounding area is stabilized, and they are no longer needed.

In some cases, sediment basins, diversions, and swales will remain as part of the permanent runoff management system. In such cases, the sediment basins should be cleaned out to provide the required capacity and stabilized with suitable permanent vegetation. Diversions and swales should be checked, repaired if needed, and left in good condition. The inspector will check on the final condition of measures that are to be retained.

When final grading is completed, all bare areas should be stabilized with permanent vegetation.

## **Appendix E. Construction Generic Permit**

**DEP Document No. 62-621.300(4)(a)**

State of Florida

Department of Environmental Protection

### **NPDES Generic Permit**

For

Stormwater Discharge from Large and Small Construction Activities

Effective Date: 02/2015

This permit is issued under the provisions of Section 403.0885, Florida Statutes, and applicable rules of the Florida Administrative Code pursuant to the Department's federally-approved National Pollutant Discharge Elimination System (NPDES) stormwater regulatory program. Stormwater discharge associated with large construction activity, as defined at 40 C.F.R. Part 122.26(b)(14)(x) and herein, is regulated pursuant to Section 402(p)(2) of the federal Clean Water Act (CWA). Stormwater discharge associated with small construction activity, as defined at 40 C.F.R. 122.26(b)(15) and herein, is regulated pursuant to Section 402(p)(6) of the CWA. This permit constitutes authorization to discharge stormwater associated with large and small construction activities to surface waters of the State, including through a Municipal Separate Storm Sewer System (MS4). Until this permit is terminated, modified or revoked, permittees that have properly obtained coverage under this permit are authorized to discharge to surface waters of the State, including through an MS4, in accordance with the terms and conditions of this permit.

## TABLE OF CONTENTS

<b>PART 1: PERMIT COVERAGE.....</b>	<b>1</b>
<b>PART 2: YOUR APPLICATION = NOTICE OF INTENT (NOI) .....</b>	<b>3</b>
<b>PART 3: DISCHARGES .....</b>	<b>5</b>
<b>PART 4: STORMWATER POLLUTION PREVENTION PLAN (SWPPP)..</b>	<b>7</b>
<b>PART 5: BEST MANAGEMENT PRACTICES (BMPs) .....</b>	<b>10</b>
<b>PART 6: INSPECTIONS AND RECORDS .....</b>	<b>12</b>
<b>PART 7: COMPLETION = NOTICE OF TERMINATION (NOT).....</b>	<b>16</b>
<b>PART 8: DEFINITIONS AND ACRONYMS .....</b>	<b>17-21</b>
<b>PART 9: STANDARD PERMIT CONDITIONS .....</b>	<b>22</b>

### HOW TO USE THIS DOCUMENT

This generic permit is written in plain English. It sets forth a series of questions along with the answers that are designed to make it easier for you to understand who needs a permit, how you get permit coverage, and what you must do to meet the permit's requirements. Underlined blue words are terms that are defined in Part 8, Definitions and Acronyms. If you click on these words, you will be taken to the part of the document where the term is defined. To get back to your original part of the document, you must install the "BACK" button for Word.

To install the "BACK" button and "FORWARD" button, complete these steps:

1. Click the Microsoft office button or FILE in the top left corner of your Word window.
2. Click on "Word Options" at the bottom of the menu.
3. Click on "Customize" from the left pane.
4. In "Choose commands from" drop-down menu, select "All Commands".
5. From the list of commands find "Back" and click "Add"
6. Similarly, find "Forward" and click "Add"

## This Document Constitutes Your Permit

<b>PART 1: PERMIT COVERAGE</b>	
	<b><i>Do I need this permit for my project?</i></b>

### **1.1 When is this permit required?**

An NPDES Stormwater construction generic permit is required for any [construction activities](#) that:

- 1.1.1 Disturb one or more acres of land or disturb less than one acre of land but are part of a [common plan of development or sale](#); and
- 1.1.2 Discharge stormwater to surface waters of the state or to surface waters of the State through a municipal separate storm sewer system ([MS4](#)).

You, the Responsible Authority, shall apply either for an individual permit or for coverage under this National Pollutant Discharge Elimination System ([NPDES](#)) Construction Generic Permit (CGP). The Responsible Authority of a construction activity is ultimately responsible for obtaining and complying with this permit.

### **1.2 What does the CGP allow me to do?**

The CGP allows you to discharge surface stormwater associated with [large](#) or small construction activity to waters of the State, either directly or through an MS4.

### **1.3 If I obtain the CGP, do I still need an Environmental Resource Permit (ERP) or other permit?**

Obtaining coverage under the CGP does not relieve you of the requirement to obtain an Environmental Resource Permit ([ERP](#)). If an ERP is required then contact the Department, the appropriate [water management district](#), or a delegated local program for more information. You may also need to obtain other required permits from federal, state, or local governments.

### **1.4 Do I need this permit if I am one of several contractors working at a common site?**

- 1.4.1 If you are a contractor or subcontractor acting under the direction of an operator or other entity who has received coverage under the CGP for your construction activities, you do not have to obtain your own coverage under this permit, but must be named on the operator's SWPPP and separately sign the SWPPP certification (see [Part 4.5](#)).

- 1.4.2 If you are not named in the SWPPP or are not acting under the direction of the responsible authority who has obtained permit coverage, you must obtain your own permit.

## **1.5 Are there any limitations of coverage?**

The following stormwater discharges from construction sites are not authorized by this permit. This permit specifically does not allow you to do any of the following:

- 1.5.1 Cause or contribute to a violation of surface water quality standards;
- 1.5.2 Discharges stormwater mixed with non-stormwater, except as otherwise provided in [Part 3](#) of this CGP;
- 1.5.3 Discharge stormwater that originates from the site after construction activities have been completed and the site has undergone final stabilization;
- 1.5.4 Discharges that are mixed with sources of non-stormwater;
- 1.5.5 Discharges stormwater associated with construction activities that are covered under an existing generic or individual permit. Such discharges may be authorized under this permit after the existing generic permit or individual permit term of coverage expires or is terminated, provided the existing permit did not establish numeric limitations for such discharges; or
- 1.5.6 Discharges stormwater associated with construction activity that the Department has determined to be or may reasonably be expected to be causing or contributing to a violation of surface water quality standards.

<p><b>PART 2: YOUR APPLICATION = NOTICE OF INTENT (NOI)</b></p>	
	<p><i><b>How do I apply for coverage under this permit?</b></i></p>

**2.1 How do I apply for coverage under this permit?**

You must:

- 2.1.1 Submit a "Notice of Intent to Use Generic Permit for Stormwater Discharge from Large and Small Construction Activities, DEP Form 62-621.300(4)(b)," also known as Notice of Intent or NOI, to the Department; and
- 2.1.2 Submit the required permit application fee. For Large construction sites disturbing 5 or more acres, the required fee is \$400. For Small construction sites disturbing 1- 4.99 acres, the required fee is \$250. Land disturbances less than one acre of land but are part of a [common plan of development or sale](#) must apply for coverage.

**2.2 What must I do before applying for the CGP?**

Before you submit your NOI, you must develop and be ready to implement a Stormwater Pollution Prevention Plan ([SWPPP](#)). The minimum requirements for a SWPPP are listed in [Part 4](#).

**2.3 Where can I obtain and file my NOI and permit fee?**

- 2.3.1 You can submit your NOI and payment electronically through the Department business portal at <http://www.fldepportal.com/go/>. Permit fees must be paid by check, credit card or debit card.
- 2.3.2 Alternatively, you can submit a paper copy of your NOI by downloading the form at: [http://www.dep.state.fl.us/water/stormwater/npdes/permits\\_forms.htm](http://www.dep.state.fl.us/water/stormwater/npdes/permits_forms.htm) and submitting it, along with your permit fee, to the [Notices Center](#).

**2.4 Who can sign the NOI?**

The [responsible authority](#) must sign the NOI unless the responsible authority designates a [duly authorized representative](#) who may sign on the responsible authority's behalf as prescribed in Part 8.9.

## **2.5 When is the NOI due?**

- 2.5.1 For a new project, you must submit a complete NOI and permit fee at least 2 calendar days before commencement of construction by clearing, grading, excavating, demolition, or other [construction activities](#) disturbing soil. An application is complete upon submittal of all requested information, submittal of the required permit fee, and correction of any error or omission for which the applicant was timely notified or when the time for such notification has expired.
- 2.5.2 For a project continuing beyond the five-year term of any existing CGP permit coverage, you must submit the complete NOI and permit fee at least 2 calendar days before your current permit expires to renew your coverage.
- 2.5.3 For a project where the operator changes, the new operator must submit the complete NOI and permit fee at least 2 calendar days before assuming control of the project.

## **2.6 What happens after I submit my NOI and Permit fee?**

Your NOI will be determined complete or incomplete:

- 2.6.1 If incomplete, the Department will contact you to request additional information or request payment of the required permit fee.
- 2.6.2 If complete, the Department will send you an acknowledgment letter that will identify the term of your permit coverage.
- 2.6.3 You must post a copy of the NOI or, post a copy of the acknowledgment letter at the construction site in a prominent place for public viewing, such as alongside a building permit.
- 2.6.4 If your project discharges stormwater to an MS4, you must send a copy of the NOI or the acknowledgement letter within 7 calendar days of receipt to the operator of the MS4.

## **2.7 What is the term of my permit coverage?**

- 2.7.1 The term of your permit coverage begins 2 calendar days after the Department determines your submittal complete, and lasts 5 years or until you terminate your coverage under the permit.



<b>PART 3:DISCHARGES</b>	
	<b><i>What discharges are allowed under this permit?</i></b>

**3.1 What discharges are allowed under this permit?**

With limited exceptions, the CGP only allows stormwater discharges associated with construction activities and dewatering operations described in Part 3.4. The exceptions are listed below (see Parts 3.2 and 3.4).

**3.2 What non-stormwater discharges does the CGP allow?**

You can discharge the following types of non-stormwater discharges, if they are listed in your SWPPP and your SWPPP includes appropriate pollution prevention procedures as to not cause or contribute to a violation of water quality standards.

- 3.2.1 Discharges from firefighting activities.
- 3.2.2 Fire hydrant flushings.
- 3.2.3 Waters without detergents used to spray off loose solids from vehicles.
- 3.2.4 Waters used to control dust.
- 3.2.5 Potable water sources such as waterline flushings.
- 3.2.6 Landscape irrigation water and drainage.
- 3.2.7 Routine external building washdown provided no detergents are used.
- 3.2.8 Pavement washwaters that do not contain detergents, leaks, spills of toxic or hazardous materials.
- 3.2.9 Air conditioning condensate.
- 3.2.10 Spring water.
- 3.2.11 Foundation or footing drain flows that are not contaminated with process material such as solvents.
- 3.2.12 Noncontaminated ground water associated with dewatering activities as described in Part 3.4.

**3.3 What non-stormwater discharges are prohibited by the CGP?**

The following non-stormwater discharges are prohibited by the CGP:

- 3.3.1 Wastewater from concrete washout.
- 3.3.2 Wastewater from washout or cleanout of stucco, paint, form release oils, curing compounds, and other construction materials.
- 3.3.3 Fuels, oils, or other pollutants from vehicle and equipment operation and maintenance.
- 3.3.4 Soaps, detergents, solvents, or other cleaners.
- 3.3.5 Hazardous substances or oil resulting from an on-site spill.

- 3.3.6 Solid materials, including building materials.
- 3.3.7 Any other non-stormwater discharge not specifically allowed by Part 3.2 of the CGP.

**3.4 Can I discharge water from [groundwater dewatering operations](#) under this permit?**

- 3.4.1 The CGP authorizes the discharge of [uncontaminated](#) ground water.
- 3.4.2 If your project site is uncontaminated, in accordance with Part 3.4.3 below, you are authorized under the CGP to discharge uncontaminated groundwater resulting from construction-related dewatering operations. To obtain this authorization, you must complete Part VI of the NOI. The operator is responsible for ensuring the groundwater is uncontaminated.
- 3.4.3 An uncontaminated site must meet the following conditions:  
The property is either (a) not identified as a [contaminated site](#) and there is no identified contaminated site within 500 feet, or (b) it is identified as a contaminated site, but DEP documentation confirms that the contamination has been remediated or the pollutants of concern from the contaminated site are not present in groundwater at the project site at concentrations equal to or greater than the surface water criteria in Rule 62-302.530, F.A.C.
- 3.4.4 Documentation that the project site is uncontaminated must be kept at the project site with the SWPPP.
- 3.4.5 Appropriate dewatering [BMPs](#) shall be implemented to ensure that discharges from dewatering operations do not cause or contribute to violations of water quality standards. (See [Part 5.8.](#)) The BMPs must be included in the Dewatering Section of the SWPPP.
- 3.4.6 Discharges from dewatering operations must:
  - a) Not include visible floating solids or foam;
  - b) When feasible, discharge onto vegetated upland areas of the site where the water can infiltrate. As an alternative, the water can be discharged into the permitted stormwater system serving the project site.

**Note:** Backwash water should be managed such that it is not discharged directly to waters of the State. Backwash water may be hauled away for proper disposal or returned to the beginning of the treatment process.

**3.5 What if I suspect the discharge from dewatering operations are from a contaminated site?**

- 3.5.1 If a discharge from dewatering operations causes or contributes to a water quality violation, the permittee shall contact the Department. This permit only authorizes the discharge of uncontaminated groundwater. A site that does not meet the conditions of 3.4.3 may qualify for coverage under Rule 62-621.300(1), F.A.C., or under an individual wastewater permit on the appropriate form listed in Rule 62-620.910, F.A.C.
- 3.5.2 Coverage under this permit may be suspended, revoked and reissued, or terminated in accordance with Rule 62-620.345, F.A.C., if the Department determines that there has been a violation of any of the terms or conditions of the permit, there has been a violation of state water quality standards or the permittee has submitted false, incomplete or inaccurate data or information.

<p><b>PART 4: STORMWATER POLLUTION PREVENTION PLAN (SWPPP)</b></p>	
	<p><i><b>How do I develop my stormwater pollution prevention plan?</b></i></p>

**4.1 What is the purpose of the [SWPPP](#)?**

The purpose of the SWPPP is to document how you will comply with the requirements of this permit.

**4.2 How do I develop my (SWPPP)?**

You must prepare a SWPPP following standard industry practices. You can find training, samples, guidance, templates, and links to other resources to help you develop your SWPPP on our web page:

<http://www.dep.state.fl.us/water/stormwater/npdes/construction3.htm>.

**4.3 When must I start following my SWPPP?**

You must develop your SWPPP before you submit your NOI. You must start following your SWPPP when you receive coverage under this permit. If your SWPPP requires perimeter controls, they must be installed before the commencement of your construction activities.

**4.4 Where do I keep my SWPPP and other records and how long do I have to retain them?**

4.4.1 Keep all of these records at the construction site, or at an appropriate alternative location as specified in the NOI.

4.4.2 You must maintain a site log notebook or computer file folder that contains copies of the NOI, the acknowledgement letter granting coverage, your SWPPP, all your inspections reports, records, and all notifications from the Department concerning your site.

4.4.3 Keep all of these records for three years from the date that the site has reached final stabilization and the Notice of Termination (NOT) is submitted.

**4.5 How often must I update my SWPPP?**

You must keep your SWPPP current. You must sign and date any changes to the SWPPP and keep them as attachments to the original plan. Whenever any of the following events occur, you have seven calendar days to update your SWPPP:

- 4.5.1 There is a change in design, construction, operation, or maintenance that has a significant effect on the discharge from your project.
- 4.5.2 There is a new discharge point or outfall.
- 4.5.3 There is a change in the location of a discharge point or outfall.
- 4.5.4 An inspection (see [Part 6](#)) reveals that BMPs are ineffective at eliminating or minimizing pollutants in the stormwater discharged from the site.
- 4.5.5 There is a new [operator](#), contractor, or subcontractor implementing any portion of the SWPPP. If a new operator is taking over a portion of the project site, you must update your SWPPP to note the area that is no longer covered by your CGP and inform the new operator in writing that you are no longer covering construction activities in that area. This documentation must be kept as part of your SWPPP. (See [Part 1.4](#)).
- 4.5.6 A release containing a hazardous substance in an amount equal to or greater than a reportable quantity occurs during a 24-hour period. (See [Part 9.2](#) for important information about releases of hazardous substances in excess of reportable quantities.)

**4.6 Who needs to sign the SWPPP?**

All contractors and subcontractors identified in the SWPPP must sign a copy of the following certification statement before conducting any construction activities at the site. The certifications must have the name and title of the person signing the certification; the name, address, and telephone number of the contracting firm; and the signature date.

*"I certify under penalty of law that I understand, and shall comply with, the terms and conditions of the State of Florida Generic Permit for Stormwater Discharge from Large and Small Construction Activities and this Stormwater Pollution Prevention Plan."*

**4.7 What needs to be in the SWPPP?**

Table 4.7-1 lists the items that must be included in your plan. The SWPPP must clearly identify the contractor(s) or subcontractor(s) that will implement each item.

**Table 4.7.1 Contents of the SWPPP**

Stormwater Team	Identify the personnel (by name or position) that are part of the stormwater team responsible for implementing the SWPPP, including the <a href="#">qualified inspector</a> . List their individual responsibilities in developing or implementing the SWPPP.
Contractors /Subcontractors	List all the contractors or subcontractors who will be conducting construction activities at the site, and identify the areas of the site in which they will be working. All listed contractors and subcontractors must sign the certification.
Site/Construction Activities Description	<ul style="list-style-type: none"> <li>• Describe the nature of the <a href="#">construction activity</a>.</li> <li>• Describe the intended sequence and time table of major activities that will disturb soils.</li> <li>• Include the scheduled starting and ending date for each major activity such as land clearing, grubbing, grading, cut and fill, dewatering operations, installation of erosion and sediment controls, installation of stormwater management systems, paving, <a href="#">final</a> or <a href="#">temporary stabilization</a> of exposed soil, and removal of construction equipment and vehicles.</li> <li>• Estimate the total area of the site and the total area that is expected to be disturbed by excavation, grading, or other construction activity.</li> </ul>

	<ul style="list-style-type: none"> <li>• Include existing data on soil types and the quality of any existing discharge from the site.</li> <li>• For each proposed discharge point provide the following: <ul style="list-style-type: none"> <li>➢ Latitude and Longitude</li> <li>➢ Drainage Area</li> <li>➢ Surface Waters or MS4</li> </ul> </li> <li>• Estimate the amount of land that will be cleared during the construction activity for each drainage area.</li> </ul>
Site Map	<p>Include a site map showing all of the following:</p> <ul style="list-style-type: none"> <li>• Boundaries of the property.</li> <li>• Entrance/Exit Points</li> <li>• Locations where construction activities will occur.</li> <li>• Locations where dewatering operation will occur.</li> <li>• Drainage patterns and approximate slopes and elevations anticipated after major grading activities.</li> <li>• Areas of soil disturbance.</li> <li>• Areas which will not be disturbed.</li> <li>• Location of major <a href="#">structural</a> and <a href="#">nonstructural controls</a>.</li> <li>• Location of areas where <a href="#">stabilization</a> practices are expected to occur.</li> <li>• Location of <a href="#">surface waters</a> and wetlands.</li> <li>• Location where stormwater is proposed to be discharged during construction to a surface water or MS4.</li> </ul>
Non-stormwater Discharges	List all non-stormwater discharges covered under this permit and the pollution prevention procedures that will be implemented. (See <a href="#">Part 3.3</a> )
Dewatering Controls (Applicable)	Include a description of the <a href="#">BMPs</a> that will be used to ensure that discharges of noncontaminated ground water from <a href="#">dewatering operations</a> do not cause or contribute to violations of state water quality standards.
BMPs	Describe the <a href="#">BMPs</a> that will be implemented for each major activity and the timing during the construction process that they will be implemented. (See <a href="#">Part 5</a> )
Permanent stormwater management controls	Describe the stormwater management controls or <a href="#">BMPs</a> (e.g., stormwater detention or retention systems, vegetated swales, or velocity dissipation devices at discharge points) that will be installed during the construction process to control pollutants in stormwater discharges. (See <a href="#">Part 5.7</a> )
Inspections	Must be at least once every seven calendar days and within 24-hours of the end of a storm event that is 0.50 inches or greater (even if it rains on the weekend or a holiday) (See <a href="#">Part 6</a> )
Maintenance	Describe the maintenance activities and schedules that will be followed to keep <a href="#">BMPs</a> in good and effective operating condition.
Signed Certifications	Include all the signed contractors and subcontractors certifications in the SWPPP.

<p><b>PART 5: BEST MANAGEMENT PRACTICES (BMPs)</b></p>	
	<p><b><i>What BMPs apply to my project?</i></b></p>

**5.1 What BMPs am I required to use on my project?**

Construction activities must not cause or contribute to a water quality violation or offsite sedimentation. You are encouraged to phase your construction activities to avoid potential water quality violations. BMPs must be installed before the commencement of your construction activities.

All BMPs must be consistent with the guidelines contained in the State of Florida Erosion and Sediment Control Designer and Reviewer Manual, FDOT and FDEP (2013) <http://www.stormwater.ucf.edu/publications/2013RevisedDesignerManual.pdf>, or from <http://www.flrules.org/Gateway/reference.asp?No=Ref-04227>.

You are required to comply with the following:

- 5.1.1 You must implement pollution prevention control BMPs described in Part 5.2.
- 5.1.2 You must implement erosion and sediment control BMPs as described in Part 5.3.
- 5.1.3 You must stabilize soils in accordance with Part 5.4.
- 5.1.4 You must implement structural controls as described in Part 5.5.
- 5.1.5 You must implement dewatering BMPs as described in Part 5.8.
- 5.1.6 If you disturb more than 10 acres at any one time, you must comply with the requirements of Part 5.6 relating to sediment basins.
- 5.1.7 All BMPs must be maintained until [Final Stabilization](#) has been achieved for the portions of the site served by the BMPs. BMPs include pollution prevention controls, erosion and sediment controls, stabilization practices, and structural controls. All BMPs must be described in your SWPPP.
- 5.1.8 Dewatering BMPs must be maintained throughout the duration of dewatering operations.
- 5.1.9 Temporary perimeter controls must be removed after final stabilization.

**5.2 What pollution prevention control BMPs must be implemented?**

You must, at a minimum, install, implement, and maintain pollution prevention control BMPs that accomplish all of the following:

- 5.2.1 Minimize the discharge of pollutants from equipment and vehicle washing, wheel wash water, and other wash waters that are covered under this permit so as to not cause a violation of water quality standards or offsite sedimentation.

- 5.2.2 Minimize the exposure of building materials, building products, construction wastes, trash, landscape materials, fertilizers, pesticides, herbicides, detergents, sanitary waste, toxic substances, and other materials present on the site to rain and to stormwater that may run onto or across your site so as to not cause or contribute to a violation of water quality standards.
- 5.2.3 Minimize the discharge of pollutants from spills and leaks. Your SWPPP must include and you must implement chemical spill and leak prevention and response procedures.

### **5.3 What erosion and sediment control BMPs apply?**

You must, at a minimum, install, implement, and maintain appropriate erosion and sediment controls that accomplish all of the following so as to not cause or contribute to a violation of water quality standards and minimize offsite sedimentation:

- 5.3.1 Control stormwater volume and velocity within the site to minimize soil erosion and offsite sedimentation.
- 5.3.2 Control stormwater peak discharge rates and volume to minimize erosion at discharge outfalls and to minimize downstream channel and stream bank erosion.
- 5.3.3 Minimize the amount of soil exposed during the construction activity.
- 5.3.4 Minimize the disturbance of steep slopes.
- 5.3.5 Minimize sediment discharges from the site.
- 5.3.6 Minimize off-site vehicle tracking of sediments onto paved surfaces and the generation of dust so as to prevent the potential for water quality violations and offsite sedimentation. If sediment escapes the construction site, remove off-site accumulations of sediment at a frequency sufficient to minimize off-site impacts.
- 5.3.7 In selecting your sediment and erosion controls, you must consider factors such as the amount, frequency, intensity, and duration of precipitation; the characteristics of the resulting stormwater; and the site's soil characteristics, including the range of soil particle sizes expected to be present on the site.

### **5.4 Do I have to use Stabilization Measures?**

You must initiate stabilization measures within 7 calendar days after construction activities have temporarily or permanently ceased for any portion of the site.

Stabilization measures include:

- Temporary seeding.
- Permanent seeding.
- Mulching.
- Geotextiles.
- Sod stabilization.
- Vegetative buffer strips.
- Protection of trees.
- Preservation of mature vegetation.
- Other appropriate measures.

- 5.4.1 You must include in your SWPPP, and update when necessary, the dates when major grading activities occur, when construction activities temporarily or permanently cease on a portion of the site, and when stabilization measures are initiated.
- 5.4.2 You must achieve Final Stabilization prior to filing a Notice of Termination in accordance with [Part 7.1](#) or the expiration of coverage under this, or a subsequent, generic permit.

## 5.5 Do I have to use Structural Practices?

You must use controls to accomplish the following:

- 5.5.1 As necessary to prevent violations of water quality or offsite sedimentation, you must divert flows from exposed soils, store flows, retain sediment on site, or otherwise limit runoff and the discharge of pollutants from exposed areas of the site.
- 5.5.2 Structural practices to prevent violations of water quality or offsite sedimentation, which may include the following: silt fences, earth dikes, diversions, swales, sediment traps, check dams, subsurface drains, pipe slope drains, level spreaders, storm drain inlet protection, rock outlet protection, reinforced soil retaining systems, gabions, coagulating agents, and temporary or permanent sediment basins.
- 5.5.3 Silt fences or equivalent structural controls are required for all side slope and down slope boundaries of the construction area.
- 5.5.4 Structural best management practices must be placed on upland soils unless a State of Florida [environmental resource permit](#) issued pursuant to Chapter 373, [F.S.](#), or applicable regulations of the DEP or WMD otherwise authorize.

## 5.6 What requirements apply to sediment basins?

If you have 10 or more disturbed acres on your site, the following design requirements shall be met:

- For drainage basins with 10 or more disturbed acres at one time, a temporary (or permanent) sediment or wet detention basin providing 3,600 cubic feet of storage per acre drained must be provided until final stabilization of the site. The 3,600 cubic feet of storage area per acre drained does not apply to flows from off-site areas and flows from on-site areas that are either undisturbed or have undergone final stabilization where such flows are diverted around both the disturbed area and the sediment basin.
  - For drainage basins with 10 or more disturbed acres at one time and where a temporary sediment basin providing 3,600 cubic feet of storage per acre drained is not attainable, a combination of smaller sediment basins, sediment traps, wet detention systems, or other best management practices must be used.
- 5.6.1 For drainage basins of less than 10 disturbed acres, sediment basins and sediment traps are recommended but not required.
  - 5.6.2 Areas that will be used for permanent stormwater infiltration treatment (e.g., stormwater retention basins) should not be used for temporary sediment basins unless appropriate measures are taken to assure removal of accumulated fine sediments, to avoid excessive compaction of soils by construction machinery or equipment, and to assure that the design infiltration capacity is met.



## **5.7 What requirements apply to permanent stormwater management controls?**

Your SWPPP must include a description of stormwater management controls or BMPs (e.g., stormwater detention or retention systems, vegetated swales, or velocity dissipation devices at discharge points) that will be installed during the construction process to control pollutants in stormwater discharges that will occur during construction and after construction operations have been completed.

Under this CGP, you are only responsible for the installation and maintenance of stormwater management controls until the construction activities have been completed and the site has undergone final stabilization. However, all stormwater management systems and BMPs must be operated and maintained in perpetuity after final stabilization in accordance with requirements set forth in the State of Florida [environmental resource permit](#) issued under Part IV, Chapter 373, F.S.

## **5.8 What Dewatering BMPs can I use?**

The operator shall develop and implement site specific control measures or BMPs to minimize or eliminate pollutant discharges resulting from dewatering operations to surface waters of the state. Appropriate BMPs shall have been developed and implemented upon commencement of the discharge. The most common BMPs for treating dewatering discharges include sediment traps and basins, weir and dewatering tanks, filters, and chemical treatment. These technologies and approaches provide a number of options to achieve sediment removal. The sizes of the particle that make up the sediments are a key consideration in selecting sediment control options.

<b>PART 6:INSPECTIONS</b>	
	<b><i>How should I inspect my project?</i></b>

**6.1 When must I inspect my site? By whom?**

Your site must be inspected at least once every seven calendar days and within 24 hours of the end of a [storm event](#) that is 0.50 inches or greater (even if it rains on the weekend or a holiday). Your site must be inspected by a [qualified inspector](#) that you must provide.

**6.2 What must your inspection cover?**

Your qualified inspector must:

- 6.2.1 Inspect all stormwater discharges from the site to ensure BMPs are not causing or contributing to violations of water quality standards or resulting in offsite sedimentation. <http://www.dep.state.fl.us/water/wqssp/classes.htm>
- 6.2.2 Inspect the BMPs identified in the SWPPP to ensure that they are installed, maintained, and operating correctly and effectively.
- 6.2.3 Inspect all areas used for storage of materials that are exposed to rainfall and runoff to ensure all BMPs are being used and maintained properly.
- 6.2.4 Inspect all locations where vehicles enter or exit the site for evidence of offsite sediment tracking and inform operator of all actions needing to be taken to remove sediments on the road and prevent it in the future.
- 6.2.5 Inspect all distributed areas and discharge points for signs of visible erosion and sedimentation.

**6.3 What information must be included in the inspection report?**

The report must contain all of the following:

- 6.3.1 Scope of the inspection.
- 6.3.2 Name(s) and qualifications of personnel making the inspection.
- 6.3.3 Date(s) of the inspection.
- 6.3.4 Rainfall data.
- 6.3.5 Major observations relating to the implementation of the SWPPP.
- 6.3.6 Corrective actions taken since last inspection in accordance with Part 6.4.
- 6.3.7 Any incidents of non-compliance. (Where an inspection does not identify any incidents of non-compliance, the report must certify that the facility is in compliance with the SWPPP and the CGP.)
- 6.3.8 Signature of the qualified inspector that prepared the report. (See [Part 9.1](#), below.)
- 6.3.9 Signature of a [responsible authority](#). (See [Part 9.1](#), below.)

**6.4 If the inspection identifies needed corrective actions, when must they be accomplished?**

Based on the results of the inspection, all corrective actions needed to assure proper

operation of all controls identified in your SWPPP or to ensure that the requirements of the permit are met must be done in a timely manner, but in no case later than 7 calendar days following the inspection or identification of the issue. If needed, you must revise your SWPPP and modify your controls in a timely manner, but in no case later than 7 calendar days following the inspection or identification of the issue. (See [Part 4.4](#))

## **6.5 Can I temporarily suspend the weekly/0.5 inch inspections?**

- 6.5.1 Once you have achieved final stabilization, you may suspend inspections.
- 6.5.2 You may reduce the frequency of inspections to once per month on your site if you:
  - 6.5.2.1 Have achieved temporary stabilization that is successful at stabilizing the site for the duration of your suspended construction activities; and
  - 6.5.2.2 Have your SWPPP updated as to why you are suspending construction activities at your site and have met the conditions of 6.5.1. The SWPPP must include:
    - a. The status and type of stabilization implemented,
    - b. The date the activities were suspended, and
    - c. The anticipated date activities will resume.
- 6.5.3 If construction activity resumes in this portion of the site at a later date, the inspection frequency immediately returns to the frequency required by this permit under Part 6.1. You are at all times responsible for ensuring that your temporary stabilization methods are in compliance with permit conditions.
- 6.5.4 If at any time after you suspend construction activities you determine the site will not resume activities during the term of your permit coverage, you must achieve Final Stabilization and file a Notice of Termination. During that intermediate period of time all terms of this permit will apply.

<p><b>PART 7: COMPLETION = NOTICE OF TERMINATION (NOT)</b></p>	
	<p><i><b>What should I do when my project is complete?</b></i></p>

**7.1 What must I do when my project is complete or I no longer need the permit coverage?**

Within 14 calendar days after your site has achieved [final stabilization](#) and all discharges authorized by this permit are eliminated or are authorized under a separate NPDES permit, you must submit a completed Notice of Termination ([NOT](#)) form.

7.1.1 All dewatering discharges authorized by this permit have ceased.

7.1.2 All construction activity discharges authorized by this permit have ceased.

Elimination of [stormwater discharges associated with construction activity](#) means that all disturbed soils at the site have been final stabilized, that temporary erosion and sediment control measures have been removed or will be removed at an appropriate time, and that all stormwater discharges associated with construction activity from the site that are authorized by the CGP have been eliminated.

**7.2 Can I transfer the CGP following a sale or transfer of project operation?**

Coverage under the CGP is not transferable. The new owner/operator will need to complete a SWPPP and submit a new NOI and processing fee. You need to end the current permit coverage by submitting a [Notice of Termination \(NOT\)](#) within 14 calendar days of relinquishing control of the project to a new owner/operator. It is the responsibility of the new owner/operator to obtain coverage before the NOT is submitted.

**7.3 How do I submit my NOT?**

7.3.1 You can submit the form electronically: To file your NOT online go to:  
<http://www.fldepportal.com/go/>

7.3.2 Alternatively you can submit a NOT by email to the [Notices Center](#): To download the NOT go to:  
[http://www.dep.state.fl.us/water/stormwater/npdes/permits\\_forms.htm](http://www.dep.state.fl.us/water/stormwater/npdes/permits_forms.htm)

For additional assistance please contact the Notice Center at: (866) 336-6312 (toll-free).

**7.4 Who can sign the NOT?**

The [responsible authority](#) must sign the NOI unless the responsible authority designates a [duly authorized representative](#) who may sign on the responsible authority's behalf.

**7.5 What happens after I submit my NOT?**

The Department will send you an acknowledgment letter by email. If your project discharged stormwater to a permitted MS4, you must send a copy of the NOT or the acknowledgement letter within 7 calendar days of receipt to the operator of the MS4.

<p><b>PART 8: DEFINITIONS AND ACRONYMS</b></p>	
	<p><i>What definitions and acronyms do I need to know?</i></p>

**DEFINITIONS**

**8.1 "Best Management Practices" or "BMPs"**

Schedules of activities, prohibitions of practices, maintenance procedures, and other management practices to prevent or reduce the pollution of surface waters. BMPs also include treatment requirements, operating procedures, and practices to control site runoff, spillage or leaks, sludge or waste disposal, or drainage from raw material storage. BMPs also include sediment and erosion controls, stabilization measures, and pollution prevention controls as described in: State of Florida Erosion and Sediment Control Designer and Reviewer Manual, FDOT and FDEP (2013) <http://www.stormwater.ucf.edu/publications/2013RevisedDesignerManual.pdf>, or from <http://www.flrules.org/Gateway/reference.asp?No=Ref-04227>.

**8.2 "Construction Activity"**

The act or process of developing or improving land, including demolition and renovation activity, which involves the disturbance of soils not limited to, clearing, grading, and excavation.

**8.3 "Contaminated Site"**

Any site that contains or did contain pollutants of concern in the groundwater that exceed the surface water criteria in 62-302.530, F.A.C.

**8.4 "Commencement of Construction"**

Means the initial disturbance of soil associated with clearing, grading, or excavating activities or other construction activities.

**8.5 "Common Plan of Development or Sale"**

A single plan of development or sale for a site where one or more separate and distinct construction activities are occurring on one or more schedules by one or more contractors. This may include:

- Phased projects and projects with multiple lots, even if the separate phases or lots will be constructed under separate contract or by separate owners (e.g., a development where lots are sold to separate builders).
- A development plan that may be phased over multiple years, but is still under a consistent plan for long-term development.
- Projects in a contiguous area that may be unrelated but still under the same contract, such as construction of a building extension and a new parking lot at the same facility.
- Linear projects such as roads, pipelines, or utilities.

**8.6 "Department" or "DEP"**

The Florida Department of Environmental Protection.

**8.7 "Dewatering activities"**

For the purposes of this generic permit means temporarily lowering the ground water level, whether confined or unconfined, by mechanical pumping to allow for construction and excavation activities at the construction site covered by this generic permit.

**8.8 "Discharge Point" or "Outfall"**

For the purposes of this permit, the location where collected and/or concentrated stormwater flows are discharged from the construction site.

**8.9 "Duly Authorized Representative"**

A duly authorized representative is a person who has been designated by the responsible authority to sign documents relating to this permit on the responsible authority's behalf. A responsible authority may authorize a duly authorized representative by submitting to the [Notices Center](#), by email or in writing an authorization that names either an individual or a position having overall responsibility for the operation of the your project, such as the project engineer, project superintendent, a position of equivalent responsibility, or an individual or position having overall responsibility for implementing the CGP at the site.

If an authorization is no longer valid because a different individual or position has overall responsibility for the operation of your project, a new authorization satisfying the above requirements must be submitted to the Notices Center prior to or together with any reports, information, or applications to be signed by an authorized representative.

**8.10 "Environmental Resource Permit" or "ERP"**

The permit issued under Part IV, Chapter 373, F.S., by the Department, a [WMD](#), or delegated local program that ensures that the stormwater flood control, stormwater treatment, and wetland protection requirements are met.

**8.11 "Final Stabilization"**

All soil disturbing activities at the site have been completed, and that a uniform (e.g., evenly distributed, without large bare areas) perennial vegetative cover with a density of at least 70% for all unpaved areas and areas not covered by permanent structures has been established or equivalent permanent stabilization measures (e.g., geotextiles) have been employed.

**8.12 "Groundwater"**

Means water beneath the surface of the ground within a zone of saturation, whether or not flowing through known and definite channels.

**8.13 "Large Construction Activity"**

Construction activity that results in the disturbance of five or more acres of total land area. Large construction activity also includes the disturbance of less than five acres of total land area that is part of a larger common plan of development or sale that will cumulatively disturb five acres or more.

**8.14 "Municipal Separate Storm Sewer System" or "MS4"**

An MS4 as defined in Chapter 62-624.200, F.A.C. (for more information)  
<http://www.dep.state.fl.us/legal/Rules/shared/62-624.pdf>

**8.15 "Nonstructural Controls"**

Practices that are specifically intended to reduce the amount of pollution getting into stormwater or surface waters. Nonstructural controls are generally implemented to address the problem at the source. They do not require any structural changes to the facility. Examples of nonstructural control practices include pollution prevention BMPs, good housekeeping practices, and preventative maintenance programs.

**8.16 "Notice of Intent" or "NOI"**

Notice of Intent to be covered by this permit.

**8.17 "Notice of Termination" or "NOT"**

Notice of Termination to cease coverage under this permit.

**8.18 "NPDES"**

The Department's federally-approved National Pollutant Discharge Elimination System program authorized by Section 403.0885, F.S.

**8.19 "NPDES Notices Center"**

The place to which you submit your NOI, NOT, or other information related to the process of obtaining, implementing, or terminating coverage under the NPDES Program. The email address is: [NPDES-stormwater@dep.state.fl.us](mailto:NPDES-stormwater@dep.state.fl.us)

The mailing address is: NPDES Stormwater Notices Center, MS #3585  
Florida Department of Environmental Protection  
2600 Blair Stone Road  
Tallahassee, Florida 32399-2400

The phone number is: (866) 336-6312 (toll-free)

**8.20 "Operator"**

The person, firm, contractor, public organization, or other legal entity that owns or operates the construction activity and that has authority to control those activities at the project necessary to ensure compliance with the terms and conditions of this permit.

**8.21 "Qualified Inspector"**

A person that:

1. Has successfully completed the DEP Stormwater, Erosion, and Sedimentation Control Inspector Training Program and received a certificate of completion.
2. Has successfully completed an equivalent formal training program;
3. Is qualified by other training or practical experience in the field of stormwater pollution prevention and erosion and sedimentation control.

#### **8.22 "Responsible Authority"**

Per Rule 62-620.305, F.A.C., a responsible authority means:

1. For a corporation, a responsible corporate officer as described in Rule 62-620.305, F.A.C.
2. For a partnership or sole proprietorship, a general partner or the proprietor, respectively.
3. For a municipality, state, federal or other public facility, a principal executive officer or elected official.

#### **8.23 "Small Construction Activity"**

Construction activity resulting in the disturbance of equal to or greater than one acre and less than five acres of total land area. Small construction activity also includes the disturbance of less than one acre of total land area that is part of a larger common plan of development or sale that will cumulatively disturb equal to or greater than one acre and less than five acres.

#### **8.24 "Stabilization"**

The use of vegetative and/or non-vegetative cover BMPs to prevent erosion and sediment loss in areas exposed through the construction process.

#### **8.25 "Storm Event"**

A rainfall event that results in a measurable amount of rain. A storm event is defined to be a separate event when there is at least four hours of no rain between periods of rainfall.

#### **8.26 "Stormwater"**

The flow of water which results from, and which occurs immediately following, a rainfall event.

#### **8.27 "Stormwater discharge associated with construction activity"**

The discharge of stormwater from large or small construction activities, including areas where soil disturbing activities, construction materials handling or storage, equipment storage or maintenance are located.

#### **8.28 "Structural Controls"**

Curbs, dikes, berms, swales, diversions, retention systems, detention systems or other structures which capture and treat stormwater to reduce pollutants in stormwater discharges.

#### **8.29 "SWPPP"**

The Stormwater Pollution Prevention Plan - A site-specific, written document that, among other things: (1) identifies potential sources of stormwater pollution at the construction site; (2) describes stormwater control measures to reduce or eliminate pollutants in stormwater discharges from the construction site; and (3) identifies procedures the operator will implement to comply with the terms and conditions of this general permit.



**8.30 "Surface Waters of the State"**

Those surface waters, including wetlands that are described in section [403.031](#), F.S.

**8.31 "Temporary Stabilization"**

A condition where exposed soils or disturbed areas are provided a temporary vegetative and/or non-vegetative protective cover to prevent erosion and sediment loss. Temporary stabilization may include temporary seeding, geotextiles, mulches, and other techniques to reduce or eliminate erosion until either final stabilization can be achieved or until further construction activities take place to re-disturb this area.

**8.32 "Uncontaminated"**

A discharge that does not cause or contribute to an exceedance of applicable water quality standards.

**8.33 "Water Management District" or "WMD"**

The Northwest Florida Water Management District, the Suwannee River Water Management District, the St. Johns River Water Management District, the Southwest Florida Water Management District or the South Florida Water Management District.

**OTHER ACRONYMS**

**BMP** Best Management Practice

**C.F.R.** Code of Federal Regulations

**CGP** Construction Generic Permit

**ERP** Environmental Resource Permit

**F.A.C.** Florida Administrative Code

**FDEP** Florida Department of Environmental Protection

**F.S.** Florida Statutes

**MS4** Municipal separate storm sewer system

**NOI** Notice of Intent

**NOT** Notice of Termination

**NPDES** National Pollutant Discharge Elimination System

**SWPPP** Stormwater Pollution Prevention Plan

<b>PART 9: STANDARD PERMIT CONDITIONS</b>	
	<b><i>What are the other terms of this permit?</i></b>

Any permit noncompliance constitutes a violation of Section 403.161, F. S. and is grounds for enforcement action; for permit coverage termination, or revocation; or for denial of permit coverage renewal.

For unauthorized releases or spills of treated or untreated wastewater reported that are in excess of 1,000 gallons per incident, or where information indicates that public health or the environment will be endangered, the operator must notify the State Warning Point (800-320-0519 or 850-413-9911) as soon as practical but no later than 24 hours from the time the permittee becomes aware of the discharge.

All of the general conditions listed in Rule 62-621.250, F.A.C., are adopted herein by reference.

**9.1 What are the signatory requirements for the CGP?**

- 9.1.1 All NOI, NOT, SWPPP, reports, certifications, or information either submitted to the Department or the operator of an MS4, or that this permit requires you to maintain, must be signed by the [responsible authority](#) unless you designate a duly authorized representative by submitting to the [Notices Center](#), in writing or by email, an authorization that names either an individual or a position having overall responsibility for the operation of the your project, such as the project engineer, project superintendent, a position of equivalent responsibility, or an individual or position having overall responsibility for implementing the CGP at the site.
- 9.1.2 If an authorization is no longer valid because a different individual or position has overall responsibility for the operation of your project, a new authorization satisfying the above requirements must be submitted to the Notices Center prior to or together with any reports, information, or applications to be signed by an authorized representative.
- 9.1.3 Inspection reports prepared pursuant to [Part 6.4](#) must be signed by the qualified inspector that prepared them as well as by a responsible authority.
- 9.1.4 Any person signing documents under this permit, except contractor or subcontractor certifications under [Part 4.5](#), must make the following certification: "I certify under penalty of law that this document and all attachments were prepared under my direction or supervision in accordance with a system designed to assure that qualified personnel properly gathered and evaluated the information submitted. Based on my inquiry of the person or persons who manage the system, or those persons directly responsible for gathering the information, the information submitted is, to the best of my knowledge and belief, true, accurate, and complete. I am aware that there are significant penalties for submitting false information, including the possibility of fine and imprisonment for knowing violations."

**9.2 What should I do upon a release of hazardous substances exceeding reporting quantities?**

The discharge of hazardous substances or oil in the stormwater discharge(s) from a facility or activity must be prevented or minimized in accordance with the applicable stormwater pollution prevention plan for the facility or activity. This permit does not relieve the operator of the reporting requirements of [40 C.F.R. part 117](#) and [40 C.F.R. part 302](#). Where a release containing a hazardous substance in an amount equal to or in excess of a reporting quantity established under either 40 C.F.R. 117 or 40 C.F.R. 302, occurs during a 24 hour period:

- 9.2.1 The operator must notify the State Warning Point (800-320-0519 or 850-413-9911) as soon as he or she has knowledge of the discharge.
- 9.2.2 The operator must submit, within 14 calendar days of knowledge of the release, a written description of: the release (including the type and estimate of the amount of material released), the date that such release occurred, the circumstances leading to the release, and remedial steps to be taken, to the Florida Department of Environmental Protection, NPDES Stormwater Section, Mail Station 3585, 2600 Blair Stone Road, Tallahassee, Florida 32399-2400 or by email at [NPDES-stormwater@dep.state.fl.us](mailto:NPDES-stormwater@dep.state.fl.us)
- 9.2.3 The SWPPP required under [Part 4](#) must be modified within seven calendar days of knowledge of the release to: provide a description of the release, the circumstances leading to the release, and the date of the release. In addition, the plan must be reviewed to identify measures to prevent the recurrence of such releases and to respond to such releases, and the plan must be modified where appropriate.

# Program Evaluation

## Florida Stormwater, Erosion, and Sedimentation Control Inspector's Course and Qualification Certificate Program

Instructor(s): \_\_\_\_\_

Class Location: \_\_\_\_\_

Date(s): \_\_\_\_\_

**Please rate each of the following areas by checking the appropriate number:  
1 for Poor, 2 for Fair, 3 for Good, and 4 for Great. Comment where appropriate.**

### **Announcement and Registration**

1    2    3    4

Comment –

### **The Manual**

1    2    3    4

Comment –

### **The Multi-Media (PowerPoint) Presentation**

1    2    3    4

Comment –

### **The Review Workbook**

1    2    3    4

Comment –

## Program Evaluation – Page 2

### Florida Stormwater, Erosion, and Sedimentation Control Inspector’s Course and Qualification Certificate Program

Please rate each of the following areas by checking the appropriate number:  
1 for Poor, 2 for Fair, 3 for Good, and 4 for Great. Comment where appropriate.

#### The Facility

1    2    3    4

Comment –

#### The Instructor(s)

1    2    3    4

Comment –

#### The Overall Program

1    2    3    4

Comment –

#### The Future

Please answer “Yes” or “No” for these survey questions:

Would you like to have an advanced level or TIER III covering the “Designer and Reviewer Manual?”  
Yes / No (Circle One)

Have a Florida Stormwater & Erosion Control Annual Conference that could cover advanced applications of erosion and sediment control, new technologies, and/or regulatory issues?  
Yes / No (Circle One)

Please provide any comments about or ideas you may have to improve our program –